

**MOUNTING PAD LAYOUT**

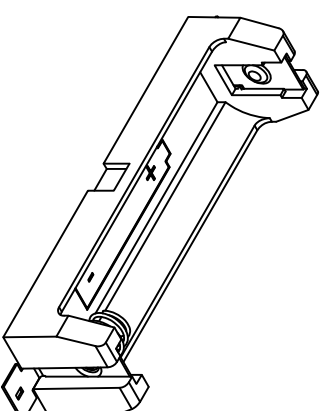
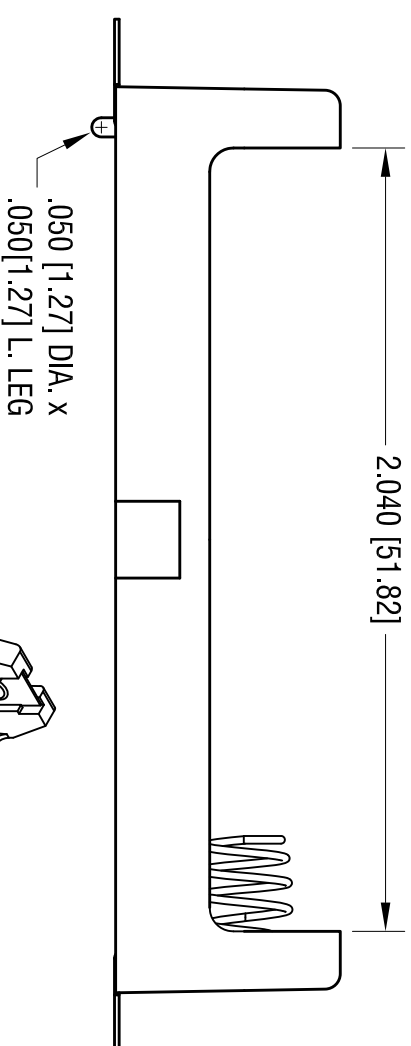
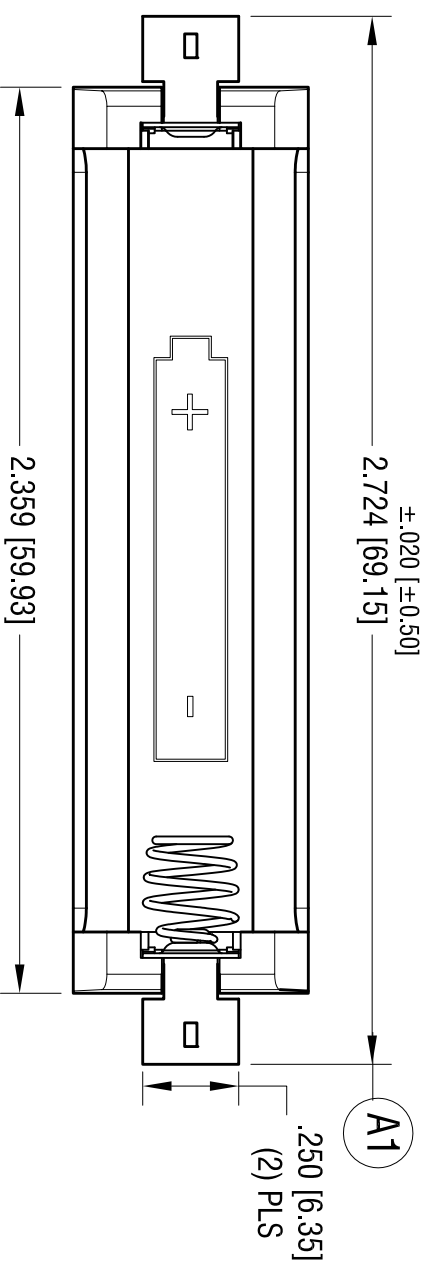
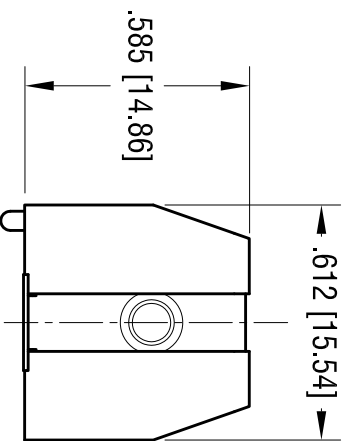
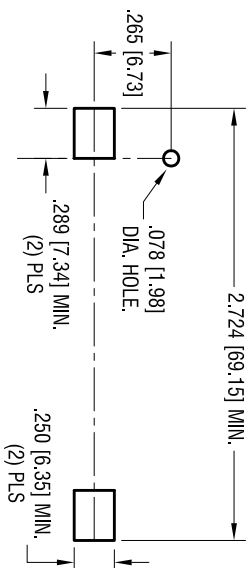

**NOTE:**

**1. BASE:**

MAT'L: HEAT RESISTANCE NYLON  
STANVL 46 OR EQUIVALENT

**2. CONTACTS:**

MAT'L: BASE-.012 [0.30] THK STAINLESS STEEL  
SPRING-.020 [0.50] DIA. MUSIC WIRE  
FINISH: GOLD FLASH, OVER NICKEL PLATE.

| DATE     | DESCRIPTION              | REV. |
|----------|--------------------------|------|
| 10.24.19 | CHANGE AS PER ECN 19-080 | A    |
|          | (A1) WAS 2.711 ±.010     |      |

THIS DOCUMENT IS THE PROPERTY OF KEYSTONE ELECTRONICS CORP. AND SHALL NOT BE REPRODUCED, DISTRIBUTED OR USED AS A BASIS FOR MANUFACTURE WITHOUT PRIOR WRITTEN PERMISSION FROM KEYSTONE ELECTRONICS CORP.

|                                                                 |           |           |      |
|-----------------------------------------------------------------|-----------|-----------|------|
| <b>KEYSTONE ELECTRONICS CORP.</b>                               |           |           |      |
| www.keystec.com • ASTORIA, N.Y. 11105-2017 • Tel (718) 956-8900 |           |           |      |
| PART NAME                                                       |           |           |      |
| SMT SINGLE BATTERY HOLDER, AA                                   |           |           |      |
| MATERIAL                                                        |           |           |      |
| AS NOTED                                                        |           |           |      |
| FINISH                                                          |           |           |      |
| AS NOTED                                                        |           |           |      |
| TOLERANCES                                                      | INCH      | [MM]      | CODE |
| DECIMAL                                                         | ± .010    | [± 0.25 ] | C    |
| ANGULAR                                                         | ± 2.27.13 |           |      |
| UNLESS OTHERWISE SPECIFIED                                      |           |           |      |
| DRN BY                                                          | DATE      | DWG NO.   |      |
| NT                                                              | 6.12.14   | 1088      |      |
| App'D                                                           | SCALE     |           |      |
| RH                                                              | 2X        |           |      |