

ADP-BNCM-BNCF-T BNC Plug to BNC Jack Adapter

The ADP-BNCM-BNCF-T is a BNC plug to BNC T jack adapter. Operating from 0 Hz to 6.5 GHz, the ADP-BNCM-BNCF-T combines superior performance, compact size, and a convenient bayonet-style mating interface to provide a reliable, easy-to-use adapter. Additionally, all Linx BNC adapters meet RoHS lead free standards and are tested to meet requirements for corrosion resistance, vibration, mechanical and thermal shock.



Features

- 0 Hz to 6.5 GHz operation
- BNC plug (male pin) connection
 - Nickel plated zinc body
 - Gold plated brass center contact
- BNC T jack (female socket) connections
 - Nickel plated zinc body
 - Gold plated brass center contact

Applications

- Audio/Video
- Broadcasting
- Test Equipment
- Surveillance Systems
- Ethernet
- Industrial, Commercial, Enterprise

Table 1. Electrical Specifications

Parameter	Value	
Impedance	50 Ω	
Frequency Range	0 Hz to 6.5 GHz	
Contact Resistance	Center: ≤ 3.0 mΩ Outer: ≤ 2.0 mΩ	
Port-to-Port	Port 2 to Port 1	Port 2 to Port 3
Insertion Loss (dB max.)	5.0	5.2
VSWR (max.)	2.3	2.1

Ordering Information

Part Number	Description
ADP-BNCM-BNCF-T	BNC plug (male pin) to BNC T jack (female socket) adapter

Available from Linx Technologies and select distributors and representatives.

Product Dimensions

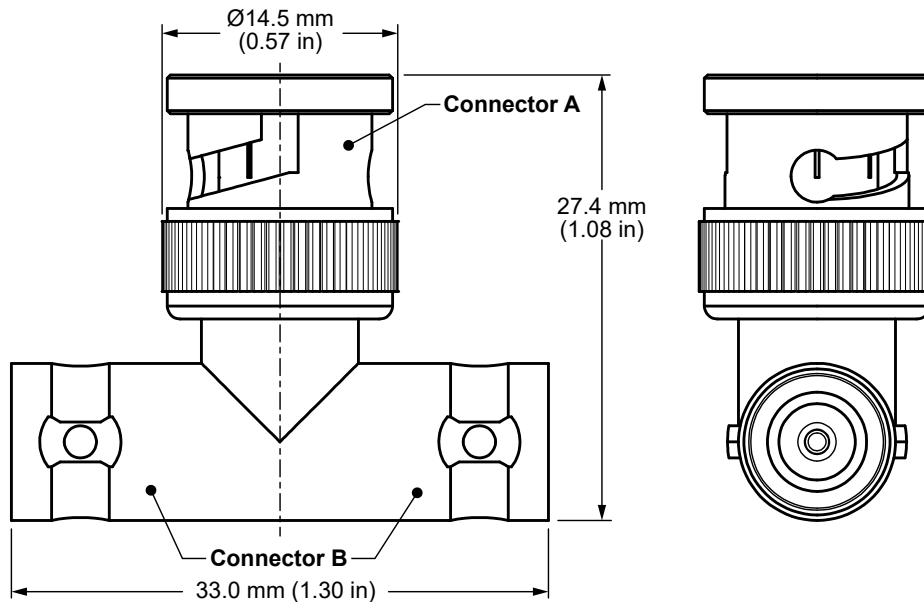

Figure 1. Product Dimensions for the ADP-BNCF-T Adapter

Table 2. Adapter Components

ADP-BNCF-T	Connector A BNC plug (male pin)		Connector B BNC jack (female socket)	
	Material	Finish	Material	Finish
Connector Part				
Body	Zinc	Nickel	Zinc	Nickel
Center Contact	Brass	Gold	Brass	Gold
Insulator	Delrin	–	Delrin	–

Table 3. Mechanical Specifications

ADP-BNCF-T	Connector A BNC plug (male pin)	Connector B BNC jack (female socket)
Mounting Type	Inline, Free-hanging	
Fastening Type	Bayonet-style Coupling (Push/Twist)	Bayonet-style Coupling (Push/Twist)
Interface in Accordance with	MIL-STD-348B	MIL-STD-348B
Durability	500 cycles min.	500 cycles min.
Weight	13.7 g (0.48 oz)	

Table 4. Environmental Specifications

MIL-STD, Method, Test Condition	
Corrosion (Salt spray)	MIL-STD-202 Method 101 test condition B
Thermal Shock	MIL-STD-202 Method 107 test condition C
Vibration	MIL-STD-202 Method 204 test condition B
Mechanical Shock	MIL-STD-202 Method 213 test condition B
Moisture Resistance	MIL-STD-202 Method 106 test condition D
Temperature Range	-65 °C to +165 °C
Environmental Compliance	RoHS

Insertion Loss

Figure 2 shows the Insertion Loss for the ADP-BNCM-BNCF-T adapter. Insertion loss is the loss of signal power (gain) resulting from the insertion of a device in a transmission line.

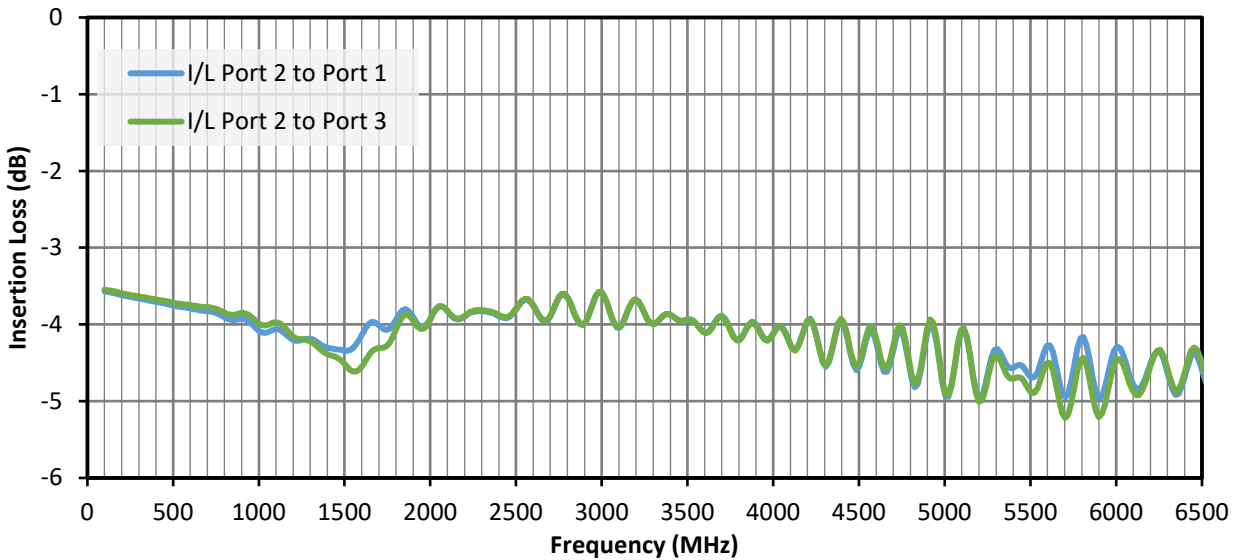

Figure 2. Insertion Loss for the ADP-BNCM-BNCF-T Adapter

VSWR

Figure 3 provides the voltage standing wave ratio (VSWR) across the adapter's bandwidth for the ADP-BNCM-BNCF-T adapter. VSWR describes how efficiently power is transmitted. A lower VSWR value indicates better performance at a given frequency.

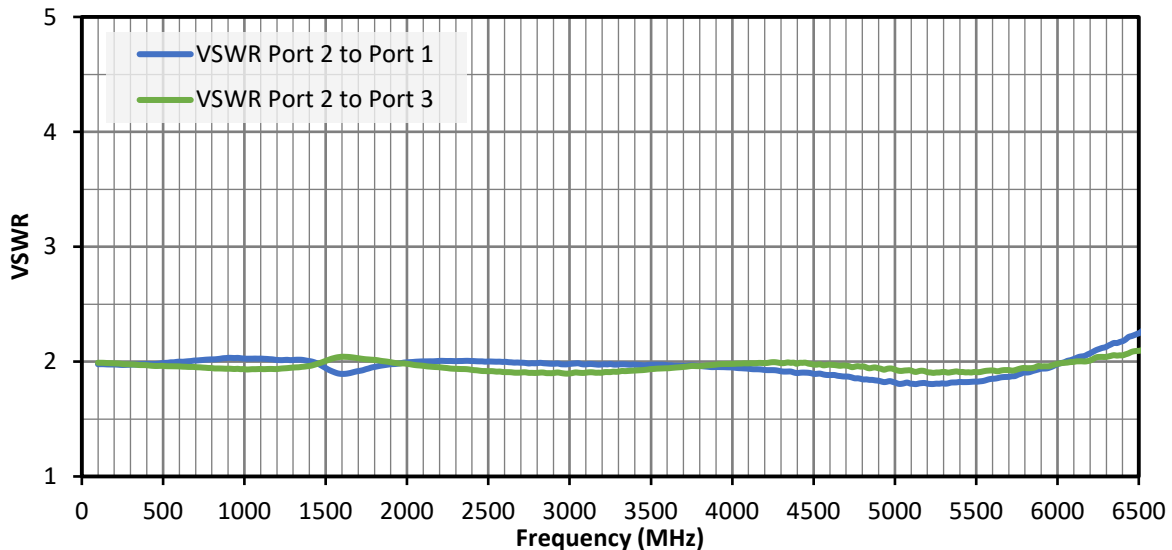

Figure 3. VSWR for the ADP-BNCM-BNCF-T Adapter

Packaging Information

The ADP-BNCM-BNCF-T adapter is individually placed in a clear polyethylene bag. 25 pcs are packaged in a larger protective bag. 750 pcs are packaged in a shipping carton (370 mm x 330 mm x 240 mm). Distribution channels may offer alternative packaging options.

Website: <http://linxtechnologies.com>
Linx Offices: 159 Ort Lane, Merlin, OR, US 97532
Phone: +1 (541) 471-6256
E-MAIL: info@linxtechnologies.com

Linx Technologies reserves the right to make changes to the product(s) or information contained herein without notice. No liability is assumed as a result of their use or application. No rights under any patent accompany the sale of any such product(s) or information.

Wireless Made Simple is a registered trademark of Linx Acquisitions LLC. Other product and brand names may be trademarks or registered trademarks of their respective owners.

Copyright © 2022 Linx Technologies

All Rights Reserved

Doc# DS22310-275CON

