

Customer Information Sheet

DRAWING No.: M22-271XXXX

SHEET 2 OF 2

IF IN DOUBT - ASK

©

NOT TO SCALE

THIRD ANGLE PROJECTION

ALL DIMENSIONS IN mm

ORDER CODE:

M22-271XXXX

No. OF CONTACTS: _____
02 TO 20

FINISH: _____
05 = GOLD OVER NICKEL
46 = 100% TIN OVER NICKEL

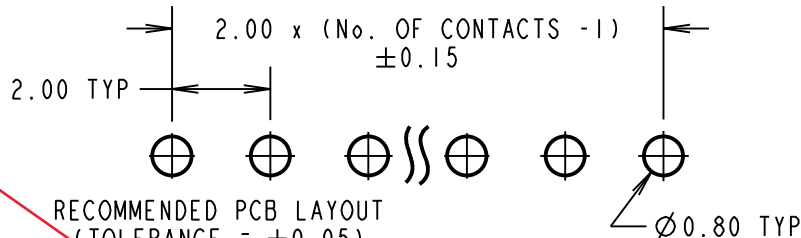

RECOMMENDED PCB LAYOUT
(TOLERANCE = ±0.05)

SPECIFICATIONS:

MATERIAL:
MOULDING = NYLON 6T, UL94V-0, BLACK
CONTACTS = PHOSPHOR BRONZE
FINISH:
05 = GOLD FLASH OVER NICKEL
46 = 100% TIN OVER NICKEL
ELECTRICAL:
CURRENT RATING = 2A
VOLTAGE PROOF = 500V AC FOR ONE MINUTE
CONTACT RESISTANCE = 20mΩ MAX
INSULATION RESISTANCE = 1,000 MΩ MIN
MECHANICAL:
DURABILITY = 300 OPERATIONS MIN
ENVIRONMENTAL:
TEMPERATURE RANGE = -40°C TO +105°C
PACKING:
BAG
FOR COMPLETE SPECIFICATION, SEE
COMPONENT SPECIFICATION C018XX (LATEST ISSUE)

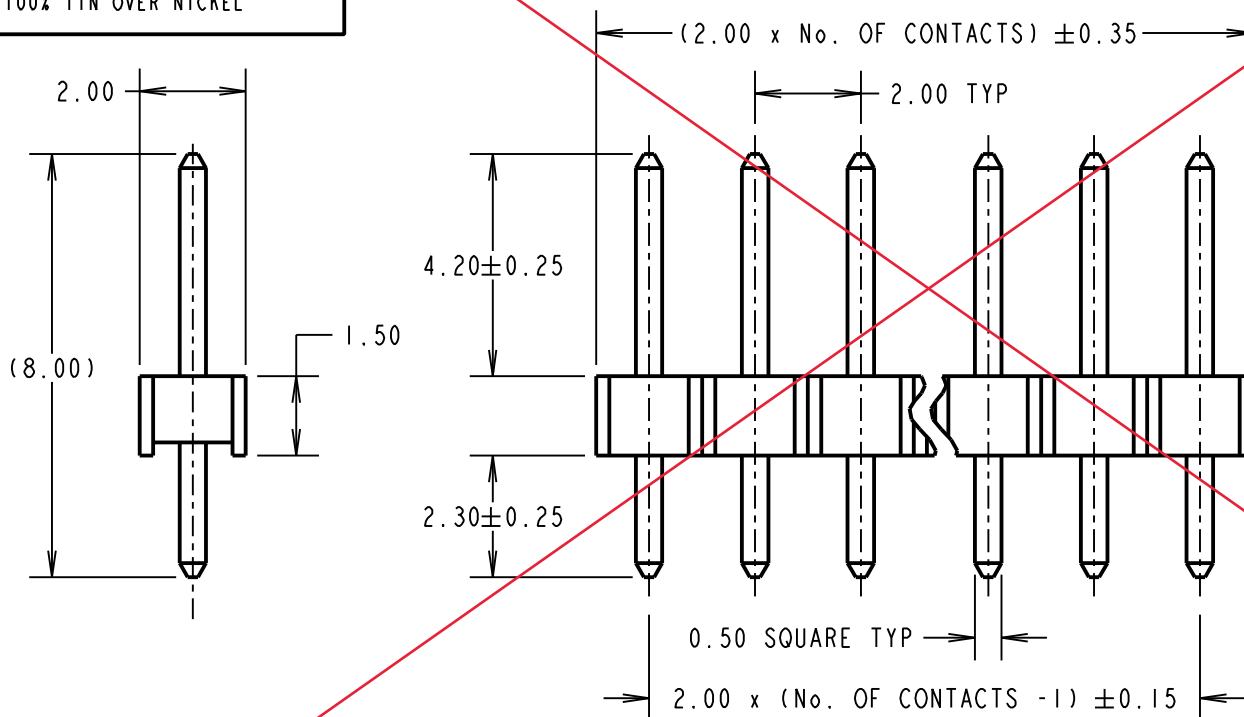

OBSOLETE

NOTES:

1. ALL TOLERANCES ARE ±0.20 UNLESS OTHERWISE STATED.

MSP	4	15.06.15	12803
NAME	ISS.	DATE	C/NOTE
APPROVED:		M.PERREN	
CHECKED:		S.BENNETT	
DRAWN:		S.BENNETT	
CUSTOMER REF.:			
ASSEMBLY DRG:			

HARWIN

www.harwin.com
technical@harwin.com

THIS DRAWING AND ANY INFORMATION OR DESCRIPTIVE MATTER SET OUT HEREON ARE CONFIDENTIAL AND COPYRIGHT PROPERTY OF THE HARWIN GROUP AND MUST NOT BE DISCLOSED, LOANED, COPIED OR USED FOR MANUFACTURING, TENDERING OR FOR ANY OTHER PURPOSE WITHOUT THEIR WRITTEN PERMISSION.

TOLERANCES
~~X. = ±1mm~~
~~X.X = ±0.50mm~~
~~X.XX = ±0.10mm~~
~~X.XXX = ±0.01mm~~
ANGLES = ±5°
UNLESS STATED

MATERIAL:

SEE ABOVE

FINISH:

SEE ABOVE

S/AREA:

mm²

TITLE:

2.00mm PITCH SMT VERTICAL
PIN HEADER ASSEMBLY

DRAWING NUMBER:

M22-271XXXX

SHT
2
OF
2