

**RIGHT ANGLE PLUG CRIMP TYPE  
CABLE 2.6/50 S**

**R124.172.120**  
**SERIES SMA-COM**

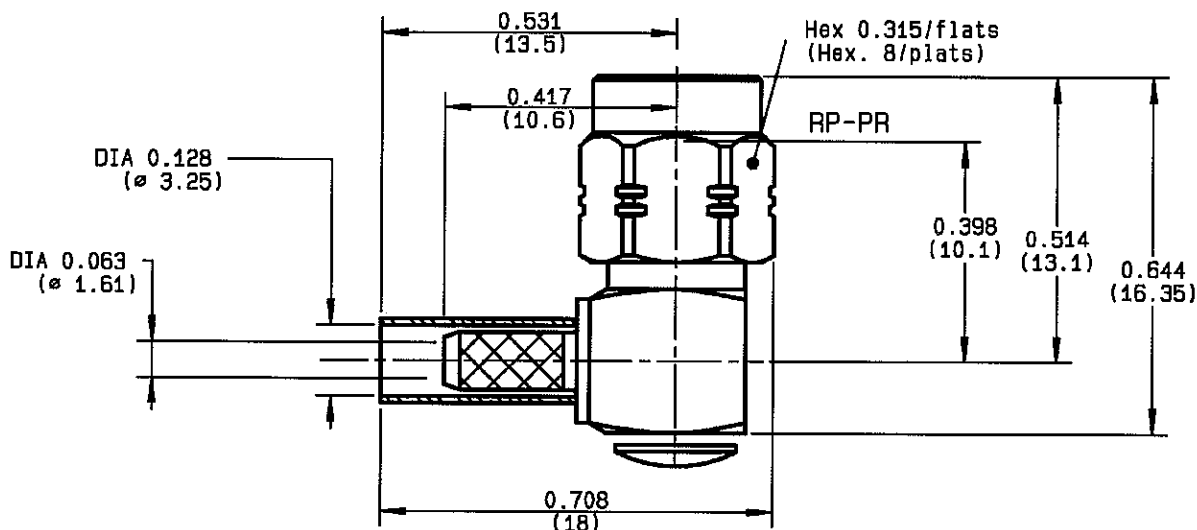

NOMINAL IMPEDANCE	<b>50</b> Ω
FREQUENCY RANGE	<b>0-12.4</b> GHz
TEMPERATURE RATING	<b>-65/+165</b> °C
V.S.W.R	<b>1.15 + .03 x F(GHz)Maxi</b>
RF INSERTION LOSS	<b>0.05 √F(GHz) dB Maxi</b>
VOLTAGE RATING	<b>250</b> V <sub>eff</sub> Maxi
DIELECTRIC WITHSTANDING VOLTAGE	<b>750</b> V <sub>eff</sub> Mini
INSULATION RESISTANCE	<b>5000</b> MΩMini
HERMETIC SEAL	<b>NA</b> Atm.cm <sup>3</sup> /s
LEAKAGE (pressurized only)	<b>NA</b>
MECHANICAL DURABILITY	<b>100</b> Cycles
WEIGHT	<b>4.75</b> gr
SPECIFICATION	

CABLES : **KX 22A**  
**RG 188**  
**RG 316**

OTHERS CHARACTERISTICS

CABLE RETENTION	<b>90</b> N Mini
CENTER CONTACT RETENTION	
Axial force - mating end	<b>27</b> N Mini
Axial force - opposite end	<b>27</b> N Mini
Torque	<b>NA</b> cm.N Mini
RECOMMENDED TORQUES	
Mating	<b>60</b> cm.N
Panel nut	<b>NA</b> cm.N
Clamp nut	<b>NA</b> cm.N

CONNECTOR PARTS	MATERIALS	FINISH	(all values are given in micrometers)
BODY	BRASS	BBR 2	
OUTER CONTACT			
CENTER CONTACT	BRASS	GOLD 1.3 OVER COPPER 2.5	
INSULATOR	PTFE	-	
GASKET		-	
OTHERS PIECES	BRASS	BBR 2	

TRIGUES

ISSUE  
**0708E**

CREATION DATE  
**30/06/1993**

FILE PART-NUMBER  
**EPC 97-03**



**RADIALL®**

The information given here is subject to change without notice.  
Design changes may be in order to improve the product.

*Connect to the future*



**R124.172.120**

ISSUE **0708E** SERIES **SMA-COM**

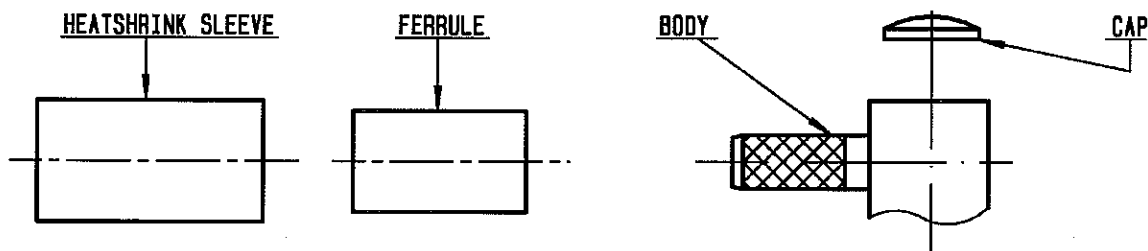

①

Slide heatshrink sleeve (R280.637.020 - Option) and the ferrule onto cable .  
Strip the cable .

-  
-

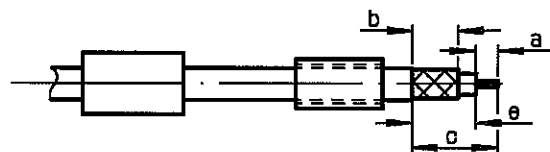

Stripping	a	b	c	d	e
inch	0.079	0.256	0.472	0	0.394
mm	2	6.5	12		10

②

Fan the braid .  
Push connector body under the braid .  
Slide ferrule over braid  
( in direction F )

-  
-

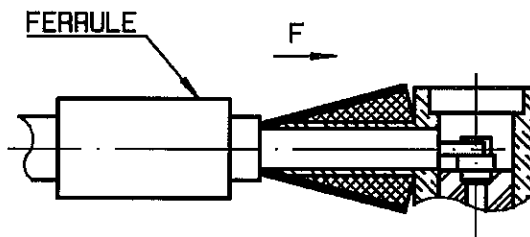

③

Crimp the ferrule with crimping tool R282 211 000 ( Hex. : 0.128 ) or crimping tool R 282 293 000 ( M22520/5-01 ) + dies R 282 295 003 ( M22520/5-03 )  
Solder inner conductor .

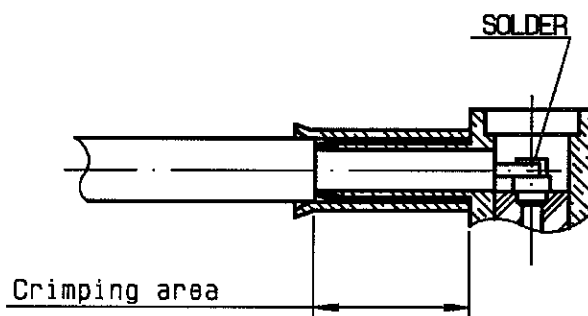

④

Place the cap into body .  
Press cap flush or slightly below surface of body assembly .  
Slide sleeve over ferrule and heatshrink in place (Option) .

-  
-  
-

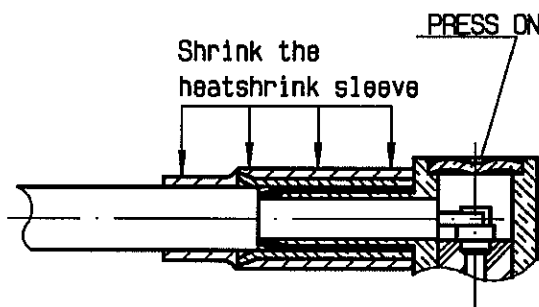

TRIGUES