

THIS DRAWING CONTAINS INFORMATION PROPRIETARY TO RF INDUSTRIES,
 ANY UNAUTHORIZED USE OF THIS DRAWING IS EXPRESSLY PROHIBITED
 WITHOUT WRITTEN PERMISSION FROM RF INDUSTRIES.
 ANY VIOLATION IS PUNISHABLE UNDER U.S. COPYRIGHT LAWS.

ALL DIMENSIONS ARE REFERENCE ONLY

PART NO.

RFT-1202-7

| REV | DESCRIPTION | DWN | DATE | APPROVED |
|-----|---------------------|-----|----------|----------|
| - | ENGINEERING RELEASE | CZS | 02/07/08 | JDMc |
| | | | | |
| | | | | |

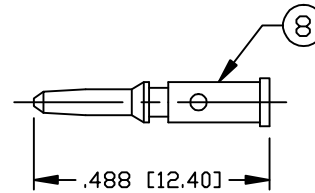
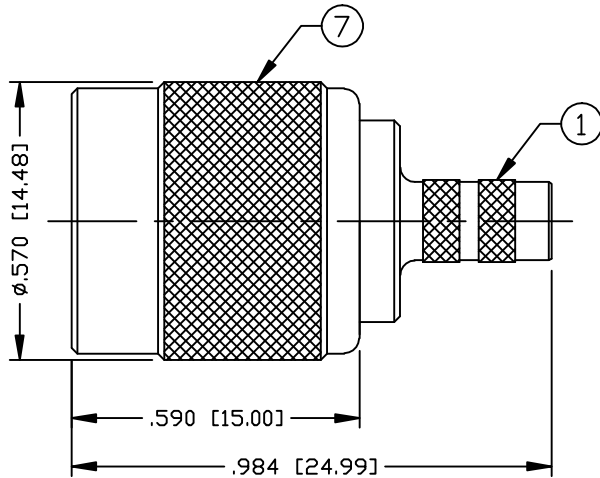

RECOMMENDED CRIMP DIE: .068"

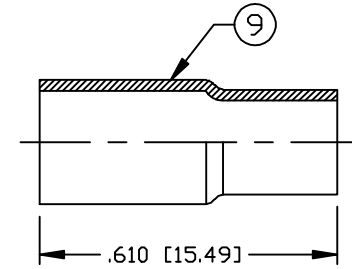

RECOMMENDED CRIMP DIE: .213"

SPECIFICATIONS:

IMPEDANCE: 50 Ohms
 FREQUENCY RANGE: 0-7 GHz
 WORKING VOLTAGE: 500 V rms @ sea level
 INSULATION RESISTANCE: 5k M ohms min.
 TEMPERATURE RANGE: -65°C TO +85°C
 FOR MOTOROLA WHITE TEFLON, BELDEN 82907, 88240 &
 89907, RG-122/U & TIMES MSI-15 CABLE

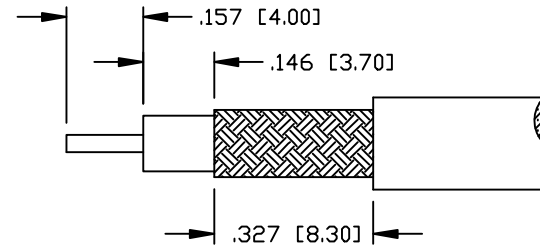

RECOMMENDED STRIPPING INSTRUCTIONS

| 1 | BODY | 1 | BRASS | NICKEL, 100μ" | 008974 | |
|----|----------------|-----|----------|---------------|-----------|----------|
| 2 | INSULATOR | 1 | DELTRIN | ---- | | |
| 3 | WASHER | 1 | BRASS | NICKEL, 100μ" | | |
| 4 | RING | 1 | DELTRIN | ---- | | |
| 5 | RETAINING RING | 1 | BRASS | NICKEL, 100μ" | | |
| 6 | GASKET | 1 | RUBBER | ---- | | |
| 7 | SHELL | 1 | BRASS | NICKEL, 100μ" | | |
| 8 | PIN | 1 | BRASS | GOLD, 3μ" | | |
| 9 | FERRULE | 1 | BRASS | NICKEL, 100μ" | | |
| 10 | | | | | DRAWN | |
| 11 | | | | | C. ZUNIGA | 02/07/08 |
| 12 | | | | | CHECKED | |
| 13 | | | | | ORJ DRAWN | |
| 14 | | | | | C. ZUNIGA | 11/11/97 |
| # | DESCRIPTION | QTY | MATERIAL | FINISH | APPROVALS | DATE |

**RoHS
COMPLIANT**

DIMENSIONS ARE IN INCHES
 AND [MILLIMETERS]
 UNLESS OTHERWISE NOTED
 TOLERANCES ARE:
 DECIMALS DIAMETER

RFconnectors
 DIVISION OF RF INDUSTRIES, LTD.

7610 MIRAMAR RD
 SAN DIEGO, CA 92126
 (858) 549-6340
 (858) 549-6345 FAX

TNC PLUG, CRIMP

| | | | |
|--------|-------------|------------|--------------|
| SIZE | CABLE GROUP | DWG NO. | REV |
| A | M | RFT-1202-7 | - |
| SCALE: | NTS | CAD FILE | OUTLINE |
| | | | SHEET 1 OF 1 |