

LOC	DIST	REVISIONS					
AD	14	P	LTR	DESCRIPTION	DATE	DWN	APVD
		0		DRAWN	01OCT98	RB	DD
		A		REV PER EC OG51-0294-98	01/20/99	MM	DD
		B		REVISED PER OG51-0025-99	01FEB99	RB	DD
		C		REV PER OG51-0062-99	05/18/99	MM	EL
		C1		REVISED PER ECO-09-020689	31AUG09	KK	AEG
		C2		REVISED PER ECO-09-024465	02NOV09	FL	SY

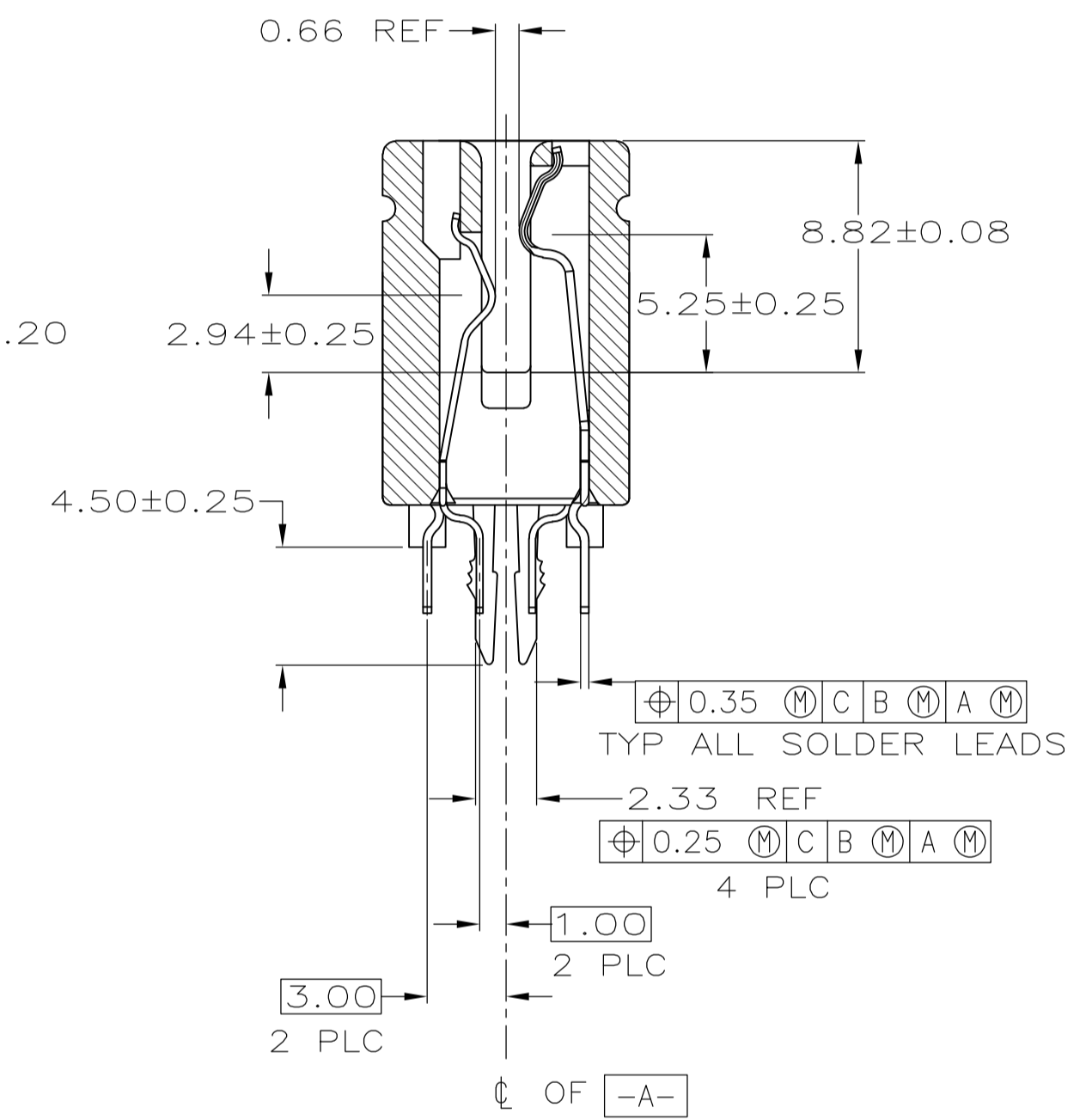
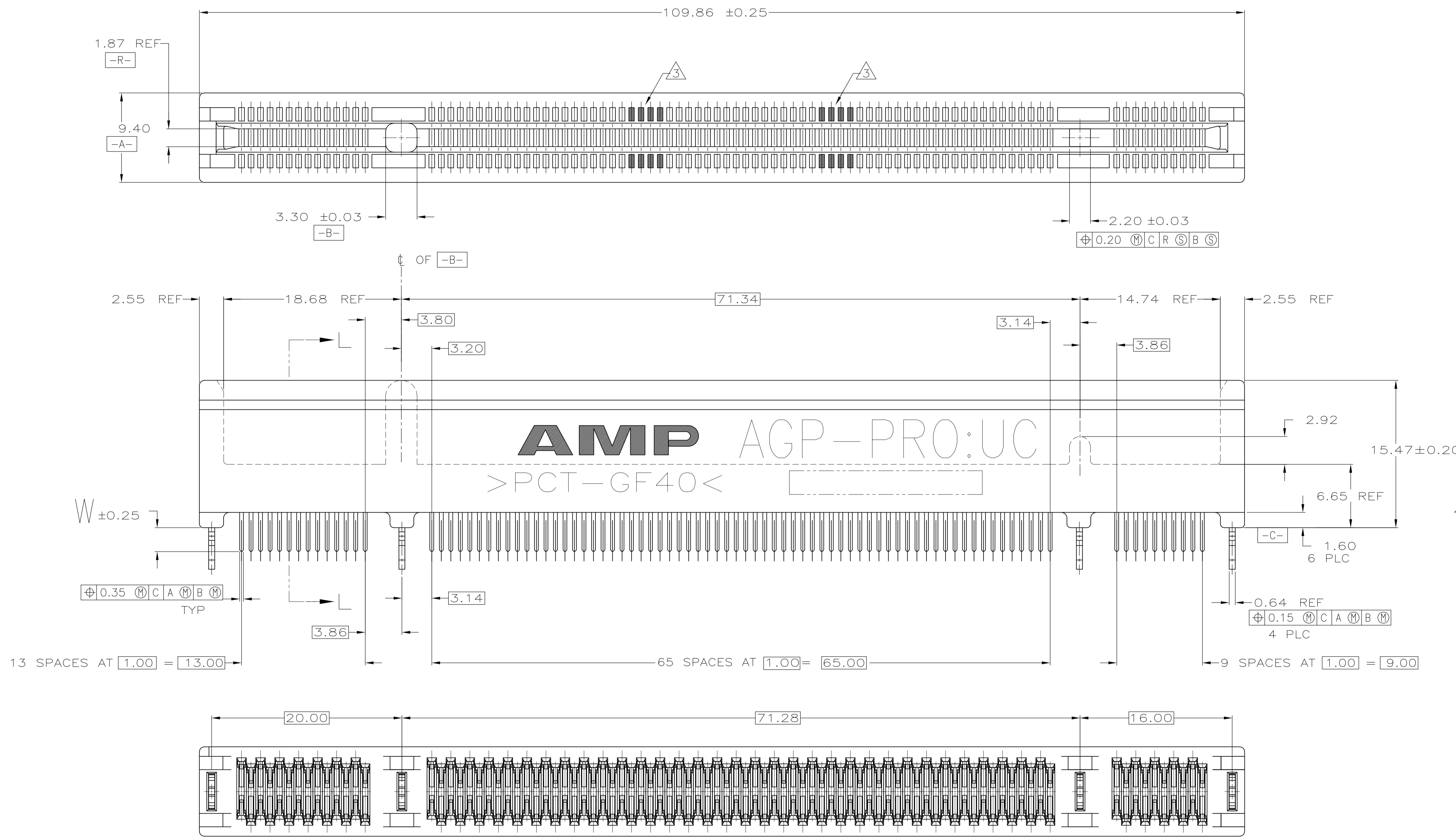

- △ MATERIAL: HOUSING, THERMOPLASTIC, COLOR: BROWN.  
CONTACTS, PHOSPHOR BRONZE.  
FASTENERS, BRASS.
- △ FINISH: CONTACTS, 1.27 MIN. MICROMETERS NICKEL ALL OVER,  
0.38 MIN. MICROMETERS GOLD OVER NICKEL IN CONTACT AREA,  
2.54 MIN MICROMETERS TIN-LEAD OVER NICKEL ON SOLDER LEADS.
- △ SHADED CONTACT LOCATIONS ARE AT RISK OF DAMAGE DURING MATING AND  
UNMATING WITH AGP-1X AND AGP-2X/4X CIRCUITS.
- △ FINISH: FASTENERS, 1.27 MIN. MICROMETERS NICKEL ALL OVER,  
3.81 MIN MICROMETERS BRIGHT TIN-LEAD OVER NICKEL.
- △ FINISH: CONTACTS, 1.27 MIN. MICROMETERS NICKEL ALL OVER,  
0.0254-0.0762 MICROMETERS GOLD OVER NICKEL IN CONTACT AREA.  
2.54 MIN. MICROMETERS TIN-LEAD OVER NICKEL ON SOLDER TAILS.
- △ OBSOLETE PARTS: OBSOLETE CIS STREAMLINING PER D.RENAUD/D.SINISI

△ OBSOLETE	△ △	3.18	145409-6
	△ △	2.54	145409-5
△ OBSOLETE	△ △	3.18	145409-3
	△ △	2.54	145409-2
△ OBSOLETE	△ △	2.16	145409-1
		PLATING	W
		PART NO	

THIS DRAWING IS A CONTROLLED DOCUMENT.

DIMENSIONS:	TOLERANCES UNLESS OTHERWISE SPECIFIED:	DWN Francis Lee 02NOV09	AMP Incorporated Harrisburg, PA 17105-3608
mm		CHK Martin Li 02NOV09	
0 PLC ±-		APVD Steven Yao 02NOV09	NAME
1 PLC ±-		PRODUCT SPEC	CONNECTOR ASSEMBLY,
2 PLC ±0.13		APPLICATION SPEC	STANDARD EDGE, 1mm, AGP-PRO:UC,
3 PLC ±-		WEIGHT	180 POSITION
4 PLC ±-	#2"	SIZE	A1
ANGLES		CAGE CODE	00779
		DRAWING NO	C-145409
MATERIAL	FINISH	SCALE	4:1
△	△	SHEET	1 of 2
CUSTOMER DRAWING		REV	Q

