

## DLP2000 (.2 nHD) DMD

### 1 Features

- Ultra compact 0.2-Inch (5.55-mm) diagonal micromirror array
  - 640 × 360 array of aluminum micrometer-sized mirrors, in an orthogonal layout
  - 7.56-Micron micromirror pitch
  - 12° micromirror tilt (relative to flat surface)
  - Corner illumination for optimal efficiency and optical engine size
- Dedicated DLPC2607 display controller and DLPA1000 PMIC/LED driver for reliable operation

### 2 Applications

- Internet of Things (IoT) devices including:
  - Control panels
  - Security systems
  - Thermostats
- Wearable displays
- Embedded displays for products including:
  - Tablets
  - Cameras
  - Artificial intelligence (AI) assistants
- Micro digital signage
- Ultra-low power smart accessory projector

### 3 Description

The DLP2000 digital micromirror device (DMD) is a digitally controlled micro-opto-electromechanical system (MOEMS) spatial light modulator (SLM). When coupled to an appropriate optical system, the DLP2000 DMD displays a crisp and high quality image or video. DLP2000 is part of the chipset comprising of the DLP2000 DMD and [DLPC2607](#) display controller. This chipset is also supported by the [DLPA1000](#) PMIC/LED driver. The compact physical size of the DLP2000 is well-suited for portable equipment where small form factor and low power is important. The compact package compliments the small size of LEDs to enable highly efficient, robust light engines.

Visit the [getting started with TI DLP®Pico™ display technology](#) page to learn how to get started with the DLP2000 DMD.

The DLP2000 includes established resources to help the user accelerate the design cycle, which include [production ready optical modules](#), [optical modules manufactures](#), and [design houses](#).

#### Device Information<sup>(1)</sup>

PART NUMBER	PACKAGE	BODY SIZE (NOM)
DLP2000	FQC (42)	14.12 mm × 4.97 mm

(1) For all available packages, see the orderable addendum at the end of the data sheet.

#### Simplified Application

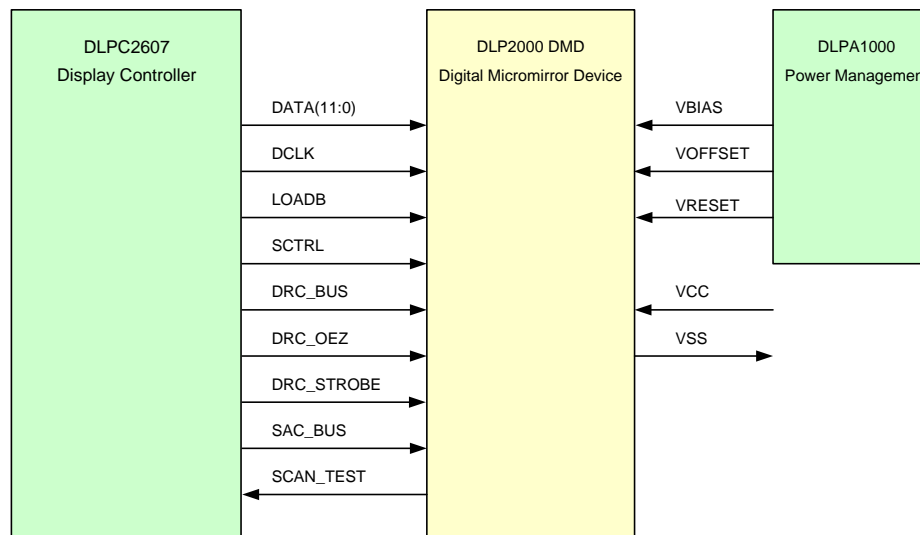

## Table of Contents

<b>1 Features</b> .....	<b>1</b>	7.4 Device Functional Modes.....	<b>18</b>
<b>2 Applications</b> .....	<b>1</b>	7.5 Window Characteristics and Optics .....	<b>18</b>
<b>3 Description</b> .....	<b>1</b>	7.6 Micromirror Array Temperature Calculation.....	<b>19</b>
<b>4 Revision History</b> .....	<b>2</b>	7.7 Micromirror Landed-On/Landed-Off Duty Cycle ....	<b>20</b>
<b>5 Pin Configuration and Functions</b> .....	<b>3</b>	<b>8 Application and Implementation</b> .....	<b>23</b>
<b>6 Specifications</b> .....	<b>7</b>	8.1 Application Information.....	<b>23</b>
6.1 Absolute Maximum Ratings .....	<b>7</b>	8.2 Typical Application .....	<b>23</b>
6.2 Storage Conditions.....	<b>7</b>	<b>9 Power Supply Recommendations</b> .....	<b>25</b>
6.3 ESD Ratings .....	<b>7</b>	9.1 Power Supply Power-Up Procedure .....	<b>25</b>
6.4 Recommended Operating Conditions.....	<b>8</b>	9.2 Power Supply Power-Down Procedure.....	<b>25</b>
6.5 Thermal Information .....	<b>9</b>	<b>10 Layout</b> .....	<b>28</b>
6.6 Electrical Characteristics.....	<b>9</b>	10.1 Layout Guidelines .....	<b>28</b>
6.7 Timing Requirements.....	<b>10</b>	10.2 Layout Example .....	<b>28</b>
6.8 System Mounting Interface Loads .....	<b>12</b>	<b>11 Device and Documentation Support</b> .....	<b>30</b>
6.9 Physical Characteristics of the Micromirror Array ..	<b>13</b>	11.1 Device Support .....	<b>30</b>
6.10 Micromirror Array Optical Characteristics .....	<b>15</b>	11.2 Related Links .....	<b>30</b>
6.11 Window Characteristics.....	<b>15</b>	11.3 Community Resources.....	<b>30</b>
6.12 Chipset Component Usage Specification .....	<b>16</b>	11.4 Trademarks .....	<b>30</b>
<b>7 Detailed Description</b> .....	<b>17</b>	11.5 Electrostatic Discharge Caution.....	<b>31</b>
7.1 Overview .....	<b>17</b>	11.6 Glossary .....	<b>31</b>
7.2 Functional Block Diagram .....	<b>17</b>	<b>12 Mechanical, Packaging, and Orderable Information</b> .....	<b>32</b>
7.3 Feature Description.....	<b>18</b>		

## 4 Revision History

DATE	REVISION	NOTES
April 2019	*	Initial release

## 5 Pin Configuration and Functions

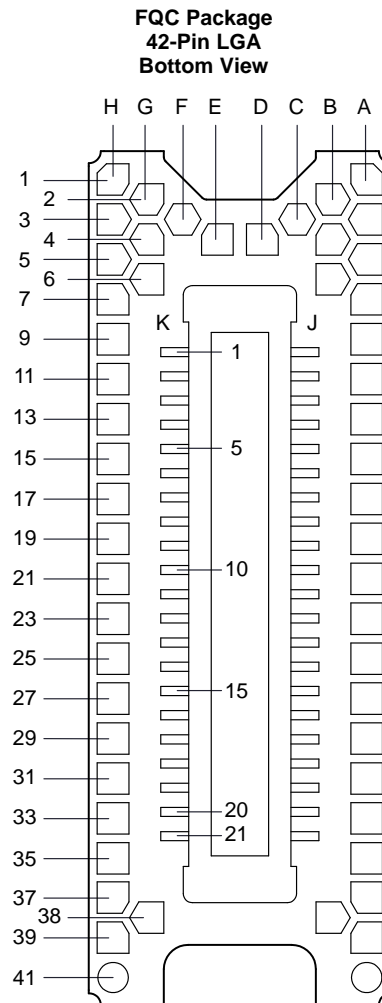

**Pin Functions**

PIN		TYPE	SIGNAL	DATA RATE	DESCRIPTION	PACKAGE NET LENGTH (mm)
NAME	NO.					
<b>DATA INPUTS</b>						
DATA(0)	J13	Input	LVC MOS	DDR	Input Data Bus.	8.83
DATA(1)	J2	Input	LVC MOS	DDR	Input Data Bus.	7.53
DATA(2)	J4	Input	LVC MOS	DDR	Input Data Bus.	6.96
DATA(3)	J6	Input	LVC MOS	DDR	Input Data Bus.	7.05
DATA(4)	J7	Input	LVC MOS	DDR	Input Data Bus.	7.56
DATA(5)	J8	Input	LVC MOS	DDR	Input Data Bus.	7.07
DATA(6)	J12	Input	LVC MOS	DDR	Input Data Bus.	7.61
DATA(7)	J10	Input	LVC MOS	DDR	Input Data Bus.	7.68
DATA(8)	K4	Input	LVC MOS	DDR	Input Data Bus.	7.31
DATA(9)	K2	Input	LVC MOS	DDR	Input Data Bus.	6.76
DATA(10)	K7	Input	LVC MOS	DDR	Input Data Bus.	8.18
DATA(11)	K6	Input	LVC MOS	DDR	Input Data Bus.	7.81
DCLK	K9	Input	LVC MOS		Input Data Clock.	7.78
<b>CONTROL INPUTS</b>						

**Pin Functions (continued)**

PIN		TYPE	SIGNAL	DATA RATE	DESCRIPTION	PACKAGE NET LENGTH (mm)
NAME	NO.					
LOADB	K10	Input	LVC MOS	DDR	Parallel Latch Load Enable.	7.64
SCTRL	K12	Input	LVC MOS	DDR	Serial Control (Sync).	8.62
DRC_BUS	K14	Input	LVC MOS		Reset Control Serial Bus. Synchronous to Rising Edge of DCLK. Bond Pad does Not connect to internal Pull Down	7.28
DRC_OEZ	K18	Input	LVC MOS		Active Low. Output Enable signal for internal Reset Driver circuitry. Bond Pads do Not connect to internal Pull Down	4.69
DRC_STROBE	J15	Input	LVC MOS		Rising Edge on DRC_STROBE latches in the Control Signals. Synchronous to Rising Edge of DCLK. Bond Pad does Not connect to internal Pull Down	7.61
SAC_BUS	K16	Input	LVC MOS		Stepped Address Control Serial Bus. Synchronous to Rising Edge of DCLK. Bond Pad does Not connect to internal Pull Down	8.17
SCAN_TEST	K20	Input	LVC MOS		MUX'ed output for scanned chip id	1.18
<b>POWER</b>						
VBIAS	J16	Power			Power supply for Positive Bias level of Mirror Reset signal	
VOFFSET	K15	Power			Power Supply for High Voltage CMOS logic. Power Supply for Stepped High Voltage at Mirror Address Electrodes. Power supply for Offset level of Mirror Reset signal	
VRESET	J20	Power			Power supply for Negative Reset level of Mirror Reset signal	
VCC	J1	Power			Power Supply for Low Voltage CMOS logic. Power Supply for Normal High Voltage at Mirror Address Electrodes. Power supply for Offset level of Mirror Reset signal during Power Down	
VCC	J11	Power				
VCC	J21	Power				
VCC	K1	Power				
VCC	K11	Power				
VCC	K21	Power				
VSS	J3	Power			Common return. Ground for all power.	
VSS	J5	Power				
VSS	J9	Power				
VSS	J14	Power				
VSS	J17	Power				
VSS	J18	Power				
VSS	J19	Power				
VSS	K3	Power				
VSS	K5	Power				
VSS	K8	Power				
VSS	K13	Power				
VSS	K17	Power				
VSS	K19	Power				

**Pin Functions - Test Pads**

Electrical Test Pad	DLP® System Board
A1	Do Not Connect
A3	Do Not Connect
A5	Do Not Connect
A7	Do Not Connect
A9	Do Not Connect
A11	Do Not Connect
A13	Do Not Connect
A15	Do Not Connect
A17	Do Not Connect
A19	Do Not Connect
A21	Do Not Connect
A23	Do Not Connect
A25	Do Not Connect
A27	Do Not Connect
A29	Do Not Connect
A31	Do Not Connect
A33	Do Not Connect
A35	Do Not Connect
A37	Do Not Connect
A39	Do Not Connect
A41	Do Not Connect
B2	Do Not Connect
B4	Do Not Connect
B6	Do Not Connect
B38	Do Not Connect
C3	Do Not Connect
D4	Do Not Connect
E4	Do Not Connect
F3	Do Not Connect
G2	Do Not Connect
G4	Do Not Connect
G6	Do Not Connect
G38	Do Not Connect
H1	Do Not Connect
H3	Do Not Connect
H5	Do Not Connect
H7	Do Not Connect
H9	Do Not Connect
H11	Do Not Connect
H13	Do Not Connect
H15	Do Not Connect
H17	Do Not Connect
H19	Do Not Connect
H21	Do Not Connect
H23	Do Not Connect
H25	Do Not Connect
H27	Do Not Connect

**Pin Functions - Test Pads (continued)**

Electrical Test Pad	DLP® System Board
H29	Do Not Connect
H31	Do Not Connect
H33	Do Not Connect
H35	Do Not Connect
H37	Do Not Connect
H39	Do Not Connect
H41	Do Not Connect

## 6 Specifications

### 6.1 Absolute Maximum Ratings

over operating free-air temperature range (unless otherwise noted)<sup>(1)</sup>

			MIN	MAX	UNIT
Supply Voltage	V <sub>CC</sub>	LVC MOS Logic Supply Voltage <sup>(2)</sup>	-0.5	4	V
	V <sub>OFFSET</sub>	Mirror Electrode and HVCMOS Voltage <sup>(2)</sup>	-0.5	8.75	V
	V <sub>BIAS</sub>	Mirror Electrode Voltage	-0.5	17	V
	V <sub>BIAS</sub> - V <sub>OFFSET</sub>	Supply Voltage Delta <sup>(3)</sup>		8.75	V
	V <sub>RESET</sub>	Mirror Electrode Voltage	-11	0.5	V
Input Voltage	Input voltage: other inputs	See <sup>(2)</sup>	-0.5	V <sub>CC</sub> + 0.3	V
Clock Frequency	D <sub>CLK</sub>	Clock Frequency <sup>(4)</sup>	60	80	MHz
Environmental	T <sub>ARRAY</sub> and T <sub>WINDOW</sub>	Temperature – operational <sup>(5)</sup>	-20	90	°C
		Temperature – non-operational <sup>(5)</sup>	-40	90	°C
	T <sub>DP</sub>	Dew Point Temperature - operating and non-operating (non-condensing)		See Note <sup>(6)</sup>	°C
	T <sub>DELTA</sub>	Absolute Temperature delta between any point on the window edge and the ceramic test point TP1 <sup>(7)</sup>		30	°C

- (1) Stresses beyond those listed under *Absolute Maximum Ratings* may cause permanent damage to the device. These are stress ratings only, which do not imply functional operation of the device at these or any other conditions beyond those indicated under *Recommended Operating Conditions*. Exposure to absolute-maximum-rated conditions for extended periods may affect device reliability.
- (2) All voltage values are with respect to GND (V<sub>SS</sub>). V<sub>OFFSET</sub>, V<sub>CC</sub>, V<sub>BIAS</sub>, V<sub>RESET</sub> and V<sub>SS</sub> power supplies are required for the normal DMD operating mode.
- (3) To prevent excess current, the supply voltage delta |V<sub>BIAS</sub> - V<sub>OFFSET</sub>| must be less than 8.75 V.
- (4) BSA to Reset Timing specifications are synchronous and guaranteed for D<sub>CLK</sub> between 60 MHz and 80 MHz.
- (5) The highest temperature of the active array (as calculated by the [Micromirror Array Temperature Calculation](#)) or of any point along the Window Edge as defined in [Figure 10](#).
- (6) The DLP2000 DMD is intended for use in well controlled, low dew point environments. Please contact your local TI sales person or TI distributor representative to determine if this device is suitable for your application and operating environment compared to other DMD solutions. DLP® Products offers a broad portfolio of DMDs suitable for a wide variety of applications.
- (7) Temperature delta is the highest difference between the ceramic test point 1 (TP1) and anywhere on the window edge as shown in [Figure 10](#).

### 6.2 Storage Conditions

Applicable before the DMD is installed in the final product

			MIN	MAX	UNIT
T <sub>DMD</sub>	DMD Temperature		-40	85	°C
T <sub>DP</sub>	Dew Point Temperature	(non-condensing)		See Note <sup>(1)</sup>	°C

- (1) The DLP2000 DMD is intended for use in well controlled, low dew point environments. Please contact your local TI sales person or TI distributor representative to determine if this device is suitable for your application and operating environment compared to other DMD solutions. DLP Products offers a broad portfolio of DMDs suitable for a wide variety of applications.

### 6.3 ESD Ratings

			VALUE	UNIT
V <sub>(ESD)</sub>	Electrostatic discharge	Human-body model (HBM), per ANSI/ESDA/JEDEC JS-001 <sup>(1)</sup>	±2000	V

- (1) JEDEC document JEP155 states that 500-V HBM allows safe manufacturing with a standard ESD control process.

### 6.4 Recommended Operating Conditions

Over operating free-air temperature range (unless otherwise noted)

		MIN	NOM	MAX	UNIT		
Supply Voltage	V <sub>CC</sub>	LVCMOS Logic power supply voltage <sup>(1)</sup>		1.65	1.8	1.95	V
	V <sub>OFFSET</sub>	Mirror Electrode and HVCMOS voltage <sup>(1)</sup>		8.25	8.5	8.75	V
	V <sub>BIAS</sub>	Mirror Electrode Voltage		15.5	16	16.5	V
		Supply Voltage Delta  V <sub>BIAS</sub> – V <sub>OFFSET</sub>   <sup>(2)</sup>				8.75	V
V <sub>RESET</sub>	Mirror Electrode Voltage		–9.5	–10	–10.5	V	
Input Voltage	V <sub>P</sub>	Positive Going Threshold Voltage		0.4*V <sub>CC</sub>		0.7*V <sub>CC</sub>	V
	V <sub>N</sub>	Negative Going Threshold Voltage		0.3*V <sub>CC</sub>		0.6*V <sub>CC</sub>	V
	V <sub>H</sub>	Hysteresis Voltage (V <sub>p</sub> – V <sub>n</sub> )		0.1*V <sub>CC</sub>		0.4*V <sub>CC</sub>	V
Environmental	T <sub>ARRAY</sub>	Array Temperature – long-term operational <sup>(3)(4)(5)(6)</sup>		0		40 to 70	°C
		Array Temperature – short-term operational <sup>(4)(7)</sup>		–20		75	°C
	T <sub>DELTA</sub>	Absolute Temperature difference between any point on the window edge and the ceramic test point TP1 <sup>(8)</sup>				30	°C
	T <sub>WINDOW</sub>	Window Temperature – operational <sup>(3)(9)</sup>				90	°C
	T <sub>DP</sub>	Dew Point Temperature (non-condensing)		See Note <sup>(10)</sup>			°C
	ILL <sub>UV</sub>	Illumination wavelength < 400 nm <sup>(3)</sup>				0.68	mW/cm <sup>2</sup>
	ILL <sub>VIS</sub>	Illumination wavelengths between 400 nm and 700 nm		Thermally limited			
ILL <sub>IR</sub>	Illumination wavelength > 700 nm				10	mW/cm <sup>2</sup>	

- (1) All voltage values are with respect to GND (V<sub>SS</sub>). V<sub>OFFSET</sub>, V<sub>CC</sub>, V<sub>BIAS</sub>, V<sub>RESET</sub> and V<sub>SS</sub> power supplies are required for the normal DMD operating mode.
- (2) To prevent excess current, the supply voltage delta |V<sub>BIAS</sub> – V<sub>OFFSET</sub>| must be less than 8.75 V.
- (3) Simultaneous exposure of the DMD to the maximum [Recommended Operating Conditions](#) for temperature and UV illumination will reduce device lifetime.
- (4) The array temperature cannot be measured directly and must be computed analytically from the temperature measured at test point 1 (TP1) shown in [Figure 10](#) and the package thermal resistance using [Micromirror Array Temperature Calculation](#).
- (5) Per [Figure 1](#), the maximum operational array temperature should be derated based on the micromirror landed duty cycle that the DMD experiences in the end application. Refer to [Micromirror Landed-On/Landed-Off Duty Cycle](#) for a definition of micromirror landed duty cycle.
- (6) Long-term is defined as the usable life of the device
- (7) Array temperatures beyond those specified as long-term are recommended for short-term conditions only (power-up). Short-term is defined as cumulative time over the usable life of the device and is less than 500 hours for temperatures between the long-term maximum and 75°C, and less than 500 hours for temperatures between 0°C and –20°C.
- (8) Temperature delta is the highest difference between the ceramic test point 1 (TP1) and anywhere on the window edge as shown in [Figure 10](#).
- (9) Window temperature is the highest temperature on the window edge shown in [Figure 10](#).
- (10) The DLP2000 DMD is intended for use in well controlled, low dew point environments. Please contact your local TI sales person or TI distributor representative to determine if this device is suitable for your application and operating environment compared other DMD solutions. DLP Products offers a broad portfolio of DMDs suitable for a wide variety of applications.

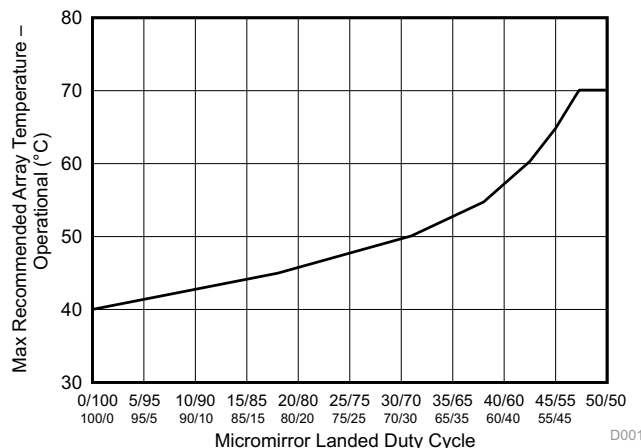

Figure 1. Max Recommended Array Temperature - Derating Curve



## 6.5 Thermal Information

THERMAL METRIC <sup>(1)</sup>	DLP2000	UNIT
	FQC (LGA)	
	42 PINS	
Thermal resistance active area to test point 1 (TP1) <sup>(1)</sup>	8	°C/W

- (1) The DMD is designed to conduct absorbed and dissipated heat to the back of the package. The cooling system must be capable of maintaining the package within the temperature range specified in the [Recommended Operating Conditions](#). The total heat load on the DMD is largely driven by the incident light absorbed by the active area; although other contributions include light energy absorbed by the window aperture and electrical power dissipation of the array. Optical systems should be designed to minimize the light energy falling outside the window aperture since any additional thermal load in this area can significantly degrade the reliability of the device.

## 6.6 Electrical Characteristics

over operating free-air temperature range (unless otherwise noted)

PARAMETER		TEST CONDITIONS	MIN	TYP	MAX	UNIT
V <sub>OH</sub>	High level output voltage	V <sub>CC</sub> = 1.65 V I <sub>OH</sub> = -2 mA	1.20			V
V <sub>OL</sub>	Low level output voltage	V <sub>CC</sub> = 1.95 V I <sub>OL</sub> = -2 mA			0.45	V
I <sub>IL</sub>	Low level input current <sup>(1)(2)</sup>	V <sub>CC</sub> = 1.95 V V <sub>I</sub> = 0 V			52	nA
I <sub>IH</sub>	High level input current <sup>(1)(2)</sup>	V <sub>CC</sub> = 1.95 V V <sub>I</sub> = 1.95 V	41			nA
<b>CURRENT</b>						
I <sub>CC</sub>	Current at V <sub>CC</sub> = 1.95 V	D <sub>CLK</sub> Frequency = 77 MHz			30	mA
I <sub>OFFSET</sub>	Current at V <sub>OFFSET</sub> = 8.75 V <sup>(3)</sup>				1.5	mA
I <sub>BIAS</sub>	Current at V <sub>BIAS</sub> = 16.5 V <sup>(3)(4)</sup>	3 Global Resets within time period = 200 μs			1.3	mA
I <sub>RESET</sub>	Current at V <sub>RESET</sub> = -10.5 V	3 Global Resets within time period = 200 μs			1.2	mA
<b>POWER</b>						
P <sub>CC</sub>	Power at V <sub>CC</sub> = 1.95 V <sup>(5)</sup>	D <sub>CLK</sub> Frequency = 77 MHz		26	59	mW
P <sub>OFFSET</sub>	Power at V <sub>OFFSET</sub> = 8.75 V <sup>(5)</sup>			5	13	mW
P <sub>BIAS</sub>	Power at V <sub>BIAS</sub> = 16.5 V <sup>(5)</sup>	3 Global Resets within time period = 200 μs		9	22	mW
P <sub>RESET</sub>	Power at V <sub>RESET</sub> = -10.5 V <sup>(5)</sup>	3 Global Resets within time period = 200 μs		4	13	mW
P <sub>TOTAL</sub>	Supply power dissipation Total			44	107	mW
<b>CAPACITANCE</b>						
C <sub>IN</sub>	Input Capacitance	f = 1 MHz			10	pF
C <sub>OUT</sub>	Output Capacitance	f = 1 MHz			10	pF

- (1) Includes LVCMOS pins only.  
(2) LVCMOS input pins do not have Pull-up or Pull-down configurations.  
(3) To prevent excess current, the supply voltage delta |V<sub>BIAS</sub> - V<sub>OFFSET</sub>| must be less than 8.75 V.  
(4) When DRC\_OEZ = High, the internal reset drivers are tri-stated and I<sub>BIAS</sub> standby current is 3.8 mA.  
(5) Nominal values are measured with V<sub>CC</sub> = 1.8 V, V<sub>OFFSET</sub> = 8.5 V, V<sub>BIAS</sub> = 16 V, and V<sub>RESET</sub> = -10 V.

## 6.7 Timing Requirements

			MIN	NOM	MAX	UNIT
$t_r$	Rise time <sup>(1)</sup>	20% to 80% DCLK			2.5	ns
$t_f$	Fall time <sup>(1)</sup>	80% to 20% DCLK			2.5	ns
$t_r$	Rise time <sup>(2)</sup>	20% to 80% DATA(11:0), SCTRL, LOADB			2.5	ns
$t_f$	Fall time <sup>(2)</sup>	80% to 20% DATA(11:0), SCTRL, LOADB			2.5	ns
$t_c$	Cycle time <sup>(1)</sup>	50% to 50% DCLK	12.5		16.67	ns
$t_w$	Pulse duration <sup>(1)</sup>	50% to 50% DCLK	5			ns
$t_w$	Pulse duration low <sup>(1)</sup>	50% to 50% LOADB	7			ns
$t_w$	Pulse duration high <sup>(1)</sup>	50% to 50% DRC_STROBE	7			ns
$t_{su}$	Setup time <sup>(1)</sup>	DATA(11:0) before rising or falling edge of DCLK	1			ns
$t_{su}$	Setup time <sup>(1)</sup>	SCTRL before rising or falling edge of DCLK	1			ns
$t_{su}$	Setup time <sup>(1)</sup>	LOADB low before rising edge of DCLK	1			ns
$t_{su}$	Setup time <sup>(2)</sup>	SAC_BUS low before rising edge of DCLK	2			ns
$t_{su}$	Setup time <sup>(2)</sup>	DRC_BUS high before rising edge of DCLK	2			ns
$t_{su}$	Setup time <sup>(1)</sup>	DRC_STROBE high before rising edge of DCLK	2			ns
$t_h$	Hold time <sup>(1)</sup>	DATA(11:0) after rising or falling edge of DCLK	1			ns
$t_h$	Hold time <sup>(1)</sup>	SCTRL after rising or falling edge of DCLK	1			ns
$t_h$	Hold time <sup>(1)</sup>	LOADB low after falling edge of DCLK	1			ns
$t_h$	Hold time <sup>(2)</sup>	SAC_BUS low after rising edge of DCLK	2			ns
$t_h$	Hold time <sup>(2)</sup>	DRC_BUS after rising edge of DCLK	2			ns
$t_h$	Hold time <sup>(1)</sup>	DRC_STROBE after rising edge of DCLK	2			ns

(1) Refer to [Figure 2](#) and [Figure 3](#).

(2) Refer to [Figure 4](#) and [Figure 5](#).

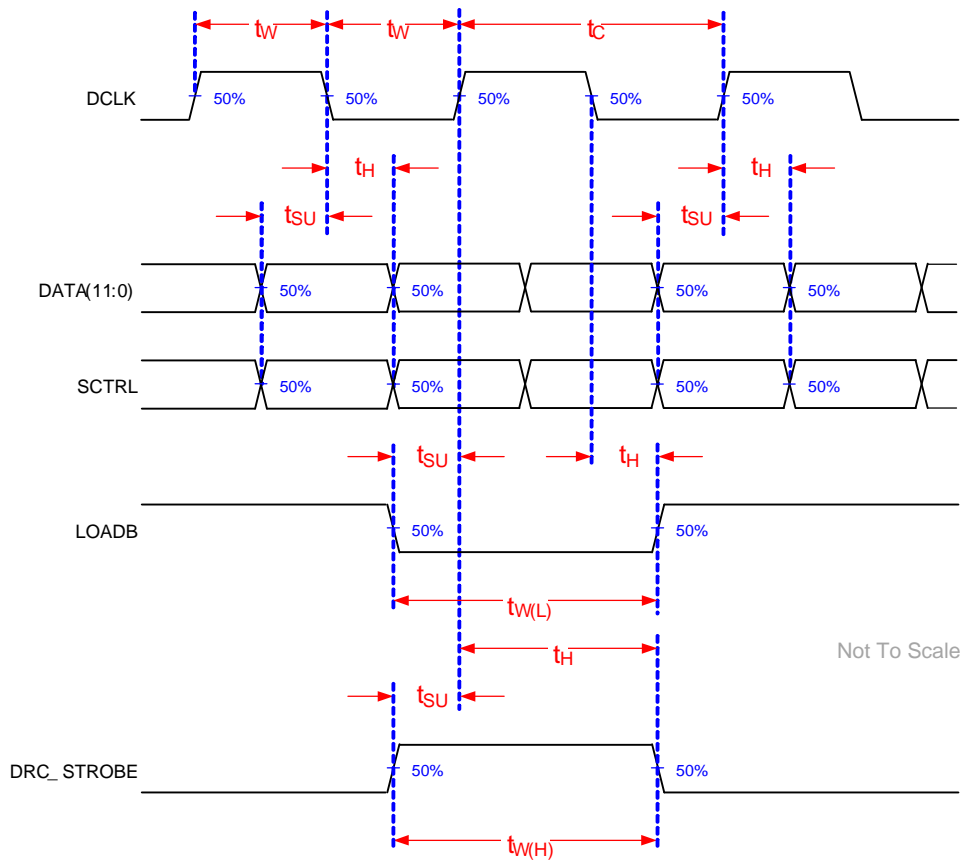

Figure 2. Switching Parameters 1

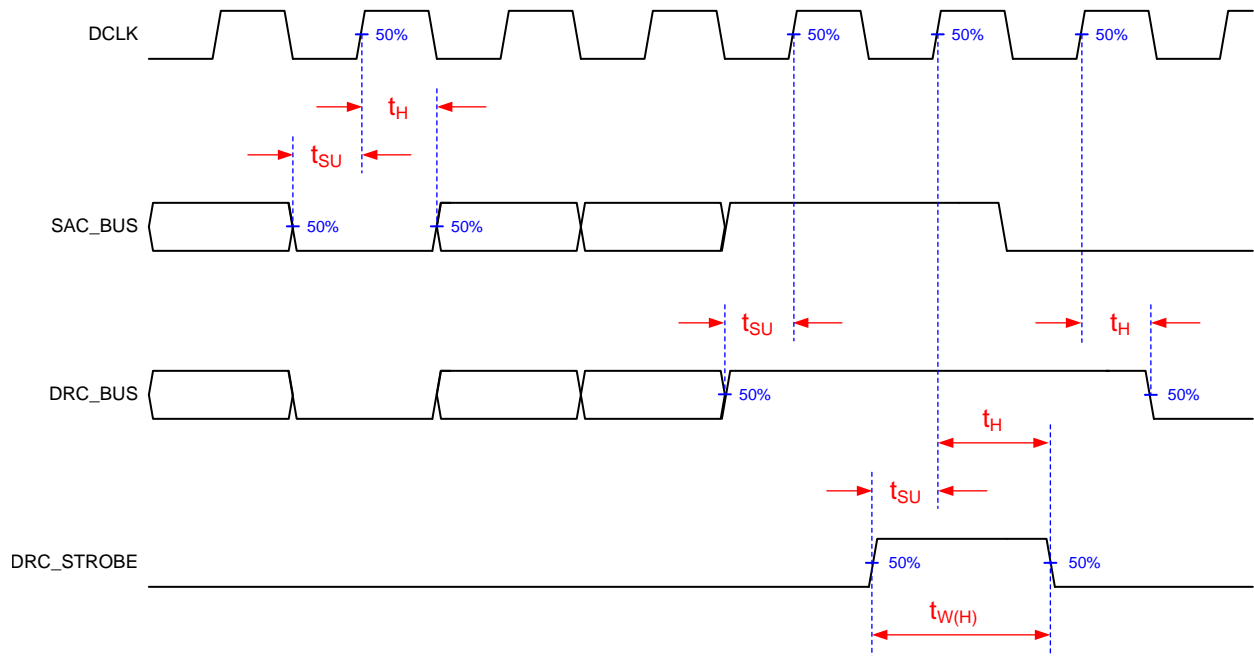

Figure 3. Switching Parameters 2

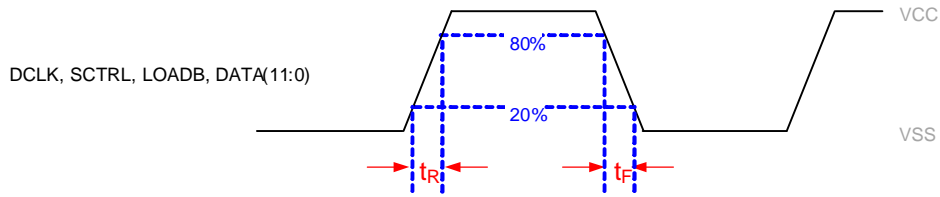

Figure 4. Rise and Fall Timing Parameters 1

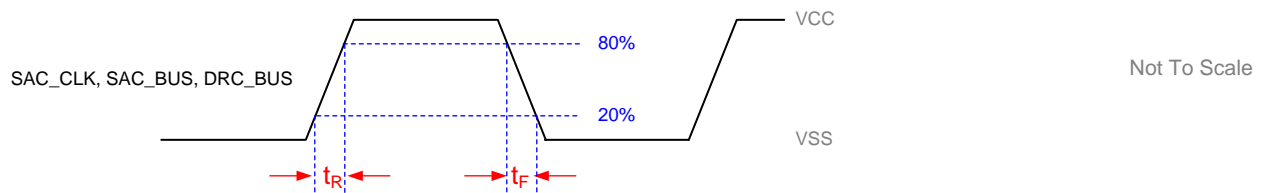

Figure 5. Rise and Fall Timing Parameters 2

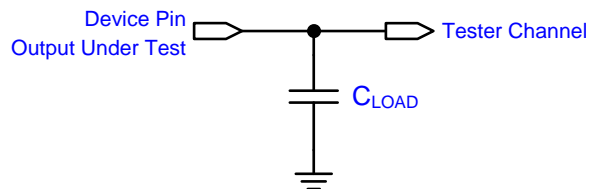

Figure 6. Test Load Circuit

See [Timing](#) for more information.

### 6.8 System Mounting Interface Loads

over operating free-air temperature range (unless otherwise noted)

PARAMETER		MIN	NOM	MAX	UNIT
Maximum system mounting interface load to be applied to the:	Connector area (see <a href="#">Figure 7</a> )			45	N
	DMD mounting area uniformly distributed over 4 areas (see <a href="#">Figure 7</a> )			100	N

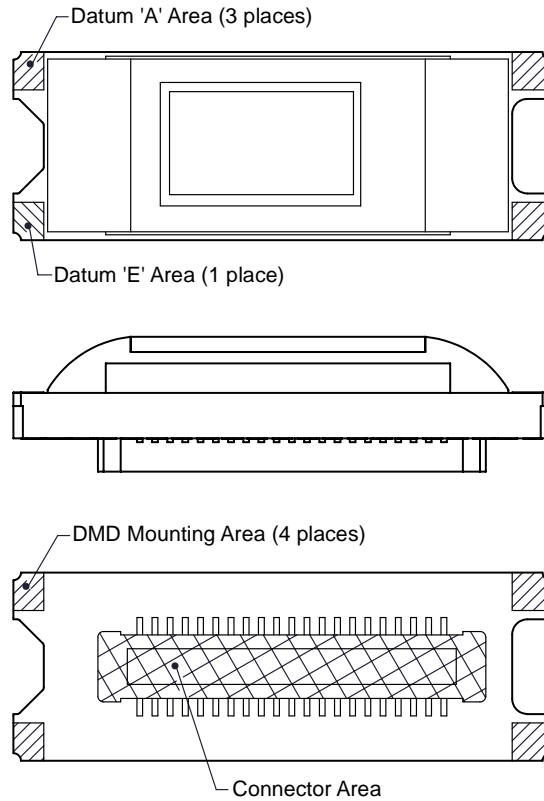
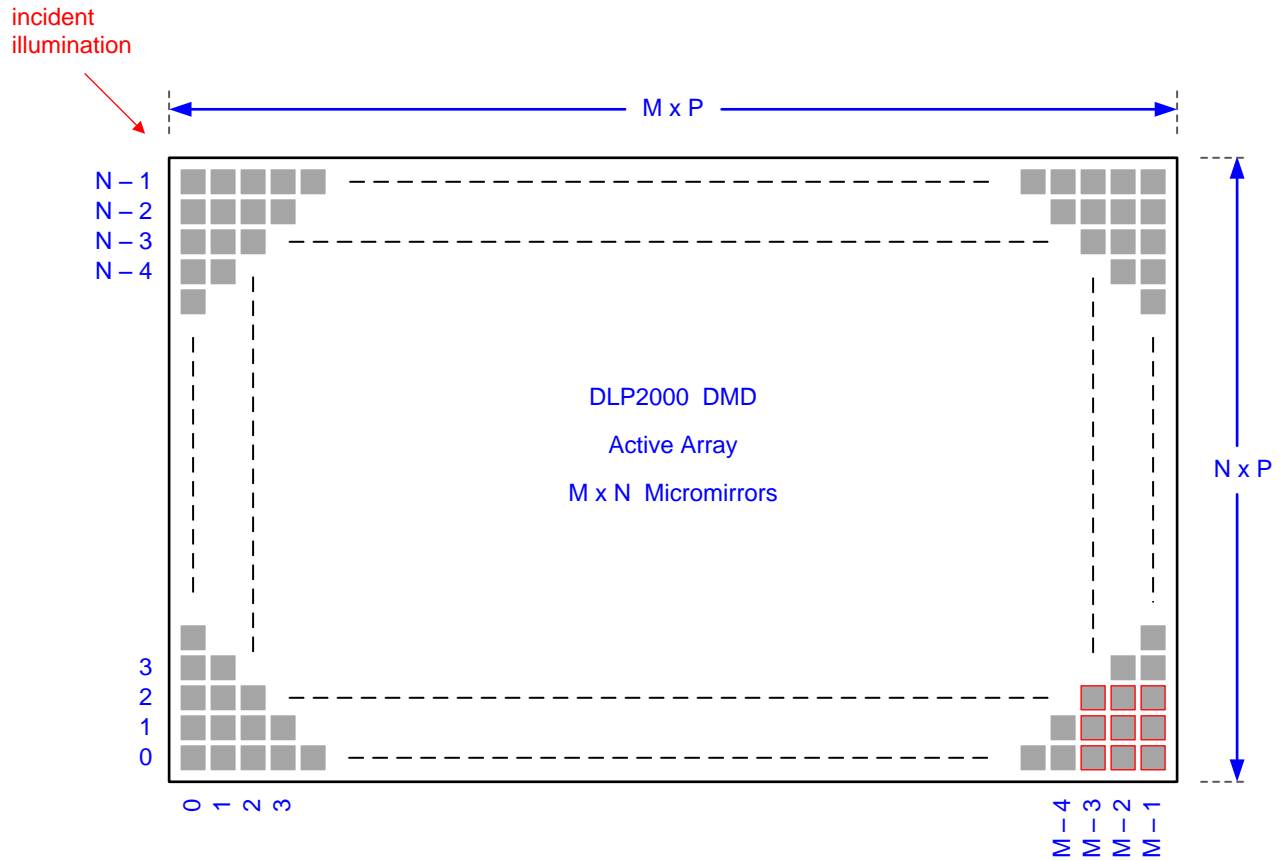

**Figure 7. System Interface Loads**

## 6.9 Physical Characteristics of the Micromirror Array

PARAMETER			VALUE	UNIT
M	Number of active columns <sup>(1)</sup>	See <a href="#">Figure 8</a>	640	micromirrors
N	Number of active rows <sup>(1)</sup>	See <a href="#">Figure 8</a>	360	micromirrors
P	Micromirror (pixel) pitch <sup>(1)</sup>	See <a href="#">Figure 8</a>	7.56	μm
	Micromirror active array width <sup>(1)</sup>	M × P	4.8384	mm
	Micromirror active array height <sup>(1)</sup>	N × P	2.7216	mm
	Micromirror active border <sup>(2)(3)</sup>	Pond of Micromirrors (POM)	8	micromirrors / side

- (1) See [Figure 8](#).
- (2) The structure and qualities of the border around the active array include a band of partially functional micromirrors called the “Pond of Micromirrors” (POM). These micromirrors are structurally and/or electrically prevented from tilting toward the bright or “on” state but still require an electrical bias to tilt toward “off.”
- (3) Out of the 8 POM rows on the top and bottom, only the 1 POM row closest to the active array is electrically attached to that reset group. The other 7 POM rows are attached to a dedicated POM internal reset driver circuit.



Pond Of Micromirrors (POM) omitted for clarity.  
 Details omitted for clarity.  
 Not to scale.

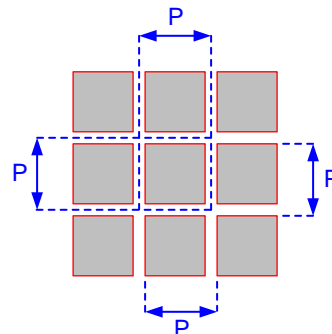

**Figure 8. Micromirror Array Physical Characteristics**

### 6.10 Micromirror Array Optical Characteristics

PARAMETER	MIN	NOM	MAX	UNIT
Micromirror Tilt - half angle, variation device to device <sup>(1)</sup>	11	12	13	degree
Axis of Rotation with respect to system datums, variation device to device <sup>(2)</sup>	44	45	46	degree

- (1) Limits on variability of micromirror tilt half angle are critical in the design of the accompanying optical system. Variations in tilt angle within a device may result in apparent non-uniformities, such as line pairing and image mottling, across the projected image. Variations in the average tilt angle between devices may result in colorimetry and system contrast variations. The specified limits represent the tolerances of the tilt angles within a device.
- (2) See Figure 9.

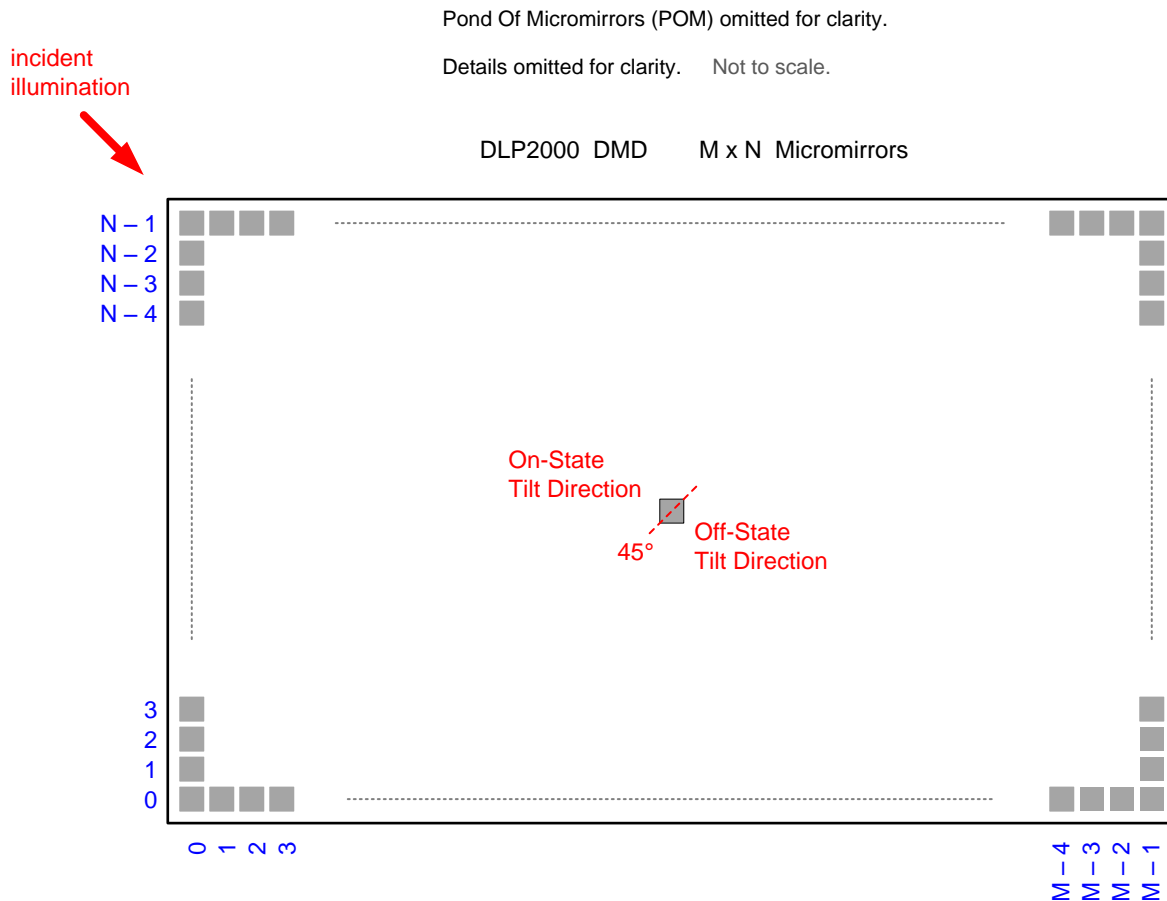

Figure 9. Landed Pixel Orientation and Tilt

See *Physical Characteristics of the Micromirror Array* for M and N specifications.

### 6.11 Window Characteristics

Table 1. DMD Window Characteristics

PARAMETER	VALUE	UNIT
Window Material	Corning Eagle XG	
Window Refractive Index at wavelength 546.1 nm	1.5119	
Window Transmittance, minimum within the wavelength range 420–680 nm. Applies to all angles 0–30° AOI. <sup>(1)(2)</sup>	97%	
Window Transmittance, average over the wavelength range 420–680 nm. Applies to all angles 30–45° AOI. <sup>(1)(2)</sup>	97%	

- (1) Single-pass through both surfaces and glass.
- (2) AOI – Angle Of Incidence is the angle between an incident ray and the normal of a reflecting or refracting surface.

## 6.12 Chipset Component Usage Specification

---

### NOTE

TI assumes no responsibility for image quality artifacts or DMD failures caused by optical system operating conditions exceeding limits described previously.

---

The DLP2000 is a component of one or more DLP chipsets. Reliable function and operation of the DLP2000 requires that it be used in conjunction with the other components of the applicable DLP chipset, including those components that contain or implement TI DMD control technology. TI DMD control technology is the TI technology and devices for operating or controlling a DLP DMD.



## 7 Detailed Description

### 7.1 Overview

The DLP2000 is a 0.2-inch diagonal spatial light modulator of aluminum micromirrors. Pixel array size is 640 columns by 360 rows in a square grid pixel arrangement. The DMD is an electrical input, optical output micro-electrical-mechanical system (MEMS). The electrical interface is a Double Data Rate (DDR) input data bus.

The DLP2000 is part of the chipset that includes the DLP2000 DMD, the DLPC2607 display controller, and the DLPA1000 PMIC/LED driver. To ensure optimal performance, the DLP2000 DMD should be used with the DLPC2607 display controller and the DLPA1000 PMIC/LED driver.

### 7.2 Functional Block Diagram

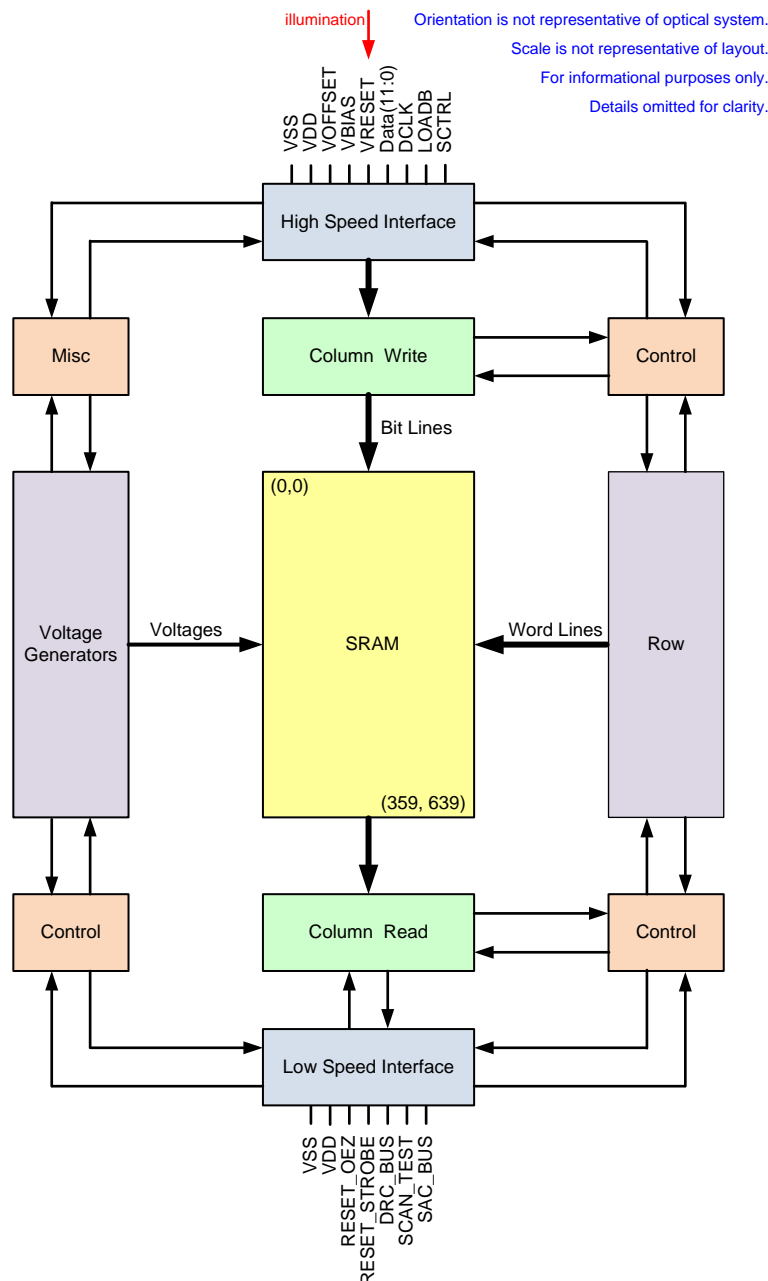

## 7.3 Feature Description

### 7.3.1 Power Interface

For the DLP2000 DMD, the power management IC is the DLPA1000. This driver contains three regulated DC supplies for the DMD reset circuitry:  $V_{BIAS}$ ,  $V_{RESET}$ , and  $V_{OFFSET}$ .

### 7.3.2 Control Serial Interface

The control serial interface handles instructions that configure the DMD and control reset operation. DRC\_BUS is the reset control serial bus, DRC\_OEZ is the active low, output enable signal for internal reset driver circuitry, DRC\_STROBE rising edge latches in the control signals, and SAC\_BUS is the stepped address control serial bus.

### 7.3.3 High Speed Interface

The purpose of the high-speed interface is to transfer pixel data rapidly and efficiently, making use of high speed DDR transfer and compression techniques to save power and time. The high speed interface is composed of LVCMOS signal receivers for inputs and a dedicated clock.

### 7.3.4 Timing

The data sheet provides timing at the device pin. For output timing analysis, the tester pin electronics and its transmission line effects must be taken into account. [Figure 6](#) shows an equivalent test load circuit for the output under test. The load capacitance value stated is only for characterization and measurement of AC timing signals. This load capacitance value does not indicate the maximum load the device is capable of driving.

Timing reference loads are not intended as a precise representation of any particular system environment or depiction of the actual load presented by a production test. System designers should use IBIS or other simulation tools to correlate the timing reference load to a system environment. Refer to the [Application and Implementation](#) section.

## 7.4 Device Functional Modes

DMD functional modes are controlled by the DLPC2607 controller. See the [DLPC2607 controller data sheet](#) or contact a TI applications engineer.

## 7.5 Window Characteristics and Optics

### 7.5.1 Optical Interface and System Image Quality

TI assumes no responsibility for end-equipment optical performance. Achieving the desired end-equipment optical performance involves making trade-offs between numerous components and system design parameters. Optimizing system optical performance and image quality strongly relates to optical system design parameter trades. Although it is not possible to anticipate every conceivable application, projector image quality and optical performance depends on compliance with the optical system operating conditions described in the following sections.

#### 7.5.1.1 Numerical Aperture and Stray Light Control

The angle defined by the numerical aperture of the illumination and projection optics at the DMD optical area should be the same. This angle should not exceed the nominal device mirror tilt angle unless appropriate apertures are added in the illumination and/or projection pupils to block out flat-state and stray light from the projection lens. The mirror tilt angle defines DMD capability to separate the "ON" optical path from any other light path, including undesirable flat-state specular reflections from the DMD window, DMD border structures, or other system surfaces near the DMD such as prism or lens surfaces. If the numerical aperture exceeds the mirror tilt angle, or if the projection numerical aperture angle is more than two degrees larger than the illumination numerical aperture angle, objectionable artifacts in the display's border and/or active area could occur.

## Window Characteristics and Optics (continued)

### 7.5.1.2 Pupil Match

TI's optical and image quality specifications assume that the exit pupil of the illumination optics is nominally centered within two degrees of the entrance pupil of the projection optics. Misalignment of pupils can create objectionable artifacts in the display's border as well as the active area, which may require additional system apertures to control, especially if the numerical aperture of the system exceeds the pixel tilt angle.

### 7.5.1.3 Illumination Overfill

The active area of the device is surrounded by an aperture on the inside DMD window surface that masks structures of the DMD chip assembly from normal view, and is sized to anticipate several optical operating conditions. Overfill light illuminating the area outside the active array can create artifacts from the mechanical features surrounding the active array and other surface anomalies that may be visible on the screen. The illumination optical system should be designed to limit light flux incident anywhere outside more than 20 pixels from the edge of the active array on all sides. Depending on the particular system's optical architecture and assembly tolerances, this amount of overfill light on the outside of the active array may still cause artifacts to still be visible.

## 7.6 Micromirror Array Temperature Calculation

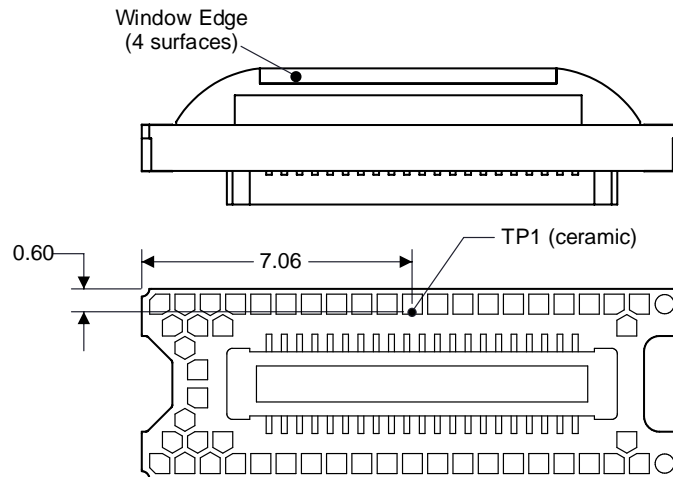

Figure 10. DMD Thermal Test Point

The micromirror array temperature can be computed analytically from measurement points on the outside of the package, the package thermal resistance, the electrical power dissipation, and the illumination heat load. The relationship between array temperature and the reference ceramic temperature is provided by the following equations:

$$T_{\text{ARRAY}} = T_{\text{CERAMIC}} + (Q_{\text{ARRAY}} \times R_{\text{ARRAY-TO-CERAMIC}}) \quad (1)$$

$$Q_{\text{ARRAY}} = Q_{\text{ELECTRICAL}} + Q_{\text{ILLUMINATION}} \quad (2)$$

$$Q_{\text{ILLUMINATION}} = (C_{\text{L2W}} \times \text{SL})$$

- $T_{\text{ARRAY}}$  = Computed DMD array temperature (°C)
- $T_{\text{CERAMIC}}$  = Measured ceramic temperature (°C), TP1 location in [Figure 10](#)
- $R_{\text{ARRAY-TO-CERAMIC}}$  = DMD package thermal resistance from array to outside ceramic (°C/W), specified in [Thermal Information](#)
- $Q_{\text{ARRAY}}$  = Total DMD power; electrical plus absorbed (calculated) (W)
- $Q_{\text{ELECTRICAL}}$  = Nominal DMD electrical power dissipation (W)
- $C_{\text{L2W}}$  = Conversion constant for screen lumens to absorbed optical power on the DMD (W/lm)
- $\text{SL}$  = Measured ANSI screen lumens (lm)

(3)

## Micromirror Array Temperature Calculation (continued)

The electrical power dissipation of the DMD is variable and depends on the voltages, data rates, and operating frequencies. A nominal electrical power dissipation to use when calculating array temperature is 0.045 watts. The absorbed power from the illumination source is variable and depends on the operating state of the mirrors and the intensity of the light source. The equations shown previously are valid for a 1-Chip DMD system with a total projection efficiency from DMD to screen of 87%.

The conversion constant  $C_{L2W}$  is based on DMD micromirror array characteristics. It assumes a spectral efficiency of 300 lumens/watt for the projected light, and an illumination distribution of 83.7% on the DMD active array and 16.3% on the DMD array border and window aperture. The conversion constant is calculated to be 0.00293 W/lm.

The following is a sample calculation for a typical projection application:

- $SL = 20 \text{ lm}$
- $T_{\text{Ceramic}} = 55^{\circ}\text{C}$
- $Q_{\text{Array}} = Q_{\text{ELECTRICAL}} + Q_{\text{ILLUMINATION}} = 0.045 \text{ W} + (0.00293 \text{ W/lm} \times 20 \text{ lm}) = 0.1036 \text{ W}$
- $T_{\text{Array}} = 55^{\circ}\text{C} + (0.1036 \text{ W} \times 8^{\circ}\text{C/W}) = 55.8^{\circ}\text{C}$

## 7.7 Micromirror Landed-On/Landed-Off Duty Cycle

### 7.7.1 Definition of Micromirror Landed-On/Landed-Off Duty Cycle

The micromirror landed-on/landed-off duty cycle (landed duty cycle) denotes the amount of time (as a percentage) that an individual micromirror is landed in the On state versus the amount of time the same micromirror is landed in the Off state.

As an example, a landed duty cycle of 75/25 indicates that the referenced pixel is in the On state 75% of the time (and in the Off state 25% of the time), whereas 25/75 would indicate that the pixel is in the On state 25% of the time. Likewise, 50/50 indicates that the pixel is On 50% of the time and Off 50% of the time.

Note that when assessing landed duty cycle, the time spent switching from one state (ON or OFF) to the other state (OFF or ON) is considered negligible and is thus ignored.

Since a micromirror can only be landed in one state or the other (On or Off), the two numbers (percentages) always add to 100.

### 7.7.2 Landed Duty Cycle and Useful Life of the DMD

Knowing the long-term average landed duty cycle (of the end product or application) is important because subjecting all (or a portion) of the DMD's micromirror array (also called the active array) to an asymmetric landed duty cycle for a prolonged period of time can reduce the DMD's usable life.

Note that it is the symmetry/asymmetry of the landed duty cycle that is of relevance. The symmetry of the landed duty cycle is determined by how close the two numbers (percentages) are to being equal. For example, a landed duty cycle of 50/50 is perfectly symmetrical whereas a landed duty cycle of 100/0 or 0/100 is perfectly asymmetrical.

### 7.7.3 Landed Duty Cycle and Operational DMD Temperature

Operational DMD Temperature and Landed Duty Cycle interact to affect the DMD's usable life, and this interaction can be exploited to reduce the impact that an asymmetrical Landed Duty Cycle has on the DMD's usable life. This is quantified in the de-rating curve shown in [Figure 1](#). The importance of this curve is that:

- All points along this curve represent the same usable life.
- All points above this curve represent lower usable life (and the further away from the curve, the lower the usable life).
- All points below this curve represent higher usable life (and the further away from the curve, the higher the usable life).

In practice, this curve specifies the Maximum Operating DMD Temperature that the DMD should be operated at for a given long-term average Landed Duty Cycle.

## Micromirror Landed-On/Landed-Off Duty Cycle (continued)

### 7.7.4 Estimating the Long-Term Average Landed Duty Cycle of a Product or Application

During a given period of time, the Landed Duty Cycle of a given pixel follows from the image content being displayed by that pixel.

For example, in the simplest case, when displaying pure-white on a given pixel for a given time period, that pixel will experience a 100/0 Landed Duty Cycle during that time period. Likewise, when displaying pure-black, the pixel will experience a 0/100 Landed Duty Cycle.

Between the two extremes (ignoring for the moment color and any image processing that may be applied to an incoming image), the Landed Duty Cycle tracks one-to-one with the gray scale value, as shown in [Table 2](#).

**Table 2. Grayscale Value and Landed Duty Cycle**

Grayscale Value	Landed Duty Cycle
0%	0/100
10%	10/90
20%	20/80
30%	30/70
40%	40/60
50%	50/50
60%	60/40
70%	70/30
80%	80/20
90%	90/10
100%	100/0

Accounting for color rendition (but still ignoring image processing) requires knowing both the color intensity (from 0% to 100%) for each constituent primary color (red, green, and/or blue) for the given pixel as well as the color cycle time for each primary color, where “color cycle time” is the total percentage of the frame time that a given primary must be displayed in order to achieve the desired white point.

During a given period of time, the landed duty cycle of a given pixel can be calculated as follows:

$$\text{Landed Duty Cycle} = (\text{Red\_Cycle\_}\% \times \text{Red\_Scale\_Value}) + (\text{Green\_Cycle\_}\% \times \text{Green\_Scale\_Value}) + (\text{Blue\_Cycle\_}\% \times \text{Blue\_Scale\_Value})$$

where

- Red\_Cycle\_%, Green\_Cycle\_%, and Blue\_Cycle\_% represent the percentage of the frame time that Red, Green, and Blue are displayed (respectively) to achieve the desired white point. (4)

For example, assume that the red, green and blue color cycle times are 50%, 20%, and 30% respectively (in order to achieve the desired white point), then the Landed Duty Cycle for various combinations of red, green, blue color intensities would be as shown in [Table 3](#).

**Table 3. Example Landed Duty Cycle for Full-Color Pixels**

Red Cycle Percentage	Green Cycle Percentage	Blue Cycle Percentage
50%	20%	30%

Red Scale Value	Green Scale Value	Blue Scale Value	Landed Duty Cycle
0%	0%	0%	0/100
100%	0%	0%	50/50
0%	100%	0%	20/80
0%	0%	100%	30/70
12%	0%	0%	6/94
0%	35%	0%	7/93
0%	0%	60%	18/82
100%	100%	0%	70/30
0%	100%	100%	50/50
100%	0%	100%	80/20
12%	35%	0%	13/87
0%	35%	60%	25/75
12%	0%	60%	24/76
100%	100%	100%	100/0

## 8 Application and Implementation

### NOTE

Information in the following applications sections is not part of the TI component specification, and TI does not warrant its accuracy or completeness. TI's customers are responsible for determining suitability of components for their purposes. Customers should validate and test their design implementation to confirm system functionality.

### 8.1 Application Information

The DMDs are spatial light modulators which reflect incoming light from an illumination source to one of two directions, with the primary direction being into projection or collection optics. Each application is derived primarily from the optical architecture of the system and the format of the data coming into the the DLPC2607 controller. Applications of interest include internet of things (IoT) devices such as control panels, and security systems and thermostats, as well as projection embedded in display applications like smartphones, tablets, cameras, and artificial intelligence (AI) assistance. Other applications include wearable (near-eye) displays, micro digital signage, and ultra-low power smart accessory projectors.

DMD power-up and power-down sequencing is strictly controlled by the DLPA1000. Refer to the [Power Supply Recommendations](#) for power-up and power-down specifications. The DLP2000 DMD reliability is only specified when used with the DLPC2607 controller and the DLPA1000 PMIC/LED Driver.

### 8.2 Typical Application

A common application for the DLP2000 chipset is creating a pico-projector embedded in a handheld product. For example, a pico-projector embedded in a smart phone, camera, battery powered mobile accessory, micro digital signage or IoT application. The DLPC2607 controller in the pico-projector receives images from a multimedia front end within the product as shown in [Figure 11](#).

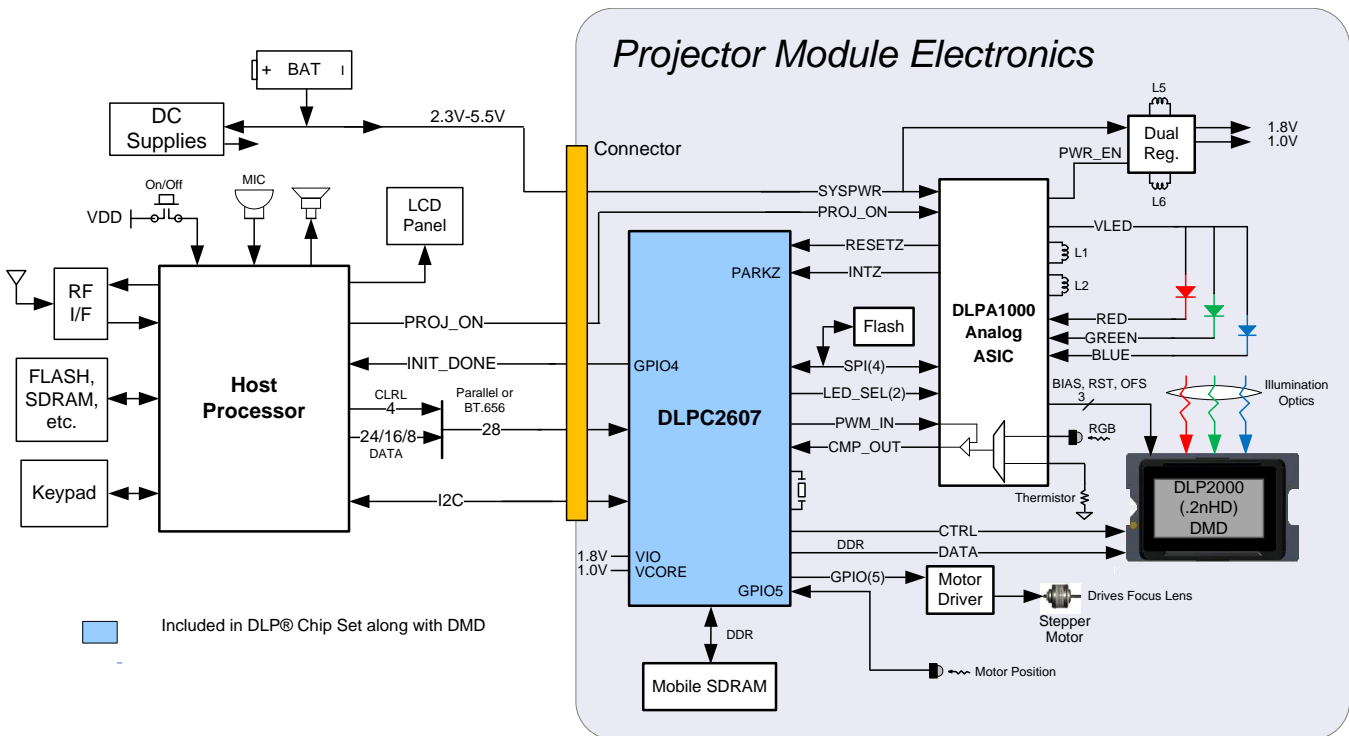

Figure 11. Block Diagram

## Typical Application (continued)

### 8.2.1 Design Requirements

A pico-projector is created by using a DLP chip set comprised of the DLP2000 DMD, a DLPC2607 controller, and a DLPA1000 PMIC/LED driver. The DLPC2607 controller does the digital image processing, the DLPA1000 provides the needed analog functions for the projector, and the DLP2000 DMD is the display device producing the projected image.

In addition to the three DLP chips in the chipset, other chips may be needed. This includes a Flash part needed to store the software and firmware for controlling the DLPC2607 controller.

The illumination that is applied to the DMD is typically from red, green, and blue LEDs. These are often contained in three separate packages, but sometimes more than one color of LED die may be in the same package to reduce the overall size of the pico-projector.

When connecting the DLPC2607 controller to the multimedia front end to receive images, a parallel interface is used. When using the parallel interface, the I<sup>2</sup>C should be connected to the multimedia front end to send commands to the DLPC2607 controller and configure the DLPC2607 controller for different features.

### 8.2.2 Detailed Design Procedure

To connect the DLPC2607 controller, the DLPA1000, and the DLP2000 DMD, see the reference design schematic. A small circuit board layout is possible when using this schematic. An example small board layout is included in the reference design data base. Layout guidelines should be followed to achieve a reliable projector. An optical OEM who specializes in designing optics for DLP projectors typically supplies the optical engine that has the LED packages and the DMD mounted on it.

### 8.2.3 Application Curves

As the LED currents that are driven time-sequentially through the red, green, and blue LEDs are increased, the brightness of the projector increases. This increase is somewhat non-linear, and the curve for typical white screen lumens changes with LED currents is as shown in Figure 12. For the LED currents shown, it is assumed that the same current amplitude is applied to the red, green, and blue LEDs.

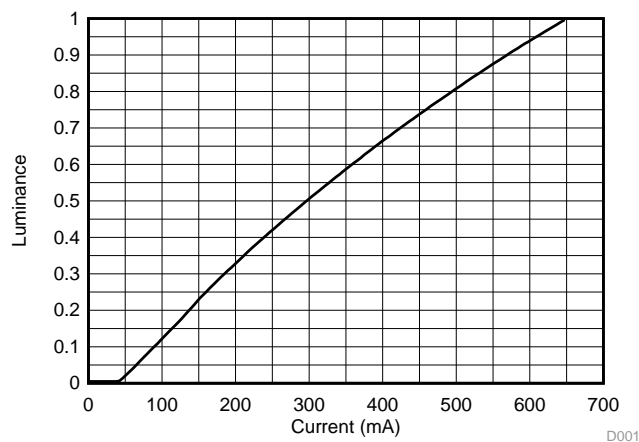

**Figure 12. Luminance vs Current**



## 9 Power Supply Recommendations

The following power supplies are all required to operate the DMD:  $V_{SS}$ ,  $V_{CC}$ ,  $V_{OFFSET}$ ,  $V_{BIAS}$ , and  $V_{RESET}$ . DMD power-up and power-down sequencing is strictly controlled by the DLPA1000 device.

$V_{CC}$ ,  $V_{OFFSET}$ ,  $V_{BIAS}$ , and  $V_{RESET}$  power supplies have to be coordinated during power-up and power-down operations. Failure to meet any of the following requirements will result in a significant reduction in the DMD's reliability and lifetime. Refer to [Figure 13](#).

### CAUTION

For reliable operation of the DMD, the following power supply sequencing requirements must be followed. Failure to adhere to the prescribed power-up and power-down procedures may affect device reliability.

$V_{CC}$ ,  $V_{OFFSET}$ ,  $V_{BIAS}$ , and  $V_{RESET}$  power supplies have to be coordinated during power-up and power-down operations. Failure to meet any of the following requirements will result in a significant reduction in the DMD's reliability and lifetime.

### 9.1 Power Supply Power-Up Procedure

- During Power-Up,  $V_{CC}$  must always start and settle before  $V_{OFFSET}$ ,  $V_{BIAS}$ , and  $V_{RESET}$  voltages are applied to the DMD.
- During Power-Up,  $V_{BIAS}$  does not have to start after  $V_{OFFSET}$ . However, it is a strict requirement that the delta between  $V_{BIAS}$  and  $V_{OFFSET}$  must be within  $\pm 8.75$  V (Note 1).
- During Power-Up, the DMD's LVCMOS input pins shall not be driven high until after  $V_{CC}$  has settled at operating voltage.
- During Power-Up, there is no requirement for the relative timing of  $V_{RESET}$  with respect to  $V_{OFFSET}$  and  $V_{BIAS}$ .
- Slew Rates for Power-Up are flexible, as long as the transient voltage levels follow the requirements listed previously.

### 9.2 Power Supply Power-Down Procedure

- Power-Down sequence is the reverse order of the previous Power-Up sequence.  $V_{CC}$  must be supplied until after  $V_{BIAS}$ ,  $V_{RESET}$  and  $V_{OFFSET}$  are discharged to within 4 V of ground.
- During Power-Down, it is not mandatory to stop driving  $V_{BIAS}$  prior to  $V_{OFFSET}$ , but it is a strict requirement that the delta between  $V_{BIAS}$  and  $V_{OFFSET}$  must be within  $\pm 8.75$  V (Note 1).
- During Power-Down, the DMD's LVCMOS input pins must be less than  $V_{CC} + 0.3$  V.
- During Power-Down, there is no requirement for the relative timing of  $V_{RESET}$  with respect to  $V_{OFFSET}$  and  $V_{BIAS}$ .
- Slew Rates for Power-Down are flexible, as long as the transient voltage levels follow the requirements listed previously.

### Power Supply Power-Down Procedure (continued)

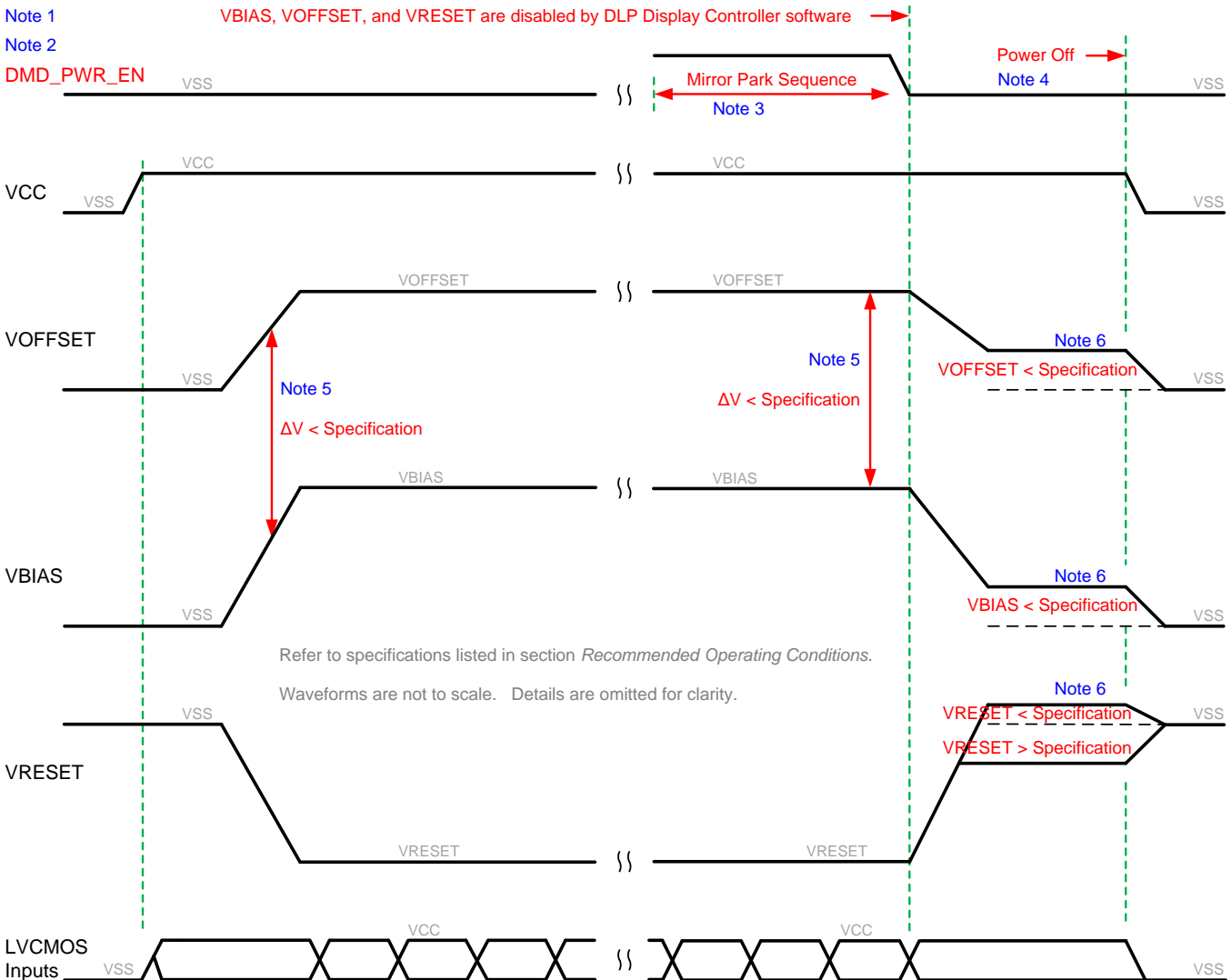

**Figure 13. DMD Power Supply Sequencing Requirements**

Note 1: Refer to specifications listed in the *Recommended Operating Conditions*. Waveforms are not to scale. Details are omitted for clarity.

Note 2: DMD\_PWR\_EN is not a package pin on the DMD. It is a signal from the DLP Display Controller (DLPC2607) that enables the  $V_{RESET}$ ,  $V_{BIAS}$ , and  $V_{OFFSET}$  regulators on the system board.

Note 3: After the DMD micromirror park sequence is complete, the DLP display controller (DLPC2607) software initiates a hardware power-down that disables  $V_{BIAS}$ ,  $V_{RESET}$  and  $V_{OFFSET}$ .

Note 4: During the micromirror parking process,  $V_{CC}$ ,  $V_{BIAS}$ ,  $V_{OFFSET}$ , and  $V_{RESET}$  power supplies are all required to be within the specification limits in the *Recommended Operating Conditions*. Once the micromirrors are parked,  $V_{BIAS}$ ,  $V_{OFFSET}$ , and  $V_{RESET}$  power supplies can be turned off.

Note 5: To prevent excess current, the supply voltage delta  $|V_{BIAS} - V_{OFFSET}|$  must be less than specified in the *Recommended Operating Conditions*. It is critical to meet this requirement and that  $V_{BIAS}$  not reach full power level until after  $V_{OFFSET}$  is at almost full power level. OEMs may find that the most reliable way to ensure this is to delay powering  $V_{BIAS}$  until after  $V_{OFFSET}$  is fully powered on during power-up (and to remove  $V_{BIAS}$  prior to  $V_{OFFSET}$  during power down). In this case,  $V_{OFFSET}$  is run at its maximum allowable voltage level (8.75 V).

Note 6: Refer to specifications listed in [Table 4](#).

**Power Supply Power-Down Procedure (continued)**
**Table 4. DMD Power-Down Sequence Requirements**

PARAMETER	DESCRIPTION	MIN	MAX	UNIT
V <sub>BIAS</sub>	Supply voltage level during power-down sequence		4.0	V
V <sub>OFFSET</sub>	Supply voltage level during power-down sequence		4.0	V
V <sub>RESET</sub>	Supply voltage level during power-down sequence	-4.0	0.5	V

## 10 Layout

### 10.1 Layout Guidelines

There are no specific layout guidelines for the DMD, however the DMD is typically connected using a board to board connector with a flex cable. The flex cable provides an interface for data and control signals between the DLPC2607 controller and the DLP2000 DMD. For detailed layout guidelines refer to the DLPC2607 controller layout guidelines under PCB design and DMD interface considerations.

Some layout guidelines for the flex cable interface with the DMD are:

- Minimize the number of layer changes for DMD data and control signals.
- DMD data and control lines are DDR, whereas DMD\_SAC and DMD\_DRC lines are single data rate. Matching the DDR lines is more critical and should take precedence over matching single data rate lines.
- [Figure 14](#) and [Figure 15](#) show the top and bottom layer of the DMD flex cable connections.

### 10.2 Layout Example

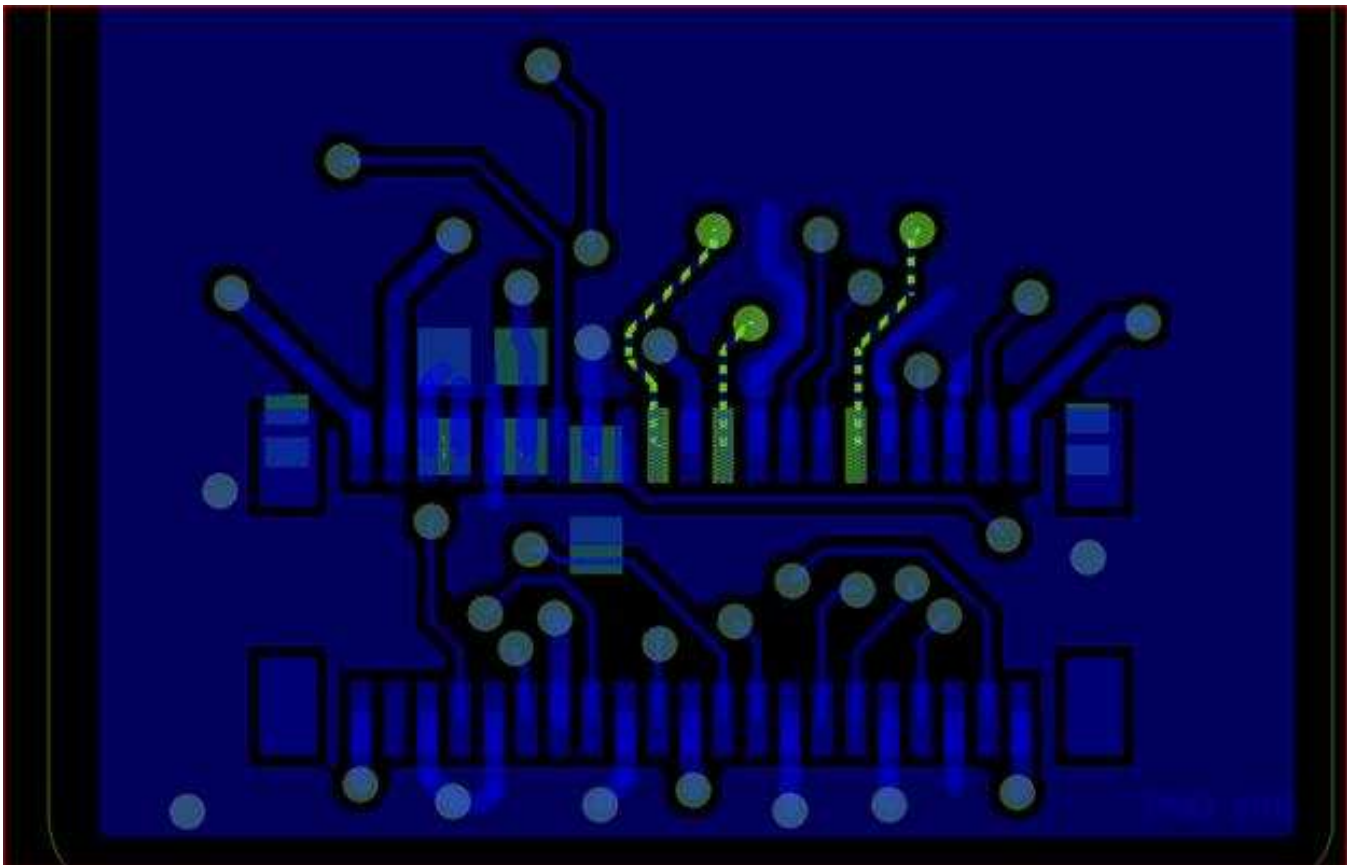

**Figure 14. DMD Flex Cable - Top Layer**

Layout Example (continued)

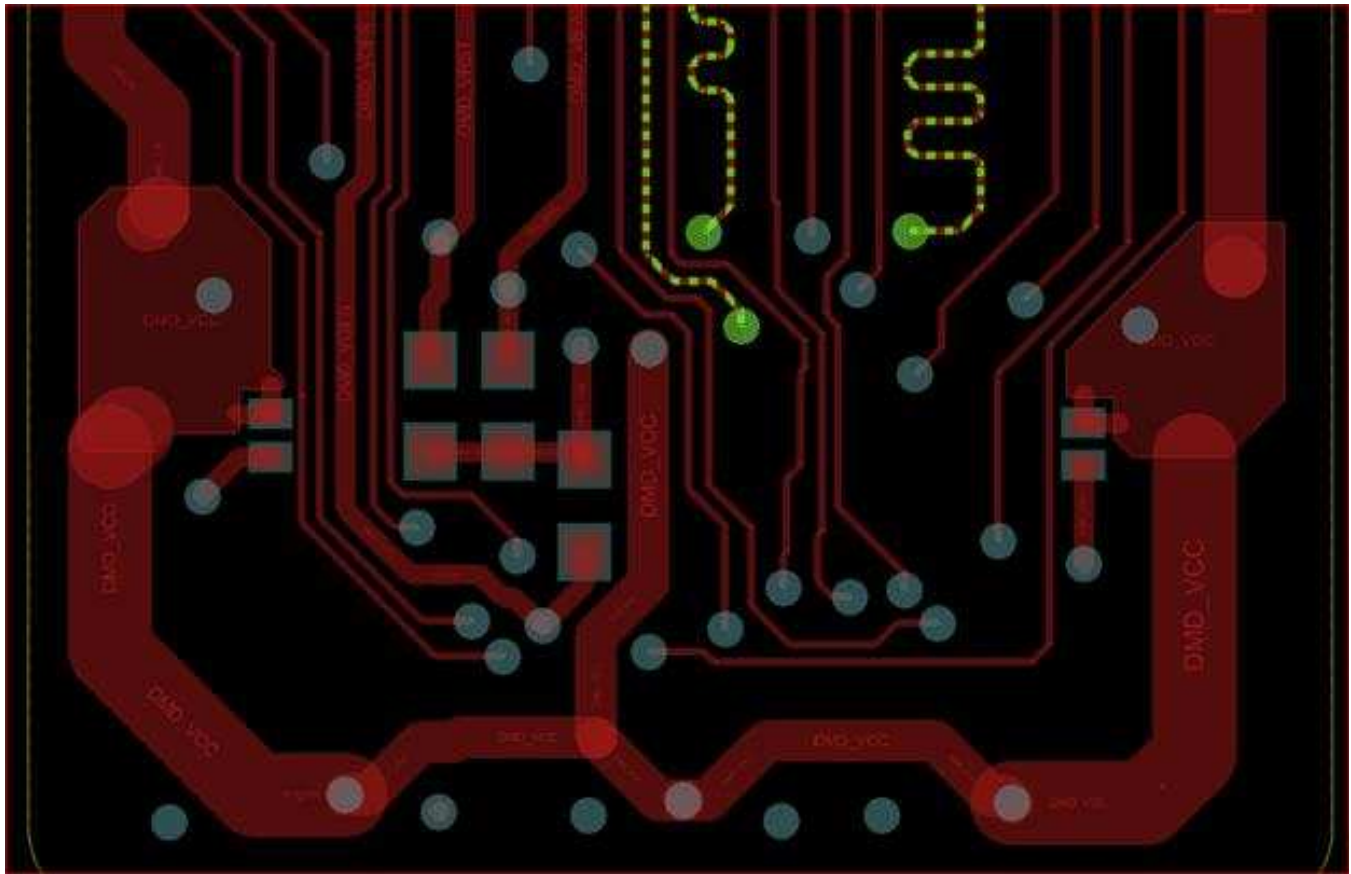

Figure 15. DMD Flex Cable - Bottom Layer

## 11 Device and Documentation Support

### 11.1 Device Support

#### 11.1.1 Device Nomenclature

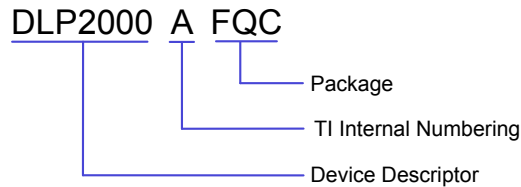

Figure 16. Part Number Description

#### 11.1.2 Device Markings

- Device Marking includes the Human-Readable character string GHJJJK VVVV
- GHJJJK is the Lot Trace Code
- VVVV is a 4 character Encoded Device Part Number

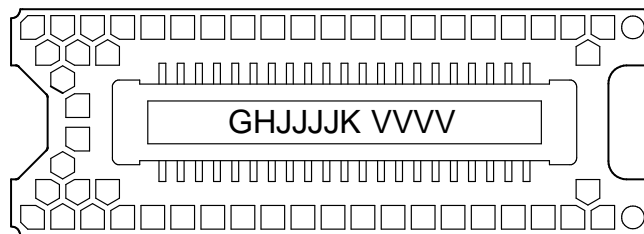

Figure 17. DMD Marking Location

## 11.2 Related Links

The table below lists quick access links. Categories include technical documents, support and community resources, tools and software, and quick access to sample or buy.

Table 5. Related Links

PARTS	PRODUCT FOLDER	SAMPLE & BUY	TECHNICAL DOCUMENTS	TOOLS & SOFTWARE	SUPPORT & COMMUNITY
DLPC2607	<a href="#">Click here</a>	<a href="#">Click here</a>	<a href="#">Click here</a>	<a href="#">Click here</a>	<a href="#">Click here</a>
DLPA1000	<a href="#">Click here</a>	<a href="#">Click here</a>	<a href="#">Click here</a>	<a href="#">Click here</a>	<a href="#">Click here</a>

## 11.3 Community Resources

The following links connect to TI community resources. Linked contents are provided "AS IS" by the respective contributors. They do not constitute TI specifications and do not necessarily reflect TI's views; see TI's [Terms of Use](#).

**TI E2E™ Online Community** *TI's Engineer-to-Engineer (E2E) Community*. Created to foster collaboration among engineers. At [e2e.ti.com](http://e2e.ti.com), you can ask questions, share knowledge, explore ideas and help solve problems with fellow engineers.

**Design Support** *TI's Design Support* Quickly find helpful E2E forums along with design support tools and contact information for technical support.

## 11.4 Trademarks

## 11.4 Trademarks (continued)

E2E is a trademark of Texas Instruments.

## 11.5 Electrostatic Discharge Caution



These devices have limited built-in ESD protection. The leads should be shorted together or the device placed in conductive foam during storage or handling to prevent electrostatic damage to the MOS gates.

## 11.6 Glossary

[SLYZ022](#) — *TI Glossary*.

This glossary lists and explains terms, acronyms, and definitions.

## 12 Mechanical, Packaging, and Orderable Information

The following pages include mechanical, packaging, and orderable information. This information is the most current data available for the designated devices. This data is subject to change without notice and revision of this document. For browser-based versions of this data sheet, refer to the left-hand navigation.



**PACKAGING INFORMATION**

Orderable Device	Status (1)	Package Type	Package Drawing	Pins	Package Qty	Eco Plan (2)	Lead/Ball Finish (6)	MSL Peak Temp (3)	Op Temp (°C)	Device Marking (4/5)	Samples
DLP2000AFQC	ACTIVE	CLGA	FQC	42	180	RoHS & Green	Call TI	N / A for Pkg Type	0 to 70		<a href="#">Samples</a>
DLP2000FQC	ACTIVE	CLGA	FQC	42		RoHS & Green			0 to 70		<a href="#">Samples</a>

(1) The marketing status values are defined as follows:

**ACTIVE:** Product device recommended for new designs.

**LIFEBUY:** TI has announced that the device will be discontinued, and a lifetime-buy period is in effect.

**NRND:** Not recommended for new designs. Device is in production to support existing customers, but TI does not recommend using this part in a new design.

**PREVIEW:** Device has been announced but is not in production. Samples may or may not be available.

**OBSOLETE:** TI has discontinued the production of the device.

(2) **RoHS:** TI defines "RoHS" to mean semiconductor products that are compliant with the current EU RoHS requirements for all 10 RoHS substances, including the requirement that RoHS substance do not exceed 0.1% by weight in homogeneous materials. Where designed to be soldered at high temperatures, "RoHS" products are suitable for use in specified lead-free processes. TI may reference these types of products as "Pb-Free".

**RoHS Exempt:** TI defines "RoHS Exempt" to mean products that contain lead but are compliant with EU RoHS pursuant to a specific EU RoHS exemption.

**Green:** TI defines "Green" to mean the content of Chlorine (Cl) and Bromine (Br) based flame retardants meet JS709B low halogen requirements of <=1000ppm threshold. Antimony trioxide based flame retardants must also meet the <=1000ppm threshold requirement.

(3) MSL, Peak Temp. - The Moisture Sensitivity Level rating according to the JEDEC industry standard classifications, and peak solder temperature.

(4) There may be additional marking, which relates to the logo, the lot trace code information, or the environmental category on the device.

(5) Multiple Device Markings will be inside parentheses. Only one Device Marking contained in parentheses and separated by a "~" will appear on a device. If a line is indented then it is a continuation of the previous line and the two combined represent the entire Device Marking for that device.

(6) Lead/Ball Finish - Orderable Devices may have multiple material finish options. Finish options are separated by a vertical ruled line. Lead/Ball Finish values may wrap to two lines if the finish value exceeds the maximum column width.

**Important Information and Disclaimer:**The information provided on this page represents TI's knowledge and belief as of the date that it is provided. TI bases its knowledge and belief on information provided by third parties, and makes no representation or warranty as to the accuracy of such information. Efforts are underway to better integrate information from third parties. TI has taken and continues to take reasonable steps to provide representative and accurate information but may not have conducted destructive testing or chemical analysis on incoming materials and chemicals. TI and TI suppliers consider certain information to be proprietary, and thus CAS numbers and other limited information may not be available for release.

In no event shall TI's liability arising out of such information exceed the total purchase price of the TI part(s) at issue in this document sold by TI to Customer on an annual basis.

© COPYRIGHT 2009 TEXAS INSTRUMENTS  
UN-PUBLISHED. ALL RIGHTS RESERVED.

REVISIONS			
REV	DESCRIPTION	DATE	BY
A	ECO 2100735 INITIAL RELEASE	8/3/09	BMH
B	ECO 2102356 ADD DATUM E AND NOTE 9; UPDATE SOLDER APPEARANCE; TIGHTEN NOTCH X-AXIS TOL'S	10/22/09	BMH
C	ECO 2104056 CHG ENCAP MAX HEIGHT FROM TBD TO ZERO	1/4/10	BMH
D	ECO 2166625 ADD "FQC PACKAGE" TO DRAWING TITLE; SHOW APERTURE CORNER RADII PICTORIALLY	5/30/17	BMH

- NOTES UNLESS OTHERWISE SPECIFIED:
- 1 DIE PARALLELISM TOLERANCE APPLIES TO DMD ACTIVE ARRAY ONLY.
  - 2 ROTATION ANGLE OF DMD ACTIVE ARRAY IS A REFINEMENT OF THE LOCATION TOLERANCE AND HAS A MAXIMUM ALLOWED VALUE OF 0.6 DEGREES.
  - 3 BOUNDARY MIRRORS SURROUNDING THE DMD ACTIVE ARRAY.
  - 4 DMD MARKING TO APPEAR IN CONNECTOR RECESS.
  - 5 NOTCH DIMENSIONS ARE DEFINED BY UPPERMOST LAYERS OF CERAMIC, AS SHOWN IN SECTION A-A.
  - 6 ENCAPSULANT TO BE CONTAINED WITHIN DIMENSIONS SHOWN IN VIEW C (SHEET 2). NO ENCAPSULANT IS ALLOWED ON TOP OF THE WINDOW.
  - 7 ENCAPSULANT NOT TO EXCEED THE HEIGHT OF THE WINDOW.
  - 8 DATUM B IS DEFINED BY A DIA. 2.5 PIN, WITH A FLAT ON THE SIDE FACING TOWARD THE CENTER OF THE ACTIVE ARRAY, AS SHOWN IN VIEW B (SHEET 2).
  - 9 WHILE ONLY THE THREE DATUM A TARGET AREAS A1, A2, AND A3 ARE USED FOR MEASUREMENT, ALL 4 CORNERS SHOULD BE CONTACTED, INCLUDING E1, TO SUPPORT MECHANICAL LOADS.

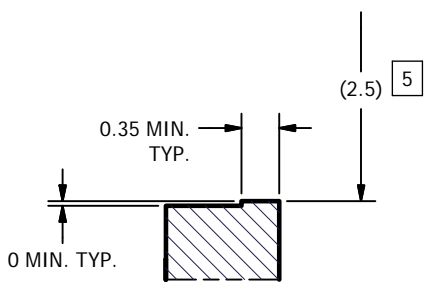
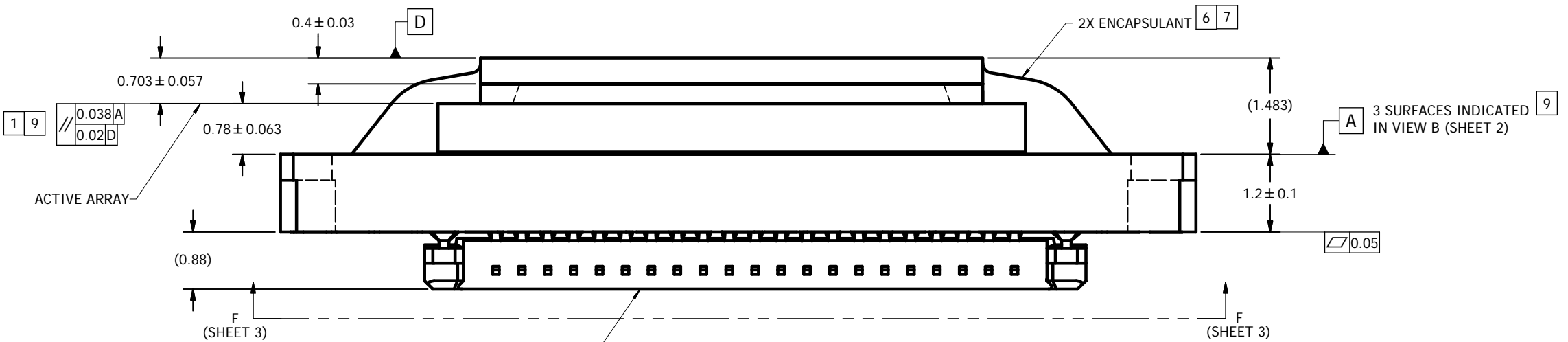
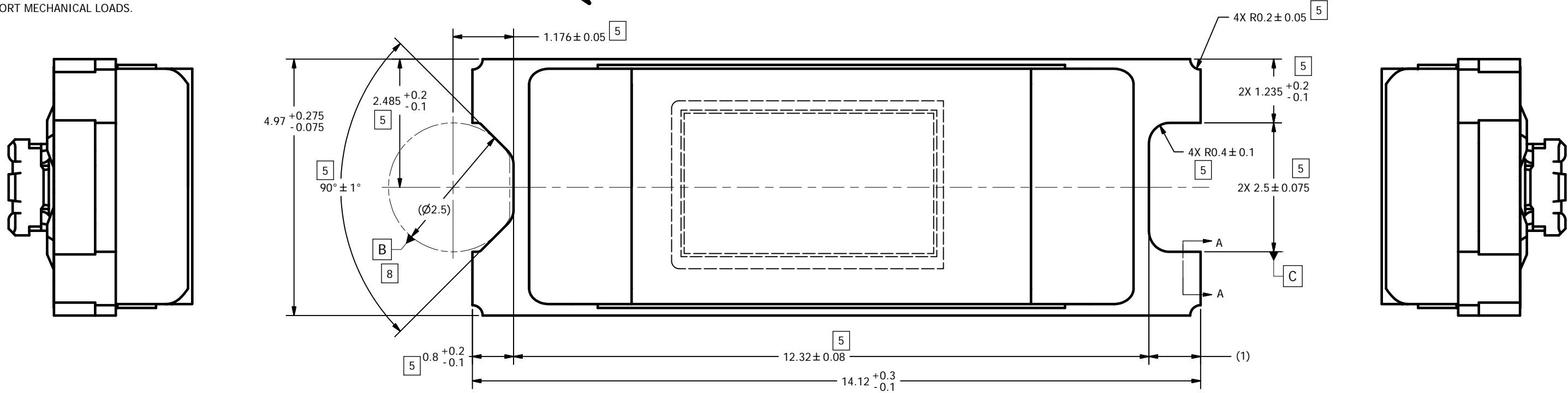

(PANASONIC AXT642124DD1, 42-CONTACT, 0.4 mm PITCH BOARD-TO-BOARD HEADER) INTERFACE TO PANASONIC AXT542124DD1 SOCKET

UNLESS OTHERWISE SPECIFIED	
● DIMENSIONS ARE IN MILLIMETERS	
● TOLERANCES:	
ANGLES ± 1°	
2 PLACE DECIMALS ± 0.25	
1 PLACE DECIMALS ± 0.50	
● DIMENSIONAL LIMITS APPLY BEFORE PROCESSES	
● INTERPRET DIMENSIONS IN ACCORDANCE WITH ASME Y14.5M-1994	
● REMOVE ALL BURRS AND SHARP EDGES	
● PARENTHETICAL INFORMATION FOR REFERENCE ONLY	
THIRD ANGLE PROJECTION	NONE
APPLICATION	0314DA
	NEXT ASSY USED ON

DRAWN	DATE
B. HASKETT	8/3/2009
ENGINEER	
B. HASKETT	8/3/2009
QA/CE	
P. KONRAD	8/3/2009
CM	
F. ARMSTRONG	8/3/2009
APPROVED	
J. GRIMMETT	8/3/2009

 <b>TEXAS INSTRUMENTS</b> <small>Dallas, Texas</small>	
<b>TITLE</b> ICD, MECHANICAL, DMD, .2 nHD DDR SERIES 230 (FQC PACKAGE)	
SIZE	D
DWG NO	2510560
REV	D
SCALE	25:1
SHEET	1 OF 3

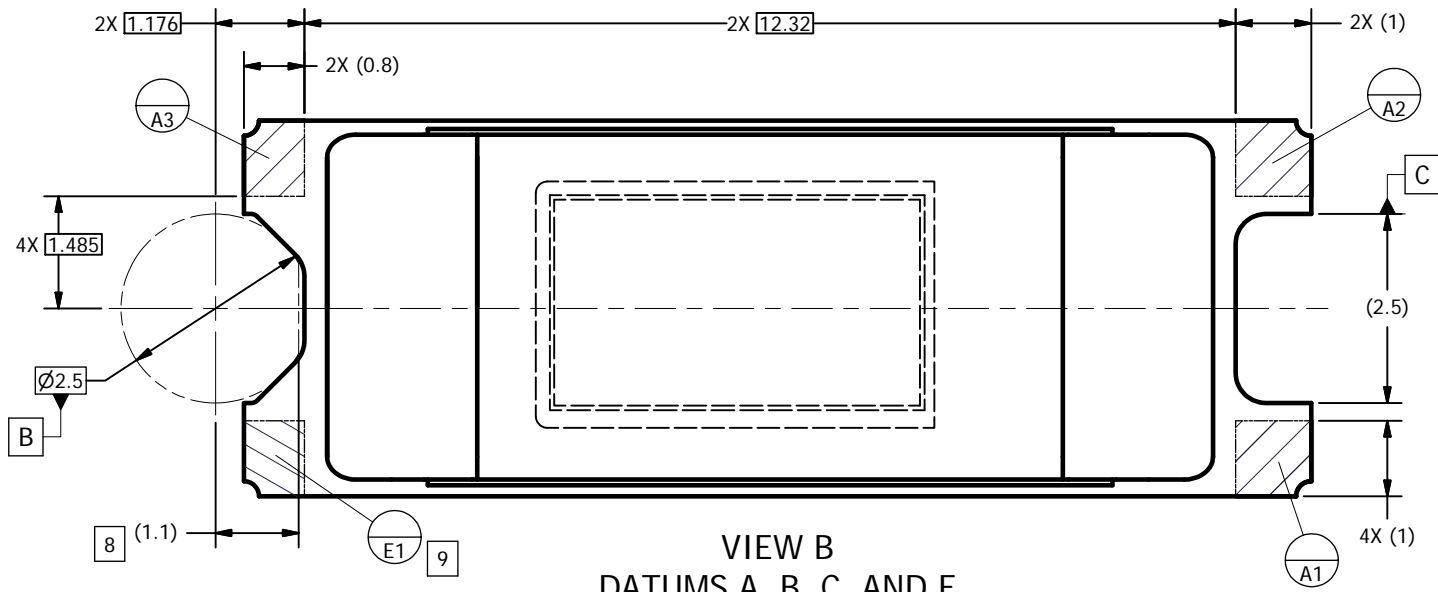

**VIEW B**  
 DATUMS A, B, C, AND E  
 SCALE 20 : 1  
 (FROM SHEET 1)

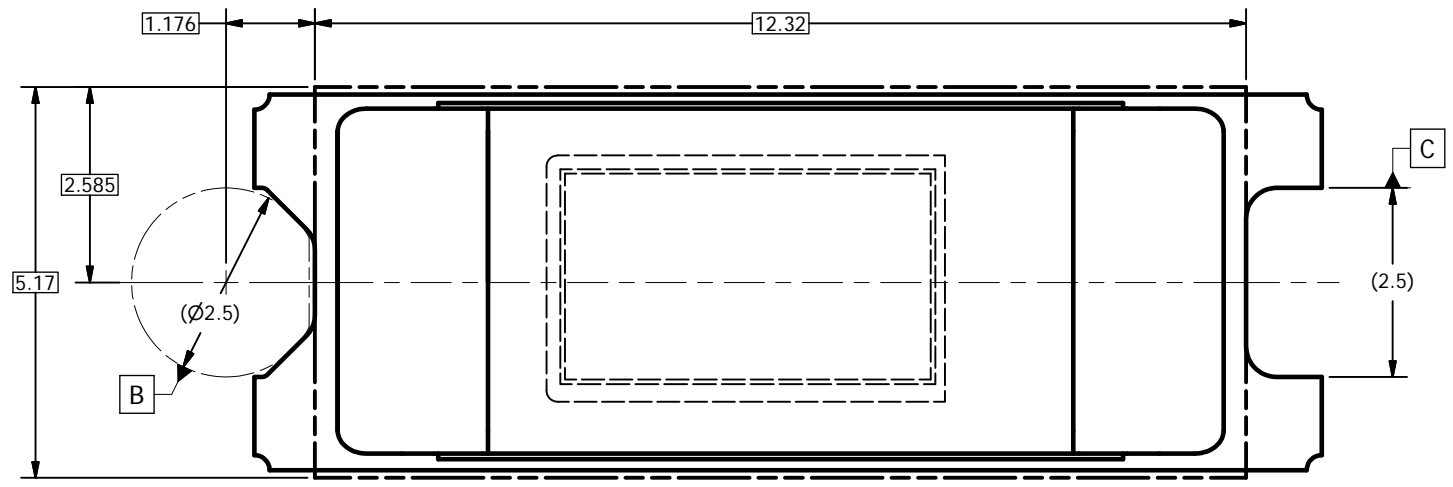

**VIEW C** 6  
 ENCAPSULANT MAXIMUM X/Y DIMENSIONS  
 SCALE 20 : 1  
 (FROM SHEET 1)

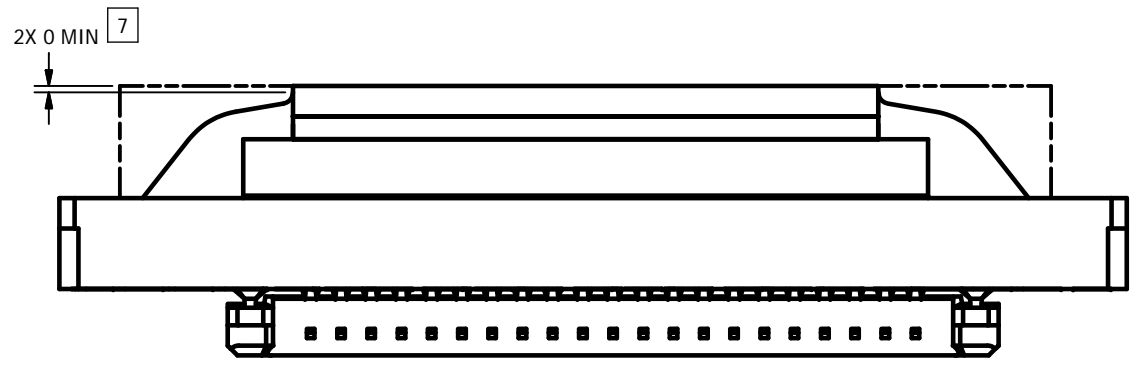

**VIEW D**  
 ENCAPSULANT MAXIMUM HEIGHT  
 SCALE 20 : 1

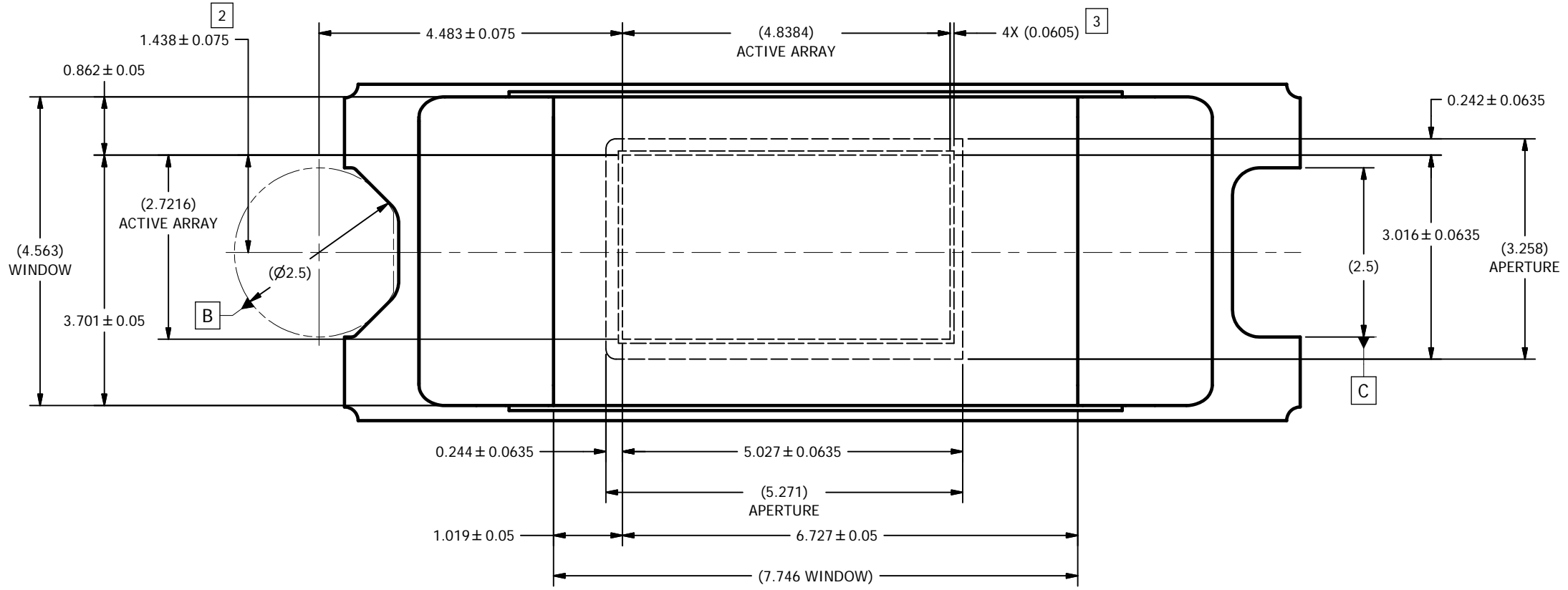

VIEW E  
WINDOW AND ACTIVE ARRAY  
(FROM SHEET 1)

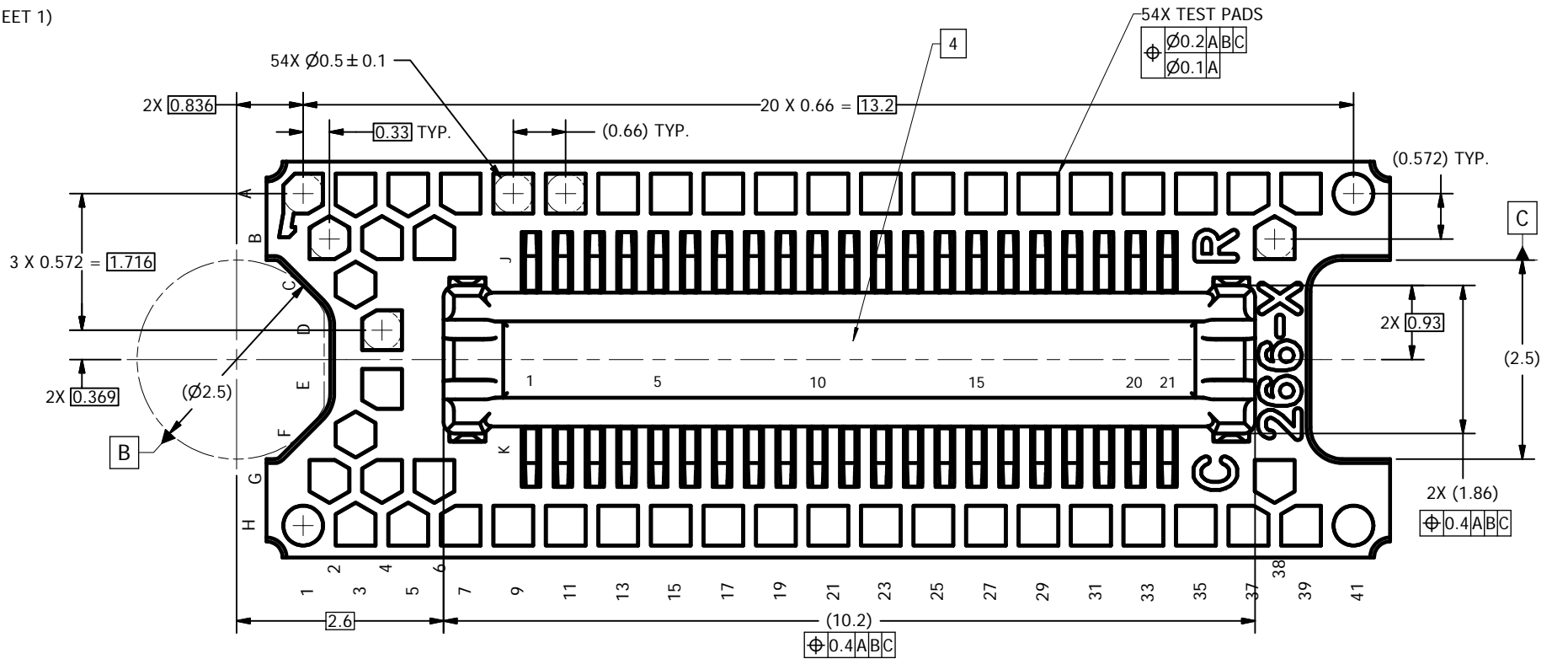

VIEW F-F  
TEST PADS AND CONNECTOR  
(FROM SHEET 1)

## IMPORTANT NOTICE AND DISCLAIMER

TI PROVIDES TECHNICAL AND RELIABILITY DATA (INCLUDING DATASHEETS), DESIGN RESOURCES (INCLUDING REFERENCE DESIGNS), APPLICATION OR OTHER DESIGN ADVICE, WEB TOOLS, SAFETY INFORMATION, AND OTHER RESOURCES "AS IS" AND WITH ALL FAULTS, AND DISCLAIMS ALL WARRANTIES, EXPRESS AND IMPLIED, INCLUDING WITHOUT LIMITATION ANY IMPLIED WARRANTIES OF MERCHANTABILITY, FITNESS FOR A PARTICULAR PURPOSE OR NON-INFRINGEMENT OF THIRD PARTY INTELLECTUAL PROPERTY RIGHTS.

These resources are intended for skilled developers designing with TI products. You are solely responsible for (1) selecting the appropriate TI products for your application, (2) designing, validating and testing your application, and (3) ensuring your application meets applicable standards, and any other safety, security, or other requirements. These resources are subject to change without notice. TI grants you permission to use these resources only for development of an application that uses the TI products described in the resource. Other reproduction and display of these resources is prohibited. No license is granted to any other TI intellectual property right or to any third party intellectual property right. TI disclaims responsibility for, and you will fully indemnify TI and its representatives against, any claims, damages, costs, losses, and liabilities arising out of your use of these resources.

TI's products are provided subject to TI's Terms of Sale ([www.ti.com/legal/termsofsale.html](http://www.ti.com/legal/termsofsale.html)) or other applicable terms available either on [ti.com](http://ti.com) or provided in conjunction with such TI products. TI's provision of these resources does not expand or otherwise alter TI's applicable warranties or warranty disclaimers for TI products.

Mailing Address: Texas Instruments, Post Office Box 655303, Dallas, Texas 75265  
Copyright © 2019, Texas Instruments Incorporated