

# 0.30MM CENTER FFC JUMPER CABLE CHART

"A" DIM.	2 ± .08 INCHES 51 ± 2 MM	4 ± .16 INCHES 102 ± 4 MM	6 ± .16 INCHES 152 ± 4 MM	8 ± .20 INCHES 203 ± 5 MM	10 ± .20 INCHES 254 ± 5 MM	12 ± .20 INCHES 305 ± 5 MM
CKTS: 7	150310207	150310407	150310607	150310807	150311007	150311207
CKTS: 9	150310209	150310409	150310609	150310809	150311009	150311209
CKTS: 11	150310211	150310411	150310611	150310811	150311011	150311211
CKTS: 15	150310215	150310415	150310615	150310815	150311015	150311215
CKTS: 21	150310221	150310421	150310621	150310821	150311021	150311221
CKTS: 25	150310225	150310425	150310625	150310825	150311025	150311225
CKTS: 31	150310231	150310431	150310631	150310831	150311031	150311231
CKTS: 33	150310233	150310433	150310633	150310833	150311033	150311233
CKTS: 35	150310235	150310435	150310635	150310835	150311035	150311235
CKTS: 37	150310237	150310437	150310637	150310837	150311037	150311237
CKTS: 39	150310239	150310439	150310639	150310839	150311039	150311239
CKTS: 41	150310241	150310441	150310641	150310841	150311041	150311241
CKTS: 51	150310251	150310451	150310651	150310851	150311051	150311251
CKTS: 61	150310261	150310461	150310661	150310861	150311061	150311261

- NOTES:**
- SUBSTRATE AND COVERLAY MATERIAL IS .001" [25μM] POLYIMIDE.
  - CONDUCTOR IS 1/2 OZ (.0007") [18μM] COPPER.
  - PLATING IS 2 MICRO INCHES MINIMUM OF HARD GOLD OVER 100 MICRO INCHES MINIMUM OF NICKEL.
  - TAIL ENDS ARE .008±.001 [0.20±0.03] THICK.
  - JUMPER CABLES ARE SUITABLE FOR USE WITH MOLEX 504754 SERIES CONNECTOR.

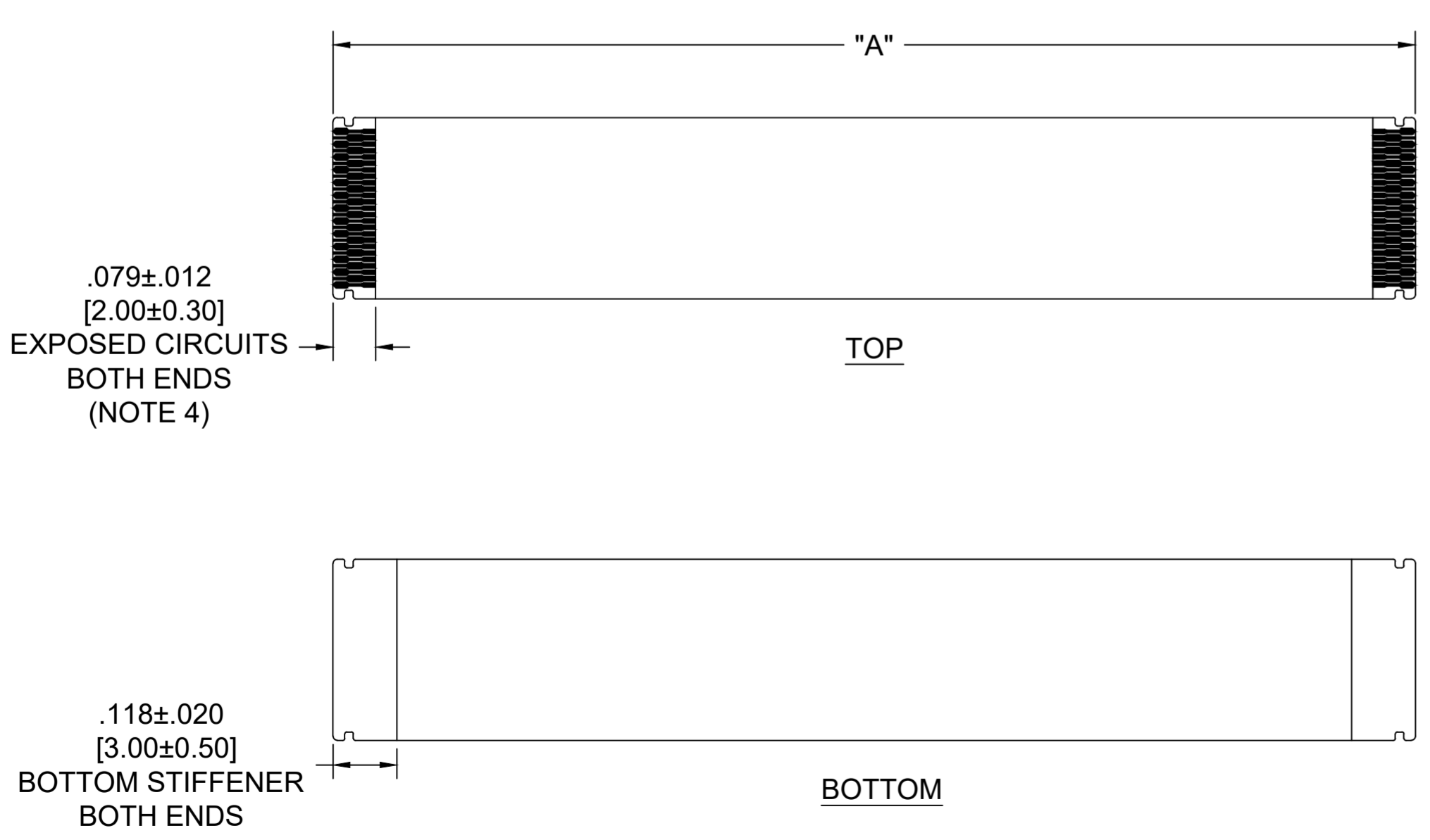
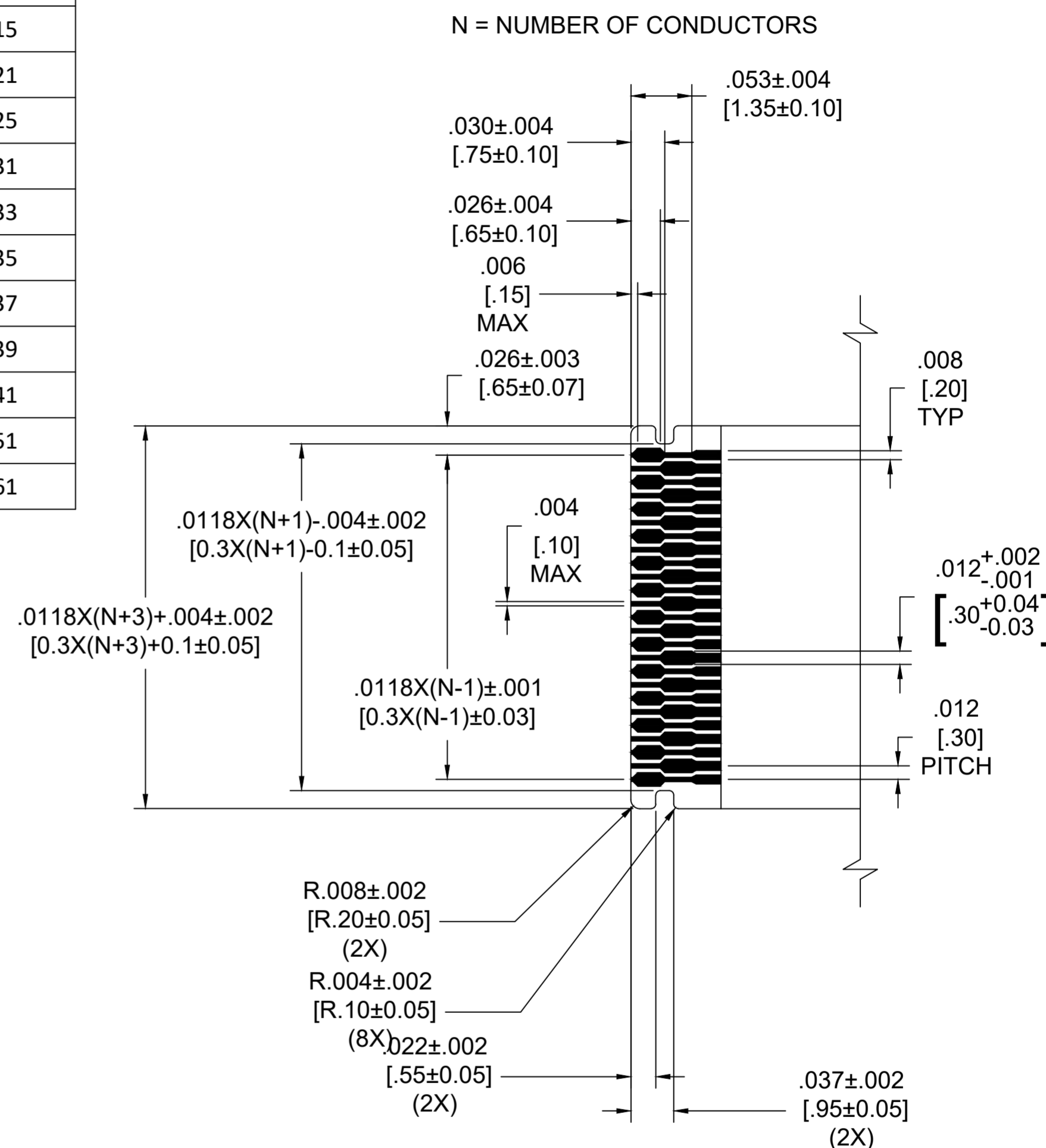

<b>FUNCTIONAL SYMBOLS</b> $\overline{FA}=0$ $\overline{EC}=0$ $\overline{EP}=0$ <b>DIVISIONAL SYMBOLS</b>	THIS DRAWING CONTAINS INFORMATION THAT IS PROPRIETARY TO MOLEX ELECTRONIC TECHNOLOGIES, LLC AND SHOULD NOT BE USED WITHOUT WRITTEN PERMISSION			CURRENT REV DESC: PRODUCTION RELEASE		
	DIMENSION UNITS: <b>MM/INCH</b>		SCALE: <b>4:1</b>	<b>molex</b> .3MM PITCH JUMPER CABLES		
	GENERAL TOLERANCES (UNLESS SPECIFIED)					
	4 PLACES	±----	±----			
3 PLACES	±----	±0.01	EC NO: 701160	DRWN: MIMIG	2022/03/28	
2 PLACES	±----	±0.03	CHK'D: JSMITH11	APPR: JSMITH11	2022/03/30	
1 PLACE	±----	±----	INITIAL REVISION:			
0 PLACES	±----	±----	DRWN: MIMIG	2022/03/28		
ANGULAR TOL ± 1.0 °			APPR: JSMITH11	2022/03/30		
DRAFT WHERE APPLICABLE MUST REMAIN WITHIN DIMENSIONS			THIRD ANGLE PROJECTION	DRAWING: C-SIZE	SERIES: 15031	
DOCUMENT STATUS: P1	RELEASE DATE: 2022/03/30	23:34:44	MATERIAL NUMBER: SEE CHART	CUSTOMER: GENERAL MARKET	SHEET NUMBER: 1 OF 1	