

DRAWING

General tolerance: ± 0,5 mm

R574 313635

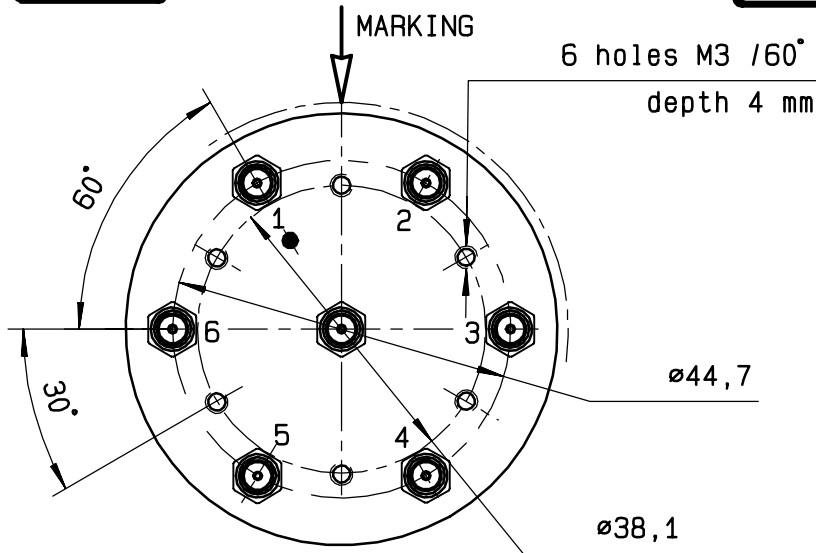

Voltage	RF continuity	Ind.
-C +1	IN ↔ 1	D.E
-C +2	IN ↔ 2	D.F
-C +3	IN ↔ 3	D.G
-C +4	IN ↔ 4	D.H
-C +5	IN ↔ 5	D.I
-C +6	IN ↔ 6	D.J

4-40 UNC 25 pins D-SUB male connector

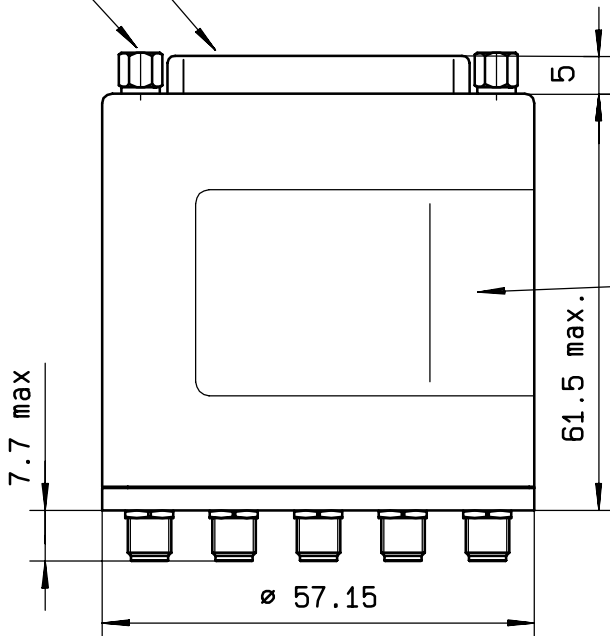

MARKING TOP VIEW (TERMINALS)

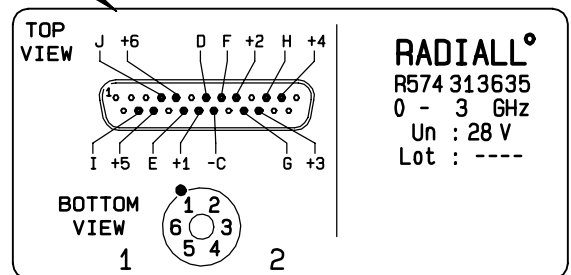

RADIALL
 R574 313635
 0 - 3 GHz
 Un : 28 V
 Lot : ----

SCHEMATIC DIAGRAM

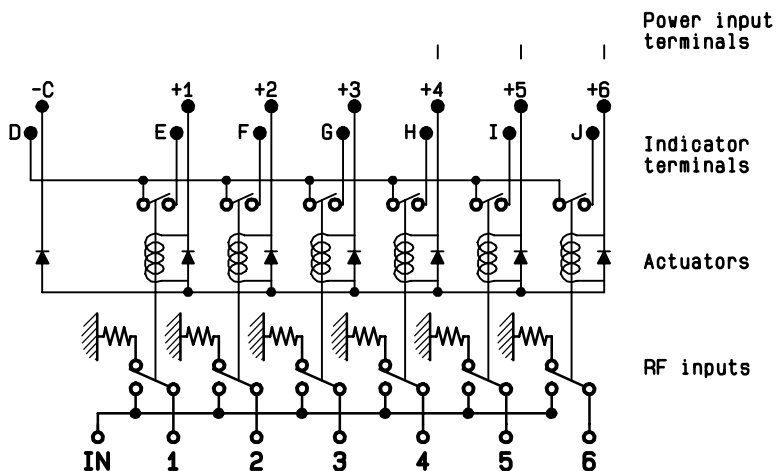

4113-9212 This information is given as an indication. In the continual goal to improve our products, we reserve the right to make any modifications judged necessary