

PRE - ASSEMBLY INSTRUCTIONS:

Caution: Check gasket on top of base unit for damage before assembly. If cut or torn, contact Hammond Manufacturing for immediate replacement.

Note: When assembling total modular system build from the floor up for assembly ease. Plinth > Base Unit > Desk Unit > Turret

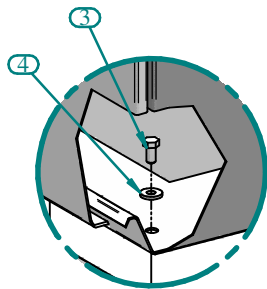
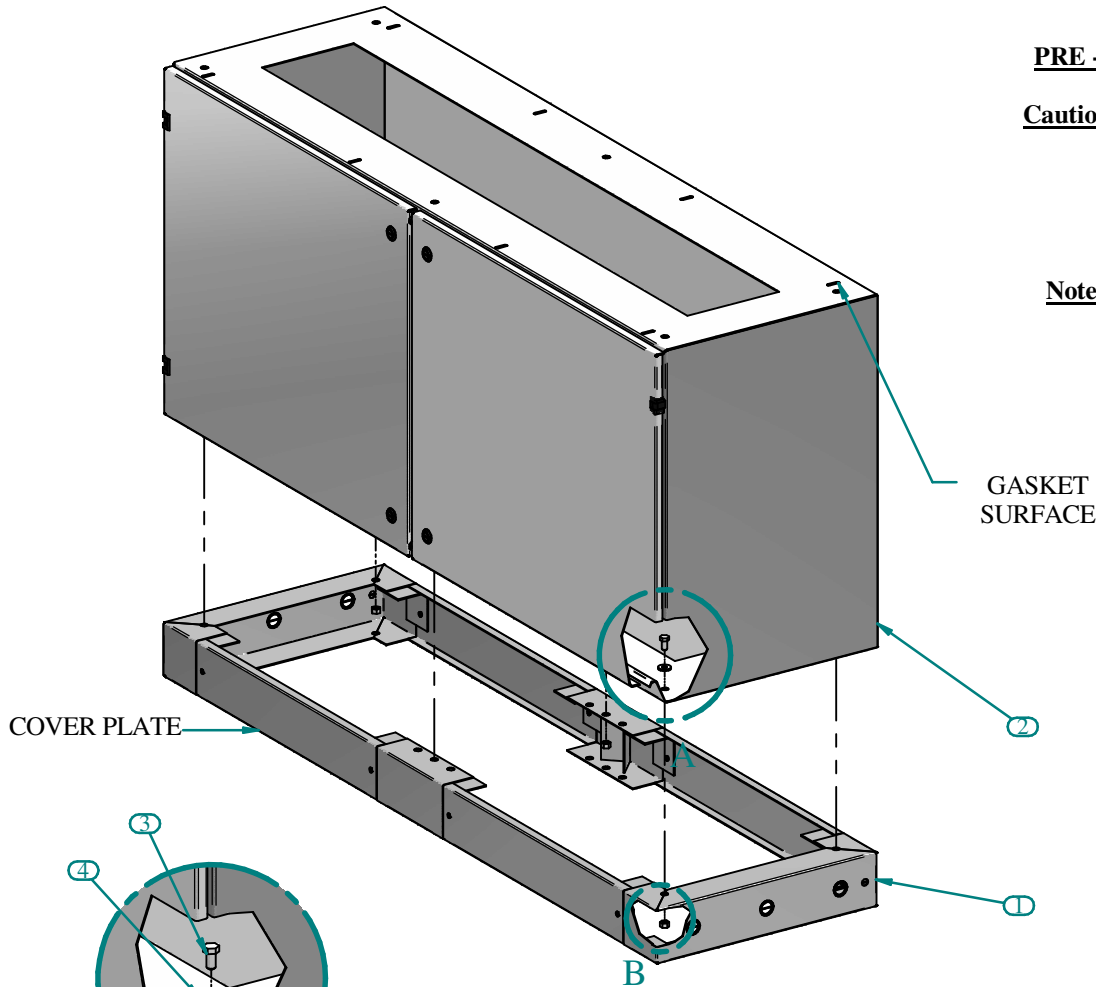

DETAIL A

SEE STEP G FOR INSTRUCTIONS

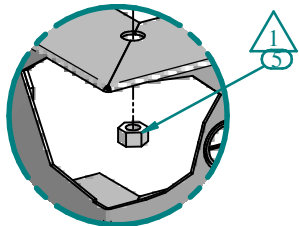

DETAIL B

ASSEMBLY INSTRUCTIONS:

- A) Layout plinth (item 1) on floor, square plinth and mark and drill 5/16"(8.0mm) dia. hole for 3/8 LAG bolts (4) - not supplied.
- B) LAG assembled plinth to floor. Assure that plinth is square and accurate.
- C) Open or remove doors on base unit (item 2) for ease of assembly. This will allow for visual alignment of mating parts. Remove .5 dia knockouts in bottom of base unit.
- D) Align base unit over top opening in plinth unit. Side edges of base unit and plinth are to be flush.
- E) Front and rear holes in the base unit bottom are to be aligned with mounting holes on plinth top.
- F) Once the base unit is seated properly on the plinth remove cover plates on plinth.
- G) Assemble using 3/8-16 x .75 hex head bolts and 3/8 nuts and sealing washers (items 3, 4 & 5). Torque bolts and nuts to 180 in/lbs.

PARTS LIST

ITEM No.	DESCRIPTION	QTY
1	PLINTH	1
2	BASE UNIT	1
3	3/8-16 X 3/4 HEX CAP SCREW	4 or 6
4	3/8 SEALING WASHER	4 or 6
5	3/8 HEX NUT	4 or 6

TOOL BOX

