

ALTERNATE TIP
GEOMETRY
SEE NOTE 7

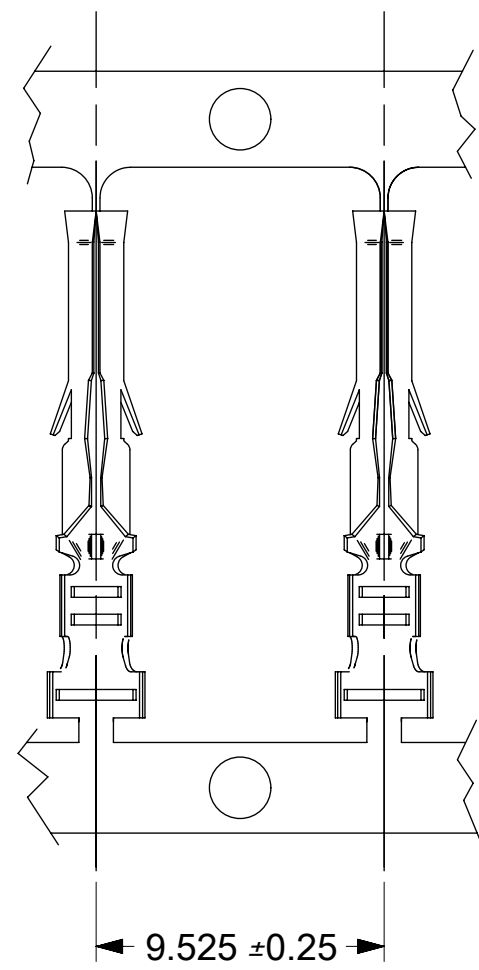

CHAIN FORM
SCALE: 4:1

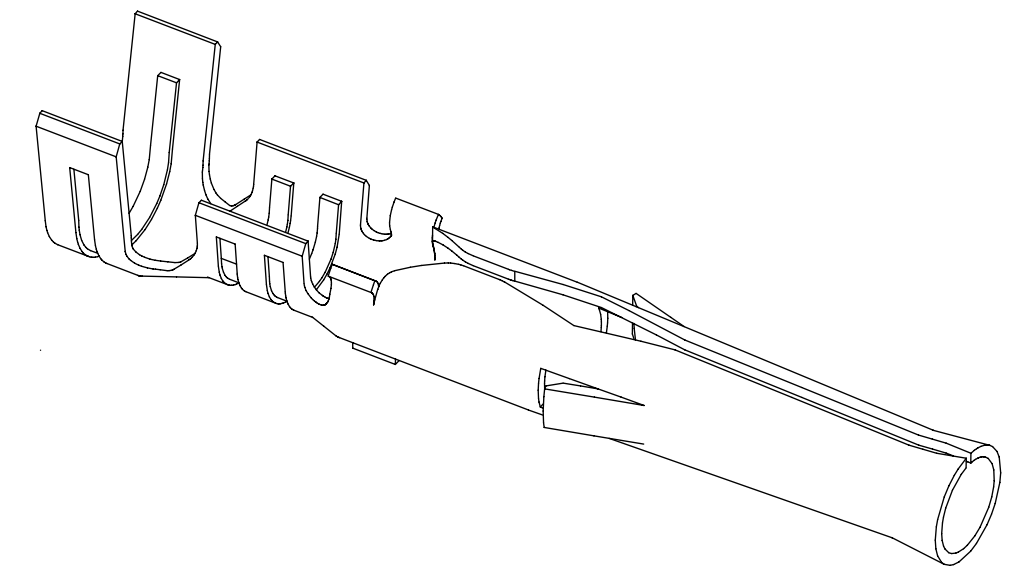
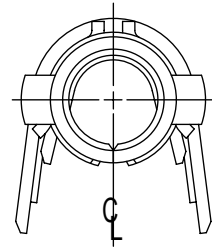
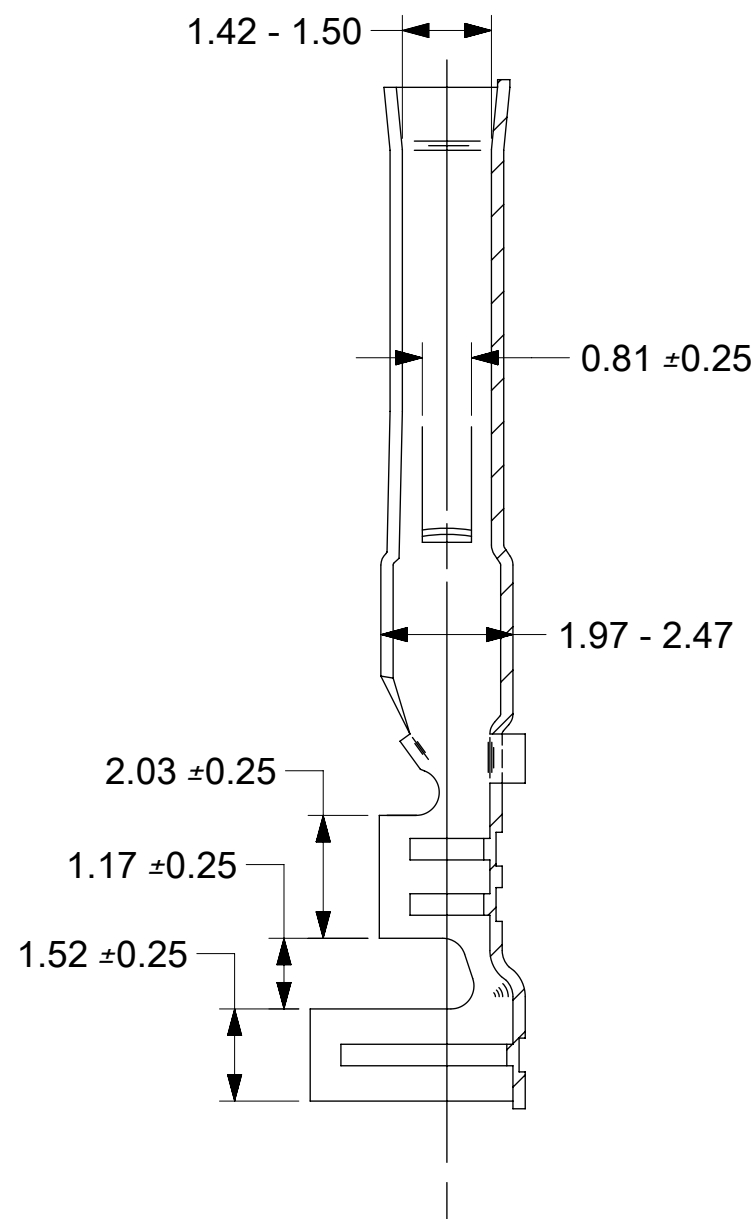
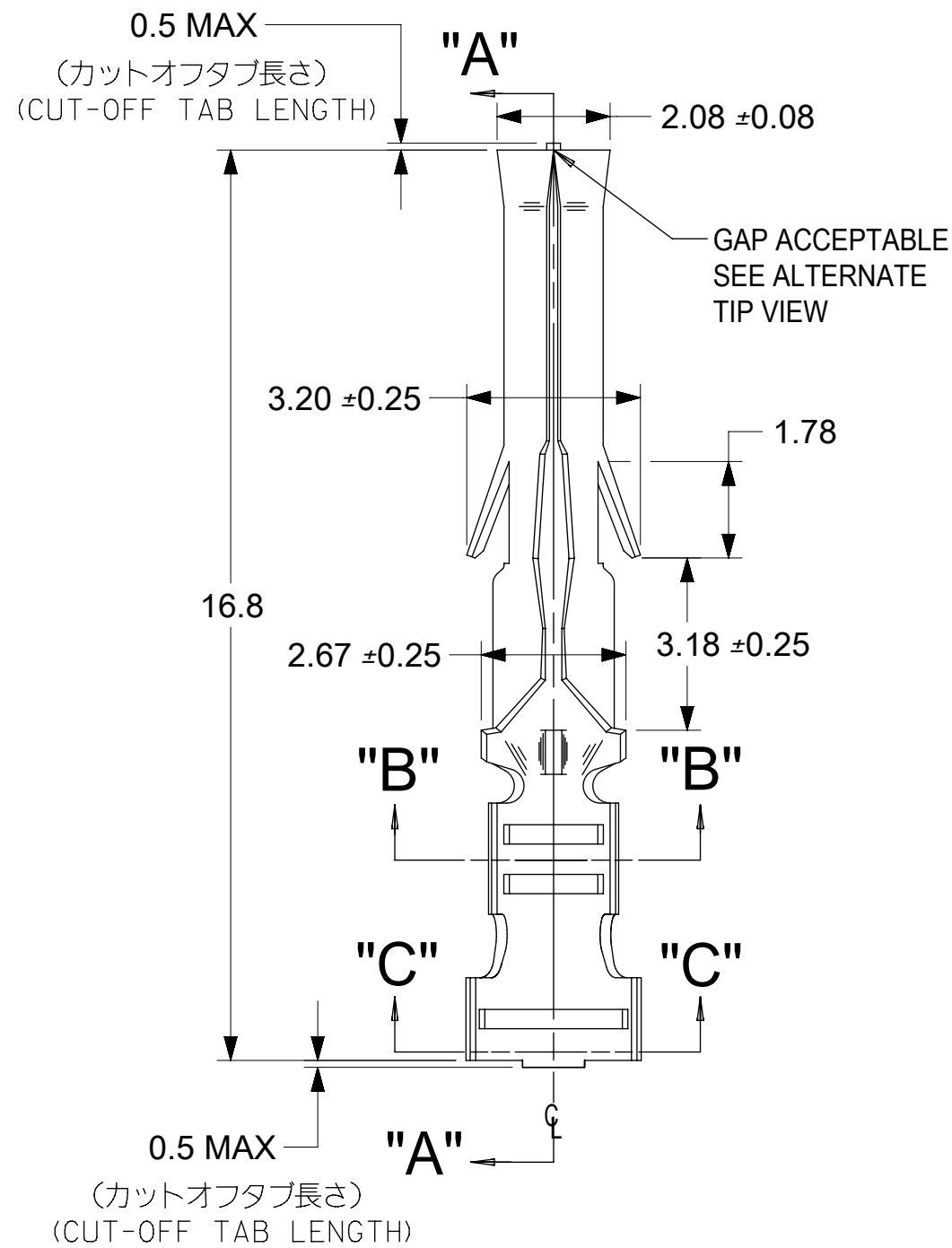

SECT. "A-A"

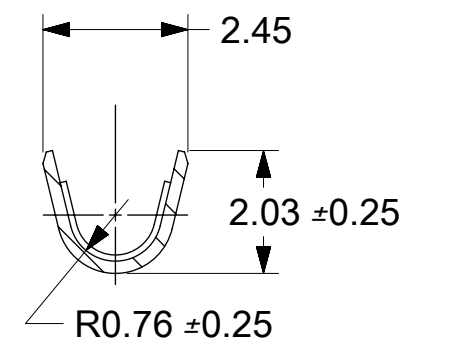

SECT. "B-B"

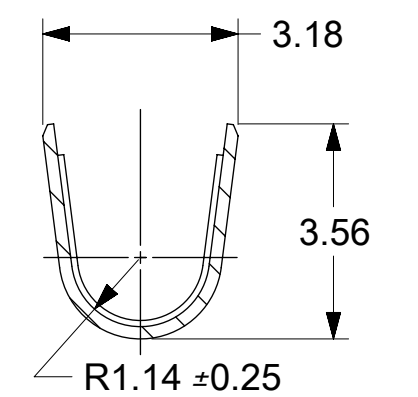

SECT. "C-C"

NOTES:

1. MATERIAL: BRASS
2. FINISH: SEE CHART
3. PRODUCT SPECIFICATION: PS-02-06
4. PACKAGING INFORMATION: 15610000-PK
5. TERMINAL FOR USE WITH (1.57)/.062 DIA. SERIES HOUSINGS AND WILL ACCEPT 18 THRU 24 AWG WIRE WITH 1.5/3.1 INSULATION DIA.
6. PARTS CONFORM TO CLASS B REQUIREMENTS OF COSMETIC SPECIFICATION PS-45499-002.
7. TIP GEOMETRY IS TOOL DEPENDENT. EITHER GEOMETRY IS ACCEPTABLE.

一般公差: ±0.4
GENERAL TOLERANCES: ±0.4

銅 (0.5 μm MIN.) 下地 錫 (0.9 μm MIN.) TIN (0.9 μm MIN.) OVER COPPER (0.5 μm MIN.)	39-00-0331	156 ITL	バラ端子 LOOSE
メッキ PLATING	EDP.NO.	ENG.NO.	連鎖端子 CHAIN 形状 FORM

SYMBOLS				THIS DRAWING CONTAINS INFORMATION THAT IS PROPRIETARY TO MOLEX ELECTRONIC TECHNOLOGIES, LLC AND SHOULD NOT BE USED WITHOUT WRITTEN PERMISSION			
DIMENSION UNITS		SCALE		CURRENT REV DESC: UPDATE GRAPHICS, REMOVE 1561G AND GL			
mm		8:1		EC NO: 632666			
GENERAL TOLERANCES (UNLESS SPECIFIED)				DRWN: MKIPPER 2019/03/06			
ANGULAR TOL ± °				CHK'D: DSTEIER 2020/02/26			
4 PLACES ±				APPR: FSMITH 2020/06/05			
3 PLACES ±				INITIAL REVISION:			
2 PLACES ±				DRWN: YAOYAGI 2009/02/16			
1 PLACE ±				APPR: NUKITA 2009/02/17			
0 PLACES ±				DRAFT WHERE APPLICABLE MUST REMAIN WITHIN DIMENSIONS			
THIRD ANGLE PROJECTION		DRAWING		SERIES		MATERIAL NUMBER	
C-SIZE		1561		SEE CHART		CUSTOMER	
DOCUMENT NUMBER		DOC TYPE		DOC PART		REVISION	
SD-1561-001		PSD		001		M	
SHEET NUMBER		GENERAL MARKET		1 OF 1			

材料 MATERIAL	黄銅 BRASS 0.2 t
仕上げ FINISH	
適用電線範囲 WIRE RANGE	AWG# 18-#24
被覆外径 INS. RANGE	∅ 1.5~3.1

molex

.062 DIA CRIMP FEMALE
TERMINAL

PRODUCT CUSTOMER DRAWING

DOCUMENT NUMBER DOC TYPE DOC PART REVISION

SD-1561-001 PSD 001 M

MATERIAL NUMBER CUSTOMER SHEET NUMBER

SEE CHART GENERAL MARKET 1 OF 1