

NOTES.

1. MATERIAL : SEE TABLE

| N | PRODUCT | | MATERIAL | |
|---|------------|-------------|----------|-------------------|
| | PART NO | MATERIAL NO | COLOR | DESCRIPTION |
| 0 | | | | |
| 1 | 35151-0210 | 351510210 | NATURAL | PBT UL94V-0 |
| 2 | 35151-0211 | 351510211 | BLACK | |
| 3 | 35151-0212 | 351510212 | RED | |
| 4 | 35151-0214 | 351510214 | BLUE | PC/PET UL94V-0 |
| 5 | 35151-0219 | 351510219 | NATURAL | |
| 6 | 35151-2219 | 351512219 | RED | |
| 7 | 35151-3219 | 351513219 | YELLOW | |
| 8 | 35151-4219 | 351514219 | BLUE | |

- 2. MATED HOUSING : 35150-020*, 35150-021*
- 3. APPLICABLE TERMINAL : 35746-0*10
- 4. APPLICABLE T.P.A : 35150-0290
- 5. PRODUCT SPECIFICATION : PS-35150-001

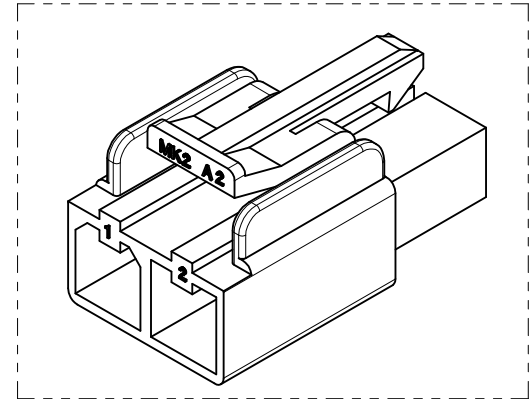

| | | | | | | |
|--|-----------------|---|---------------------|---|--------------------|------------------------|
| REVISED EC NO: KOR2010-0179 DRWN: JHPARK01 2010/05/25 CHKD: KSKIM APPR: YSKIM02 2012/02/20 | QUALITY SYMBOLS | GENERAL TOLERANCES (UNLESS SPECIFIED) | DIMENSION STYLE | SCALE | DESIGN UNITS | THIRD ANGLE PROJECTION |
| | ▽=0 ▽=0 | mm INCH 4 PLACES ± --- ± --- 3 PLACES ± --- ± --- 2 PLACES ± --- ± --- 1 PLACE ± 0.30 ± --- ANGULAR ± 1° | MM ONLY | 3:1 | METRIC | |
| | DESCRIPTION | DRAFT WHERE APPLICABLE MUST REMAIN WITHIN DIMENSIONS | DRAWN BY DATE | TITLE | MOLEX INCORPORATED | |
| | REV | | JS. KANG 1992/11/17 | 6.2 PITCH W/W CONN FEMALE HSG-2P | DOCUMENT NO. | SHEET NO. |
| | | CW. LEE 1992/11/17 | SEE TABLE | SD-35151-021* | 1 OF 01 | |
| | | | SIZE A3 | THIS DRAWING CONTAINS INFORMATION THAT IS PROPRIETARY TO MOLEX INCORPORATED AND SHOULD NOT BE USED WITHOUT WRITTEN PERMISSION | | |