

Product Document



austriamicrosystems AG

is now

ams AG

The technical content of this austriamicrosystems document is still valid.

Contact information:

Headquarters:

ams AG
Tobelbaderstrasse 30
8141 Unterpremstaetten, Austria
Tel: +43 (0) 3136 500 0
e-Mail: ams_sales@ams.com

Please visit our website at www.ams.com

AS5245

Programmable Magnetic Rotary Encoder

AS5245-AB-v1.0 Adapterboard

OPERATION MANUAL

1 General Description

The AS5245 is a contactless magnetic angle encoder for accurate measurement up to 360° and includes two AS5145 devices in a punched stacked leadframe. It is a system-on-chip, combining integrated Hall elements, analog front end and digital signal processing in a single device. To measure the angle, only a simple two-pole magnet, rotating over the center of the chip is required. The magnet may be placed above or below the IC. The absolute angle measurement provides instant indication of the magnet's angular position with a resolution of $0.0879^\circ = 4096$ positions per revolution. This digital data is available as a serial bit stream and as a

PWM signal. An internal voltage regulator allows operation of the AS5245 from 3.3V or 5.0V supplies.

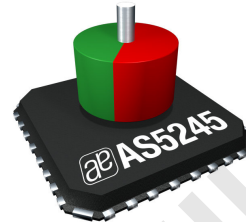

2 The AS5245 Adapter board

2.1 Board description

The AS5245 adapter board is a simple circuit allowing test and evaluation without building a test fixture or PCB. The PCB can be used as standalone unit or attached to a microcontroller. The standalone operation requires a 5V or 3.3V power supply only; the magnet's angle can be read on the PWM or analog output.

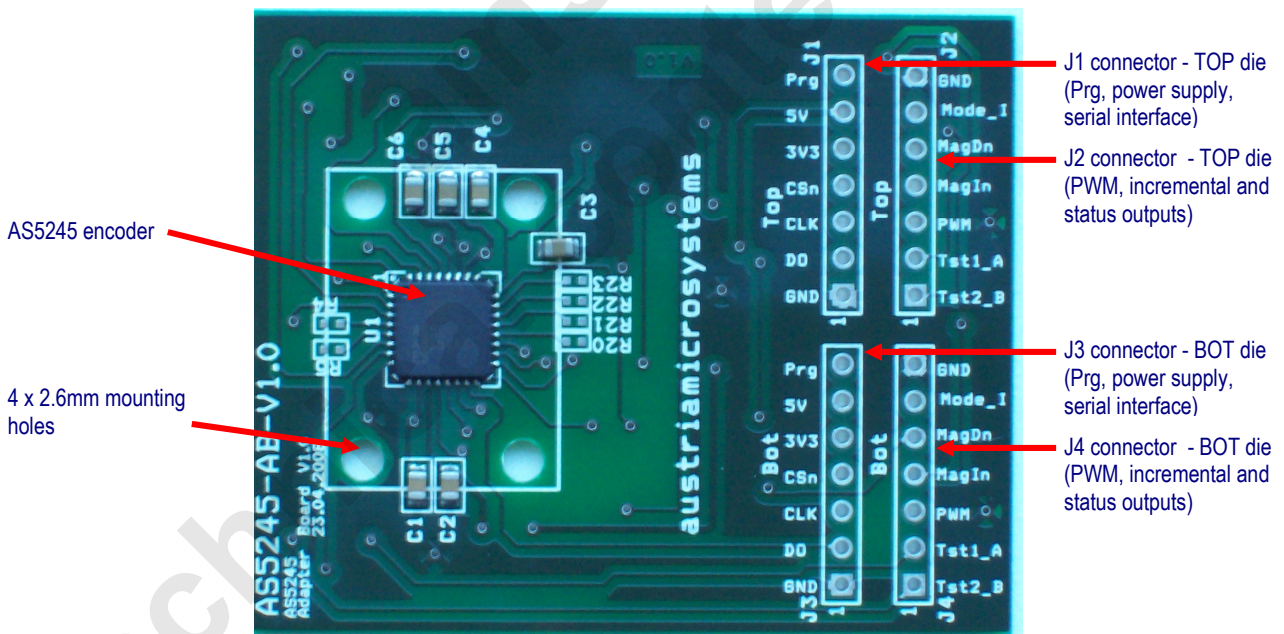

Figure 1: AS5245 Adapterboard

2.2 Mounting the AS5245 adapter board

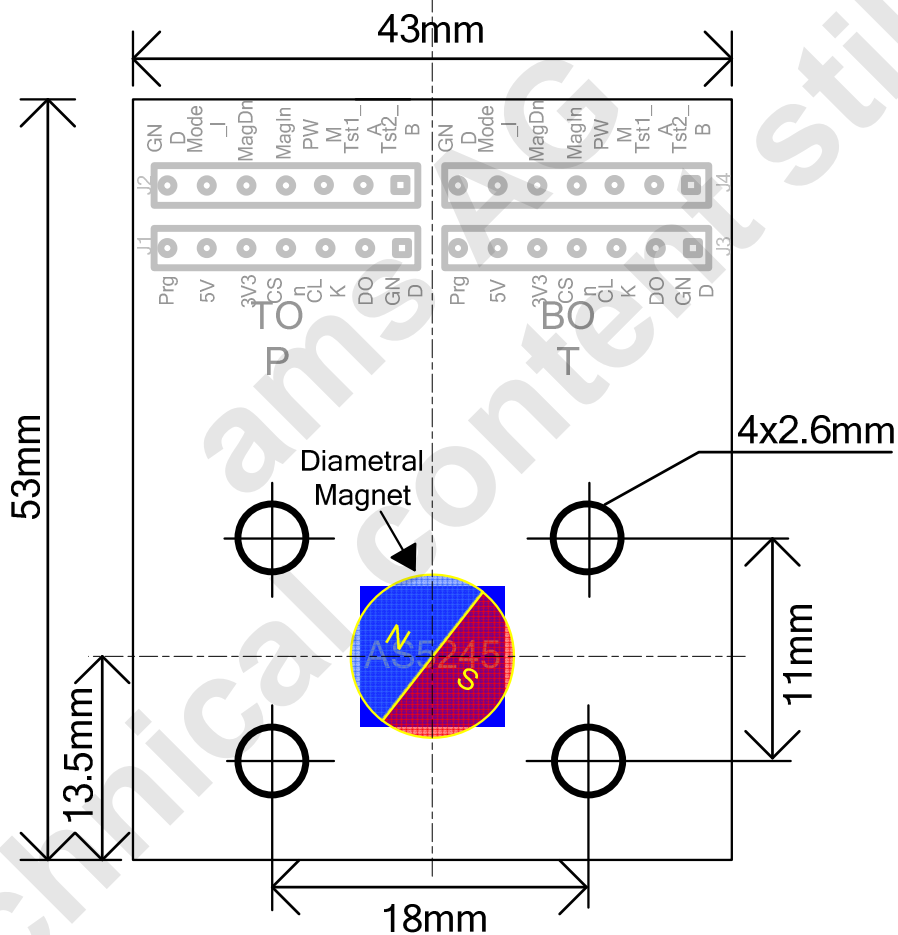
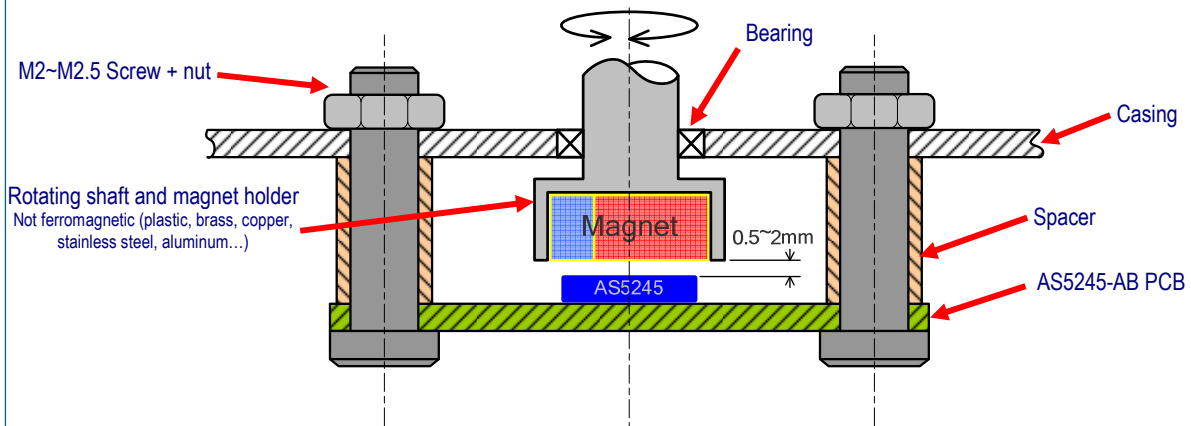

Figure 2: AS5245 adapter board mounting and dimension

A diametral magnet must be placed over on under the AS5245 encoder, and should be centered on the middle of the package with a tolerance of 0.5mm.

The airgap between the magnet and the encoder casing should be maintained in the range 0.5mm~2mm.

The magnet holder must not be ferromagnetic. Materials as brass, copper, aluminum, stainless steel are the best choices to make this part.

3 AS5245 and adapter board pinout

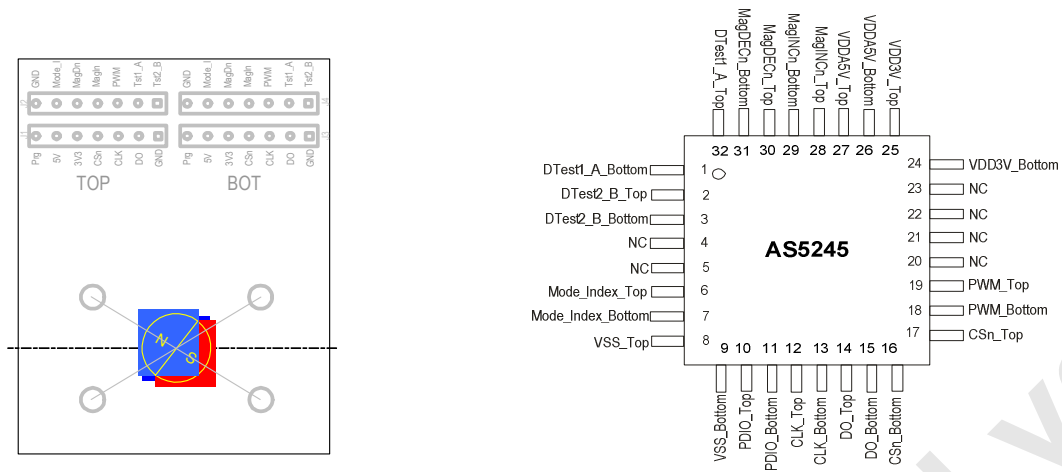

Figure 3: AS5245 adapter board connectors and encoder pinout

Pin# Board	Pin# AS5245	Symbol Board	Type	Description
JP1/3 - 1	8, 9	GND	S	Supply ground
JP1/3 - 2	14, 15	DO	DO_T	Data Output of Synchronous Serial Interface
JP1/3 - 3	12, 13	CLK	DI_ST	Clock Input of Synchronous Serial Interface; Schmitt-Trigger input
JP1/3 - 4	16, 17	CSn	DI_PU_ST	Chip Select, active low; Schmitt-Trigger input, internal pull-up resistor (~50kΩ) connect to VSS in incremental mode
JP1/3 - 5	24, 25	3V3	S	3V-Regulator Output
JP1/3 - 6	26, 27	5V	S	5V Supply
JP1/3 - 7	10, 11	Prg	DI_PD	OTP Programming Input and Data Input for Daisy Chain mode. Internal pull-down resistor (~74kΩ). May be connected to VSS if programming is not used
JP2/4 - 1	2, 3	Tst2_B	DO	Test output in default mode
JP2/4 - 2	1, 32	Tst1_A	DO	Test output in default mode
JP2/4 - 3	18, 19	PWM	DO	Pulse Width Modulation of approx. 244Hz; 1μs/step (opt. 122Hz; 2μs/step)
JP2/4 - 4	28, 29	MagIn	DO_OD	Magnet Field Magnitude INCREASE ; active low, indicates a distance reduction between the magnet and the device surface.
JP2/4 - 5	30, 31	MagDn	DO_OD	Magnet Field Magnitude DECREASE ; active low, indicates a distance increase between the device and the magnet.
JP2/4 - 6	6, 7	Mode_I	DIO_PD	Select between slow (open, low: VSS) and fast (high) mode. Internal pull-down resistor.
JP2/4 - 7	8, 9	GND	S	Supply ground

Table 1: Pin description

Pin types:	DO_OD	digital output open drain	S	supply pin
	DI_PD	digital input pull-down	DO_T	digital output /tri-state
	DI_PU	digital input pull-up	ST	schmitt-trigger input
	DI	digital input		

4 Operation use cases

4.1 Standalone SSI output mode

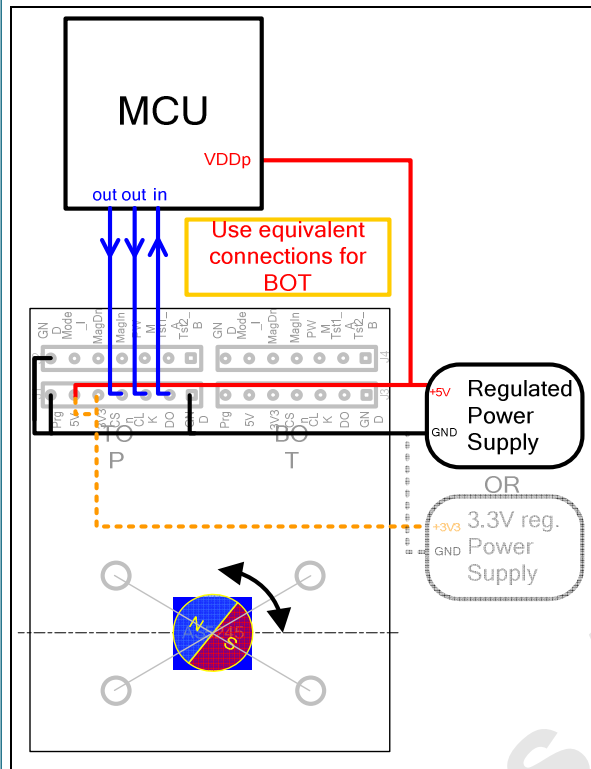

Figure 4: Using the SSI output with the adapter board

The most complete and accurate solution for a MCU to read the angle of a magnet is the serial interface. The serial word contains 18 bits and consists of 12 bit angle value and some other indicator bits like MagINC, MagDEC, which can be read at the same time.

4.2 Standalone PWM output mode

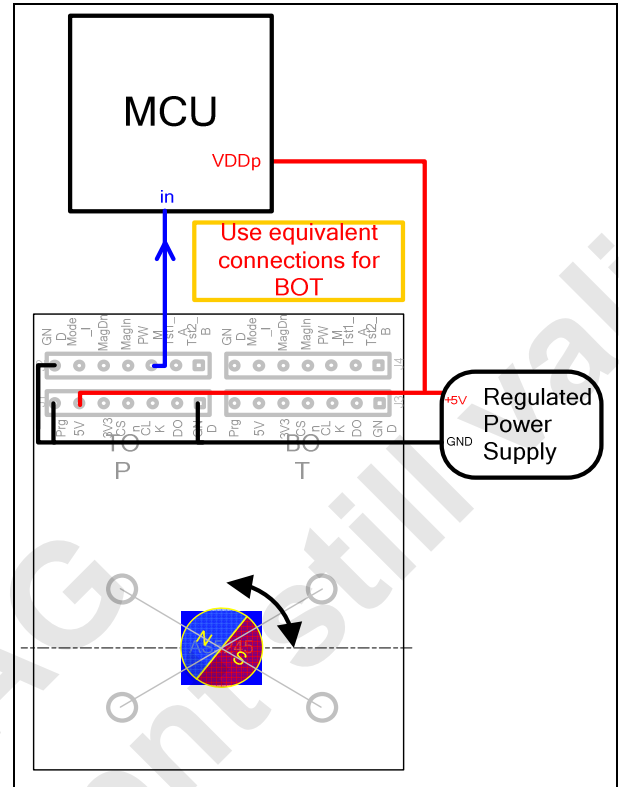

Figure 5: Using the PWM output with the adapter board

The AS5245 provides a pulse width modulated output (PWM), whose duty cycle is proportional to the measured angle. The PWM signal (J2/4 pin #3) with a period of 1025 μ s (1 μ s step) and 5V pulse voltage (in case of 5V power supply) can be connected to the capture/timer input of a microcontroller in order to decode the angle value.

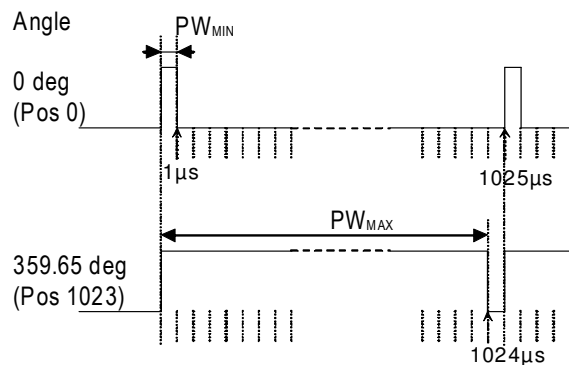

Figure 6: PWM duty cycle depending on magnet position

4.3 Standalone incremental output

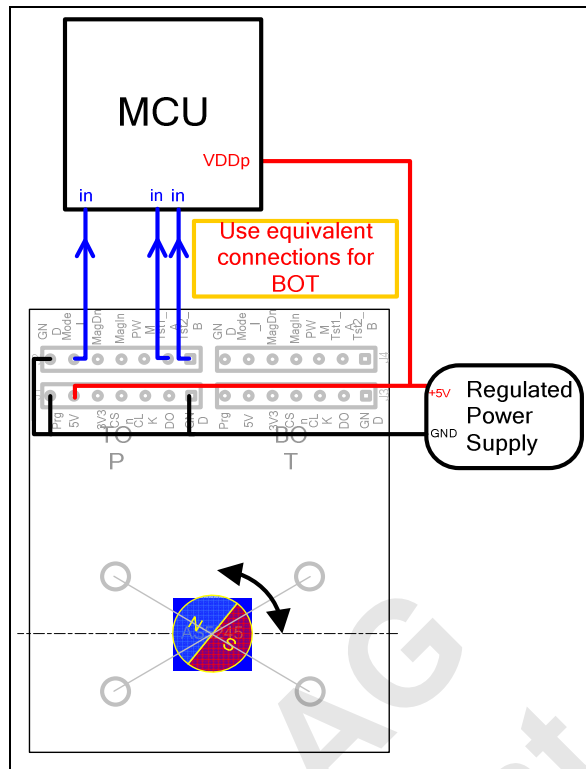

Figure 7: Using the Incremental output with the adapter board

The quadrature mode is enabled by programming the related OTP bits (Md0, Md1).

For further information, please refer to datasheet.

4.4 Daisy chain mode

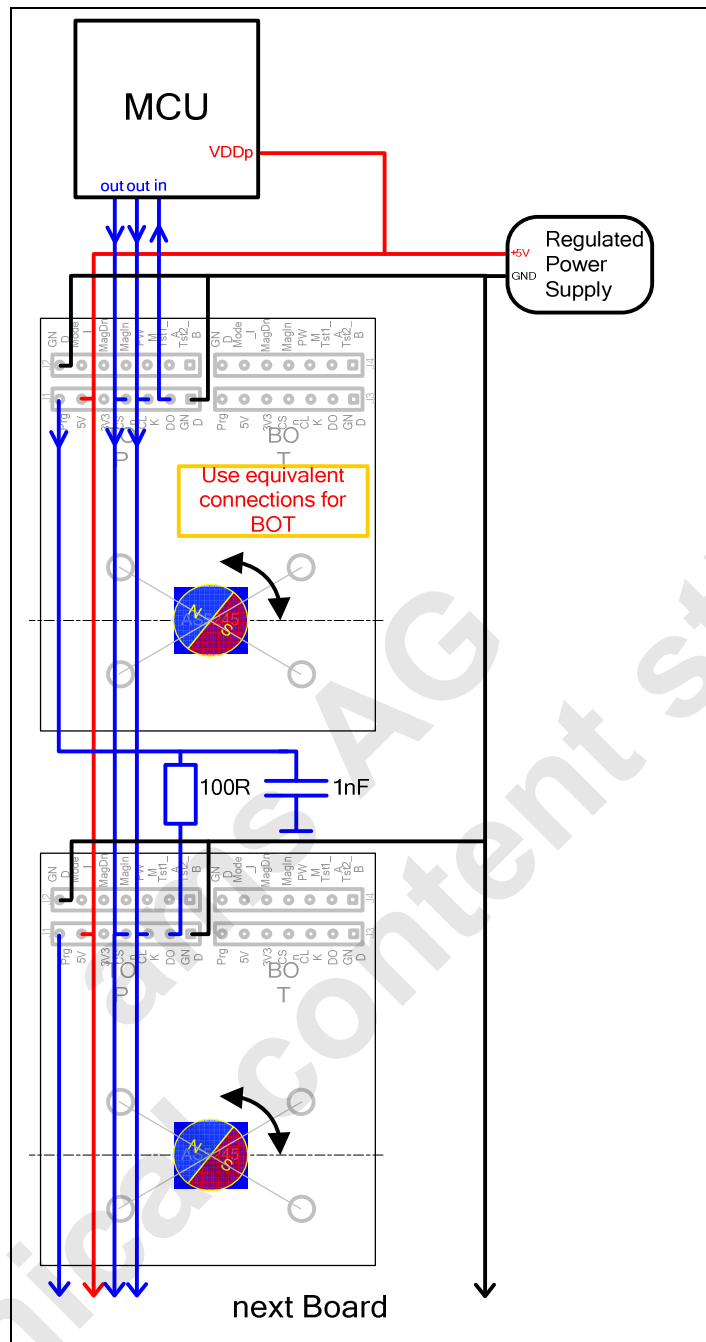

Figure 8: Using Daisy-Chain mode with the adapter board

By using more than one adapter board, a setup in daisy chain mode is possible.

In this mode capacitor C2 (refer to Fig.10) must be disconnected when using the 1nF capacitor shown in Fig.8. or directly replaced by this capacitor.

The serial data of all connected devices is read from the DO pin of the first device in the chain. The Prog pin of the last device in the chain should be connected to VSS. The length of the serial bit stream increases with every connected device (board) by $n * (18+1)$ bits.

Due to $R = 100\Omega$ and $C = 1\text{nF}$, the CLK is limited the maximum 1MHz.

5 Programming the AS5245

ams AG
Technical content still valid

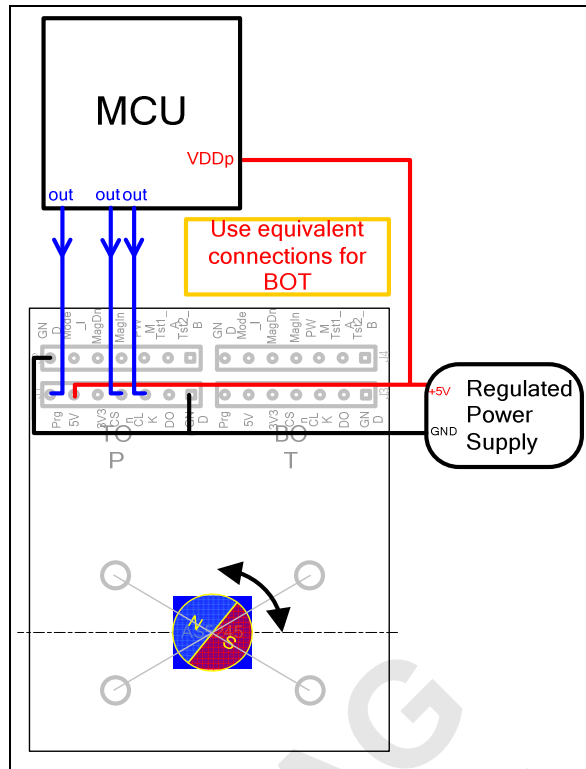

Figure 9: Programming the AS5245

After power-on, programming of the AS5245 is enabled with the rising edge of CSn with Prog = high and CLK = low. The OTP consists of 54 bits, of which 21 bits are available for user programming. The remaining 31 bits contain factory settings and a unique chip identifier (Chip-ID). 54 bit must be serially shifted into the OTP register via the Prog-pin, where “mbit1” is the first bit to be entered (please refer to datasheet). Data must be valid at the rising edge of CLK.

After writing data into the OTP register, it can be permanently programmed by rising the Prog pin to the programming voltage V_{PROG} of 3.3V-3.6V. 54 CLK pulses must be applied to program the fuses. For exiting the programming mode, the chip must be reset by a power-on-reset. The programmed data is available after the next power-up.

6 AS5245 adapter board hardware

6.1 AS5245-AB-1.0 schematics

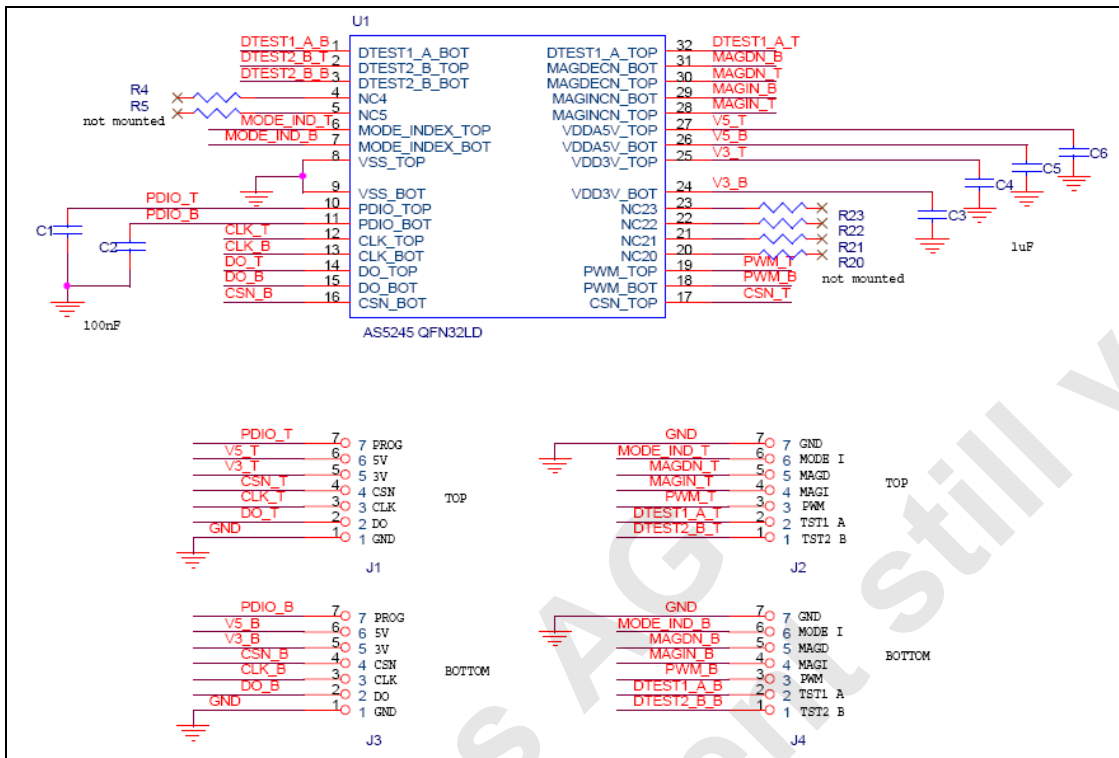

Figure 10: AS5245-AB-1.0 adapterboard schematics

6.2 AS5245-AB-1.0 PCB layout

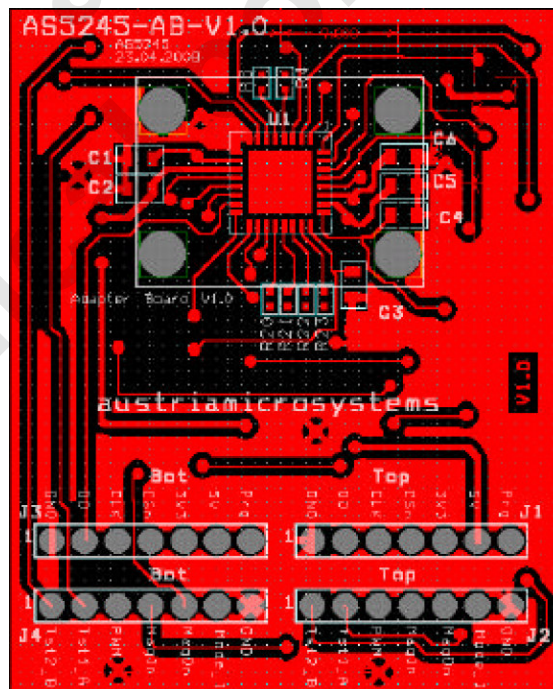

Figure 11: AS5245-AB-1.0 adapter board layout

Revision History

Revision	Date	Description
1.0	October , 2009	initial revision

Copyrights

Copyright © 1997-2009, austriamicrosystems AG, Schloss Premstaetten, 8141 Unterpremstaetten, Austria-Europe. Trademarks Registered ®. All rights reserved. The material herein may not be reproduced, adapted, merged, translated, stored, or used without the prior written consent of the copyright owner. All products and companies mentioned are trademarks or registered trademarks of their respective companies.

Disclaimer

Devices sold by austriamicrosystems AG are covered by the warranty and patent indemnification provisions appearing in its Term of Sale. austriamicrosystems AG makes no warranty, express, statutory, implied, or by description regarding the information set forth herein or regarding the freedom of the described devices from patent infringement. austriamicrosystems AG reserves the right to change specifications and prices at any time and without notice. Therefore, prior to designing this product into a system, it is necessary to check with austriamicrosystems AG for current information. This product is intended for use in normal commercial applications. Applications requiring extended temperature range, unusual environmental requirements, or high reliability applications, such as military, medical life-support or lifesustaining equipment are specifically not recommended without additional processing by austriamicrosystems AG for each application. The information furnished here by austriamicrosystems AG is believed to be correct and accurate. However, austriamicrosystems AG shall not be liable to recipient or any third party for any damages, including but not limited to personal injury, property damage, loss of profits, loss of use, interruption of business or indirect, special, incidental or consequential damages, of any kind, in connection with or arising out of the furnishing, performance or use of the technical data herein. No obligation or liability to recipient or any third party shall arise or flow out of austriamicrosystems AG rendering of technical or other services.

Contact Information

Headquarters

austriamicrosystems AG
A-8141 Schloss Premstaetten, Austria
Tel: +43 (0) 3136 500 0
Fax: +43 (0) 3136 525 01

For Sales Offices, Distributors and Representatives, please visit:
<http://www.austriamicrosystems.com>