

THIS DOCUMENT IS THE PROPERTY OF KEYSTONE ELECTRONICS CORP. AND SHALL NOT BE REPRODUCED, DISTRIBUTED OR USED AS A BASIS FOR MANUFACTURE WITHOUT PRIOR WRITTEN PERMISSION FROM KEYSTONE ELECTRONICS CORP.

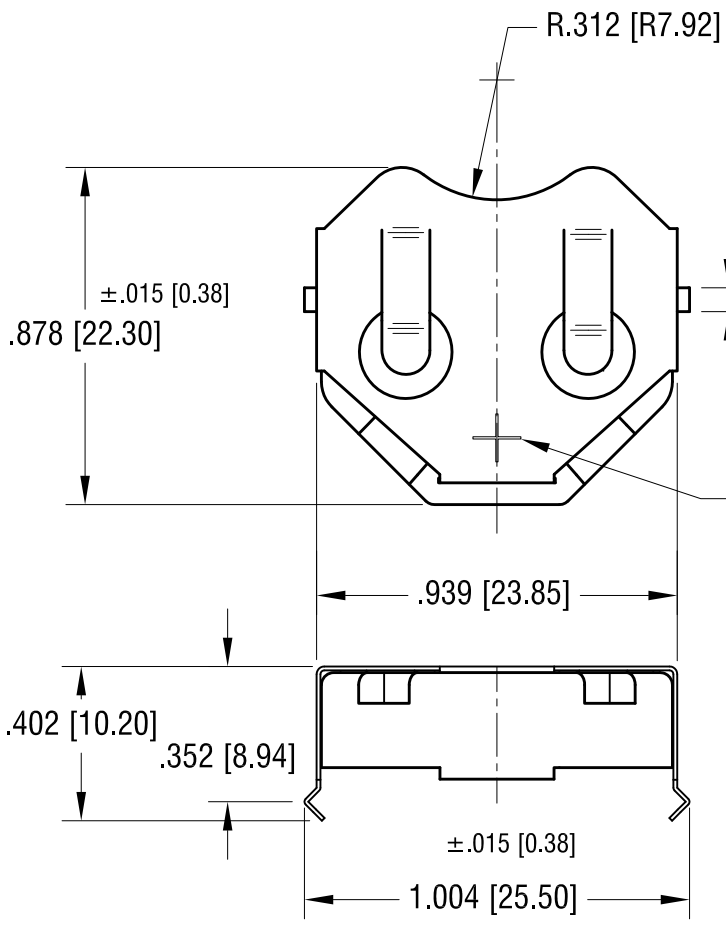

±.005 [0.15]
 .062 [1.57]
 (2) PLS

STAMP POLARITY (+)
 AS SHOWN

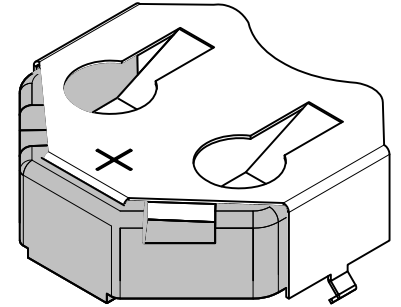
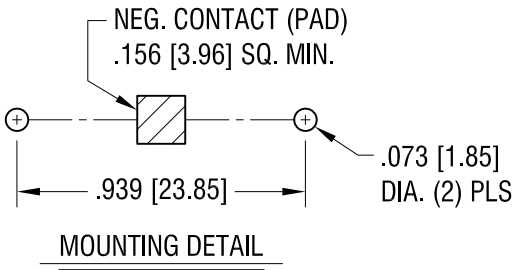
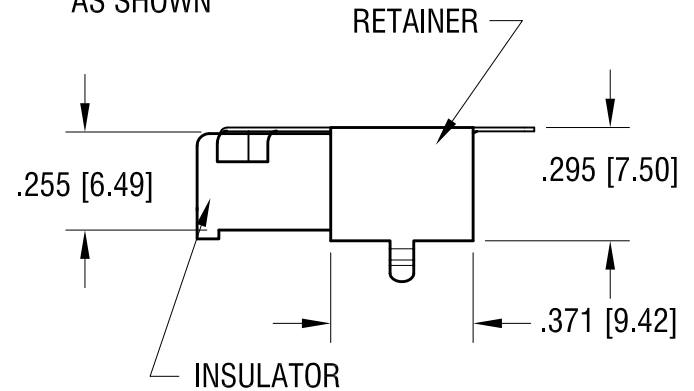

NOTE:

1. CLIP MAT'L: .010 TH'K FULL HARD PHOSPHOR BRONZE
 INSULATOR MAT'L: HIGH TEMPERATURE NYLON, UL 94V-0
2. CLIP FINISH: TIN NICKEL PLATE

KEYSTONE ELECTRONICS CORP.			
www.keyelco.com • ASTORIA, N.Y. 11105-2017 • Tel (718) 956-8900			
PART NAME THM COIN CELL CLIP FOR TWO 2032			
MATERIAL AS NOTED			
FINISH AS NOTED		DRN BY NT	DATE 6.01.10
		APP'D LN	SCALE 2X
TOLERANCES	INCH [MM]	CODE	DWG NO.
DECIMAL	± .010 [± 0.25]	C	3025
ANGULAR	± 1°		
UNLESS OTHERWISE SPECIFIED			

DATE	DESCRIPTION	REV.
------	-------------	------