



## Product summary

# C93-M8E application board

## u-blox M8 UDR application example

### Highlights

- Based on u-blox EVA-M8E module
- Complete small form factor UDR receiver
- Integrated sensor, flash, antenna and RTC
- USB and UART interfaces

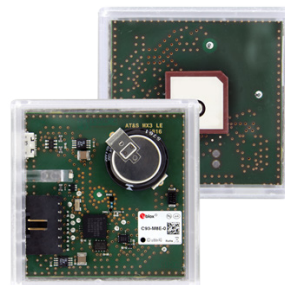

### Product description

Based on the EVA-M8E module, the C93-M8E enables immediate evaluation of u-blox's Untethered Dead Reckoning technology in most vehicle applications. The C93-M8E includes antenna, RTC and peripheral components required to complete an end-product design in a small case, ready for mounting in a vehicle application.

The C93 offers UART and USB interfaces and may be powered via USB or directly via pin header. The C93 may be installed in any stable position within the vehicle with adequate GNSS signal levels and needs no configuration.

u-blox UDR technology provides the benefits of Dead Reckoning (DR) without requiring speed information from the vehicle. The strength of UDR compared with GNSS alone is particularly apparent under poor signal conditions in urban environments, where it brings continuous positioning even to devices installed within the vehicle.

UDR positioning starts as soon as power is applied to the module, even before the first GNSS fix is available. For further details please see u-blox EVA-M8E and NEO-M8U product documentation.

### Features

Receiver type	72-channel u-blox M8 engine with inertial sensing GPS/QZSS L1 C/A, GLONASS L10F, BeiDou B1I, Galileo E1B/C SBAS L1 C/A: WAAS, EGNOS, MSAS, GAGAN
Nav. update rate	Up to 20 Hz
RTC crystal	On board, with internal battery
Flash	On board
Antenna	Internal

### Deliverable

PCB Schematic, layout and BOM available

### Block diagram

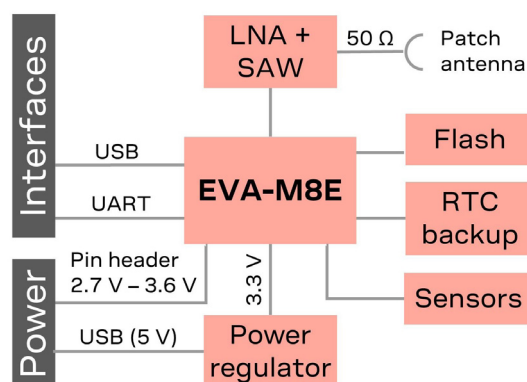

### Interfaces

UART	Pins for UART communication, 3.3 V
USB	Micro-USB for GNSS data and power supply
Power supply	USB, 5 V Pin header, 2.7 V - 3.6 V
LED	Timepulse
Protocols	NMEA, UBX binary, RTCM

### Support product

EVK-M8U	u-blox M8 Untethered Dead Reckoning GNSS Evaluation Kit, supports NEO-M8U and EVA-M8E
---------	---

### Product variants

C93-M8E-0	EVA-M8E application board, Untethered Dead Reckoning
-----------	--

### Legal Notice:

u-blox reserves all rights to this document and the information contained herein. Products, names, logos and designs described herein may in whole or in part be subject to intellectual property rights. Reproduction, use, modification or disclosure to third parties of this document or any part thereof without the express permission of u-blox is strictly prohibited.

The information contained herein is provided "as is". No warranty of any kind, either express or implied, is made in relation to the accuracy, reliability, fitness for a particular purpose or content of this document. This document may be revised by u-blox at any time. For most recent documents, please visit [www.u-blox.com](http://www.u-blox.com).  
Copyright © 2021, u-blox AG

### Further information

For contact information, see [www.u-blox.com/contact-u-blox](http://www.u-blox.com/contact-u-blox).

For more product details and ordering information, see the product data sheet.