

4

3

2

1

THIS DRAWING IS UNPUBLISHED. RELEASED FOR PUBLICATION 20  
 © COPYRIGHT 20 BY - ALL RIGHTS RESERVED.

REVISIONS				
P	LTR	DESCRIPTION	DATE	APVD
A		RELEASED FOR PRODUCTION	13SEP2017	RK OP
A1		REVISED PER ECR-19-008526	31MAY2019	SR DD
A2		ECR-20-017275	20JAN2021	JL MM

ZHAGA X-AXIS  
 ZHAGA Y-AXIS  
 Ø5.35  
 Ø30.00  
 Ø36.50±0.25

1.00  
 9.40±0.25  
 2.70  
 1.4  
 18.00 REF  
 27.40±0.30  
 Ø8.00  
 M20X1.5 THREAD

NOTES:

1 MATERIALS AND FINISH:  
 -RECEPTACLE HOUSING: PBT, COLOR: GREY  
 -NUT: NYLON, COLOR: BLACK  
 -CONTACTS: COPPER ALLOY, FINISH: Sn OVER Ni  
 -SEAL: SILICON, COLOR: BLACK  
 -STAR WASHER: STAINLESS STEEL

2. MUST COMPLY WITH DIRECTIVE 2002/95/EC (ROHS)

4 LOCK WASHER (REF P/N: 2213817-1) AND NUT (REF P/N: 2213791-1)  
 NOT ASSEMBLED, SHIPPED BULK PACKED

5 LOCK WASHER (REF P/N: 2213817-1) AND NUT (REF P/N: 2213791-1)  
 NOT INCLUDED

SCALE 5:2

SEE SHEET 2 FOR  
BOTTOM VIEW DETAIL

5 1-2213858-1  
 2213858-1  
 PART NO.

THIS DRAWING IS A CONTROLLED DOCUMENT.		DWN C. DAILY 05APR2016	TE Connectivity	
DIMENSIONS: mm		CHK E. HOWARD 05APR2016	NAME RECEPTACLE ASSEMBLY, LUMAWISE ENDURANCE S	
TOLERANCES UNLESS OTHERWISE SPECIFIED:		APVD -	PRODUCT SPEC 108-133073	
0 PLC ±		APVD -	APPLICATION SPEC 114-133074	
1 PLC ±0.2		APVD -	WEIGHT -	
2 PLC ±0.15		APVD -	CUSTOMER DRAWING	
3 PLC ±		APVD -	SCALE 3:1 SHEET 1 OF 2 REV A2	
4 PLC ±		APVD -		
ANGLES ±		APVD -		
FINISH ±2		APVD -		

1471-9 (3/13)

THIS DRAWING IS UNPUBLISHED. RELEASED FOR PUBLICATION 20  
 © COPYRIGHT 20 BY - ALL RIGHTS RESERVED.

REVISIONS				
P	LTR	DESCRIPTION	DATE	APVD
-	-	SEE SHEET 1	-	-

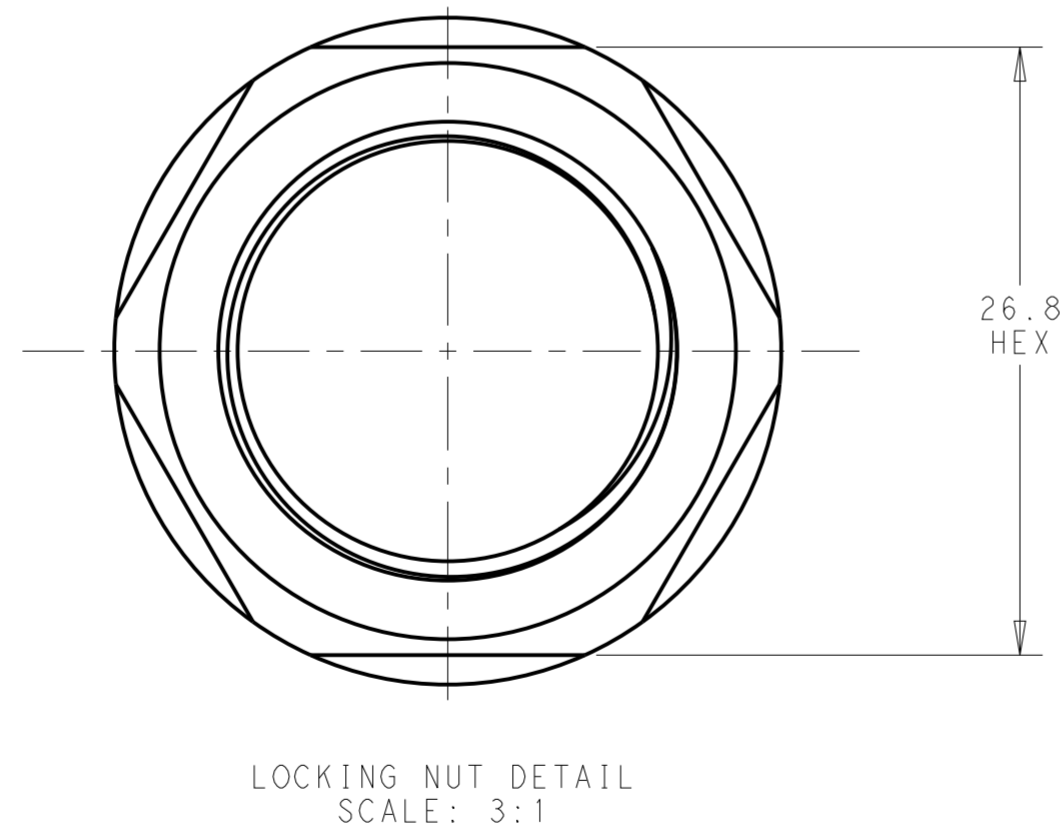
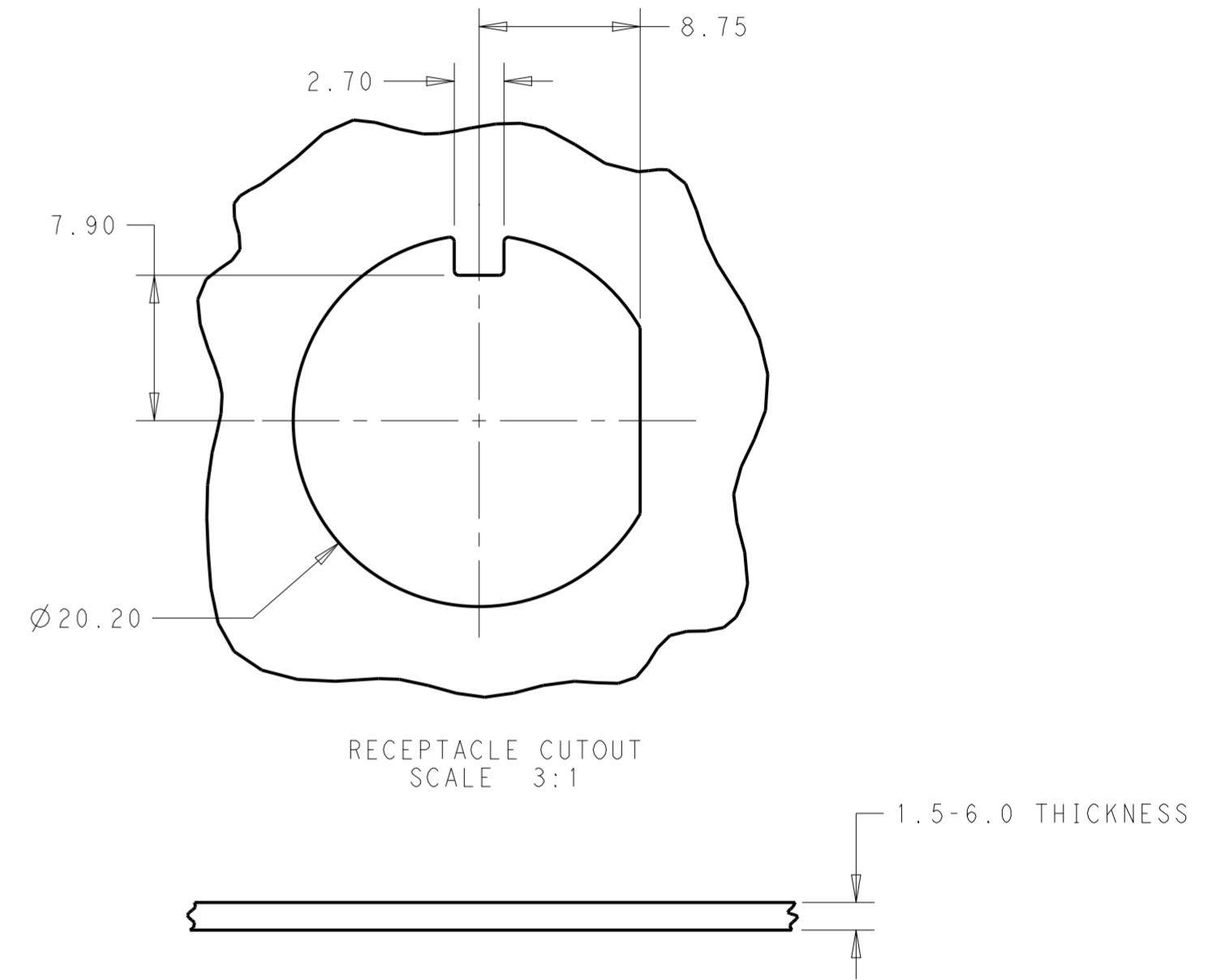
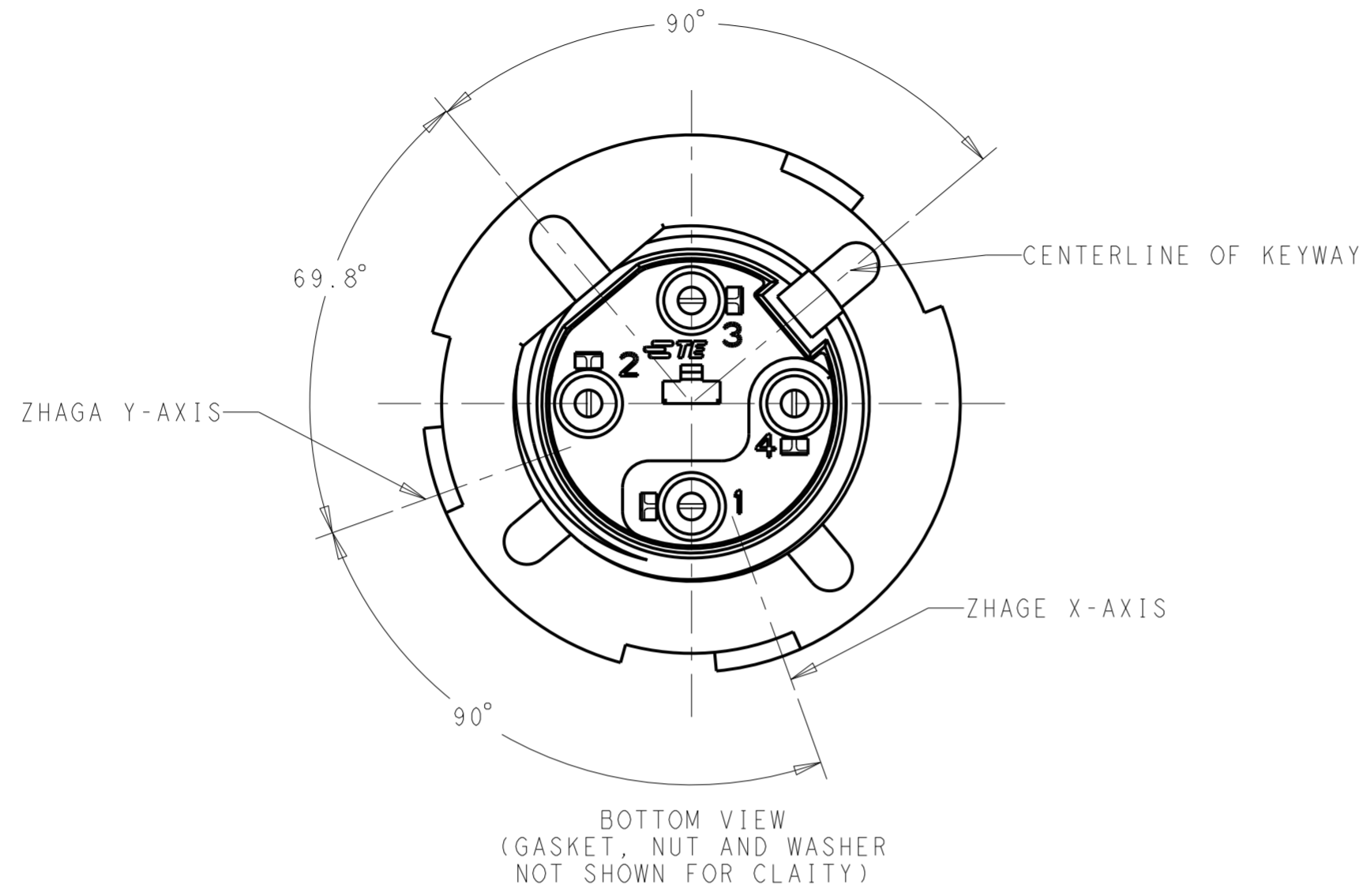

THIS DRAWING IS A CONTROLLED DOCUMENT.		DWN C. DAILY 05APR2016	<b>STE</b> TE Connectivity	
		CHK E. HOWARD 05APR2016		
DIMENSIONS: mm		APVD -	NAME RECEPTACLE ASSEMBLY, LUMAWISE ENDURANCE S	
TOLERANCES UNLESS OTHERWISE SPECIFIED:		PRODUCT SPEC 108-133073	SIZE A2	
0 PLC ±		APPLICATION SPEC 114-133074	CAGE CODE -	DRAWING NO C-2213858
1 PLC ±0.2		WEIGHT -	RESTRICTED TO -	
2 PLC ±0.15		CUSTOMER DRAWING	SCALE 3:1	SHEET 2 OF 2
3 PLC ±				REV A2
4 PLC ±				
ANGLES ±2				
FINISH				