

|     |              |            |
|-----|--------------|------------|
| NO. | MATERIAL NO. | ENG. NO.   |
| 1   | 355120200    | 35512-0200 |

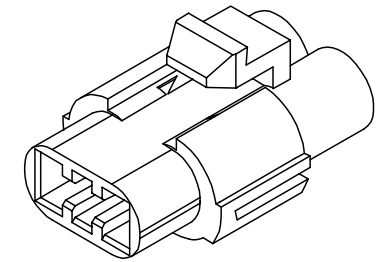

**ISOMETRIC VIEW**

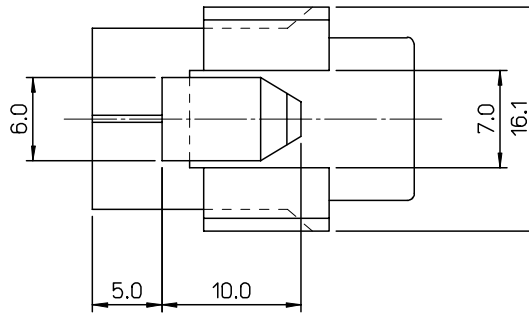
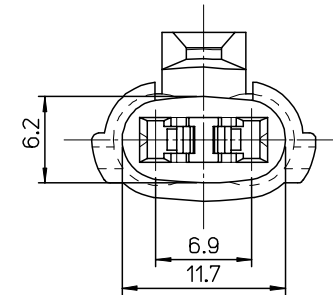
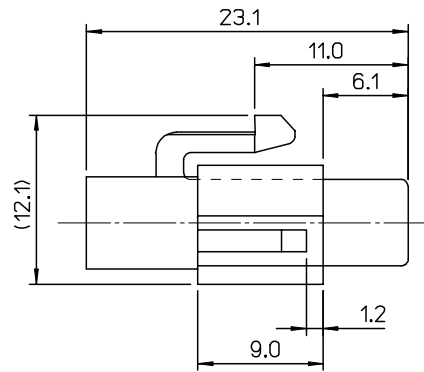
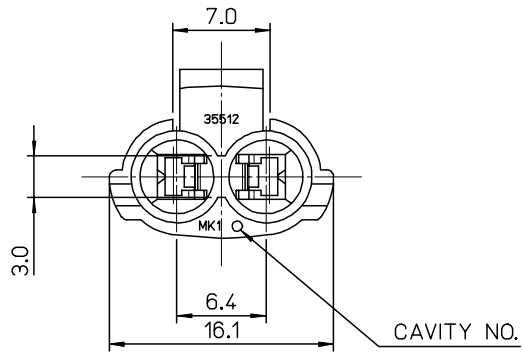

**NOTES**

1. MATERIAL : POLYAMIDE(PA66), 40% MINERAL FILLED, UL94HB

|   |                               |  |                      |                                   |                     |                                     |                        |                                     |  |
|---|-------------------------------|--|----------------------|-----------------------------------|---------------------|-------------------------------------|------------------------|-------------------------------------|--|
| CHANGED OF MATERIAL<br>E.C. NO.: KOR2008-0070<br>DRW: NEEKIM 2007/10/04<br>CHK: BCY00N 2007/10/04<br>APPR: YUNSIKKIM 2007/10/02 | QUALITY SYMBOLS<br>▽=0<br>▽=0 | GENERAL TOLERANCES (UNLESS SPECIFIED)                |                      | DIMENSION STYLE<br><b>MM ONLY</b> | SCALE<br><b>4:1</b> | DESIGN UNITS<br><b>METRIC</b>       | THIRD ANGLE PROJECTION |                                     |  |
|   |                               | 4 PLACES ± --- ± ---                                 | 3 PLACES ± --- ± --- | 2 PLACES ± --- ± ---              | 1 PLACE ± 0.3 ± --- | DRAWN BY: JKOH DATE: 1997/01/20     |                        | TITLE: STS FEMALE HOUSING 2P        |  |
|   |                               | ANGULAR ± 1 °  |                      |                                   |                     | CHECKED BY: BKCHOI DATE: 1997/01/20 |                        | APPROVED BY: CWLEE DATE: 1997/01/20 |  |
|   |                               | DRAFT WHERE APPLICABLE MUST REMAIN WITHIN DIMENSIONS |                      | MATERIAL NO.: 355120200           |                     | MOLEX INCORPORATED                  |                        | DOCUMENT NO.: SD-35512-001          |  |
|   |                               |  |                      | SIZE: A2                          |                     | SHEET NO.: 1 OF 1                   |                        |                                     |  |