

© - TE Connectivity. All Rights Reserved.

REVISIONS

P	LTR	DESCRIPTION	DATE	DWN	APVD
	K5	REVISED PER ECN-22-156403	03JUN2022	RK	CSD

AMP WIRE RANGE	Listed FILE E13288	LR7189 Certified
12-10 AWG SOLID OR STRANDED	12-10 AWG SOLID OR STRANDED	12-10 AWG SOLID OR STRANDED

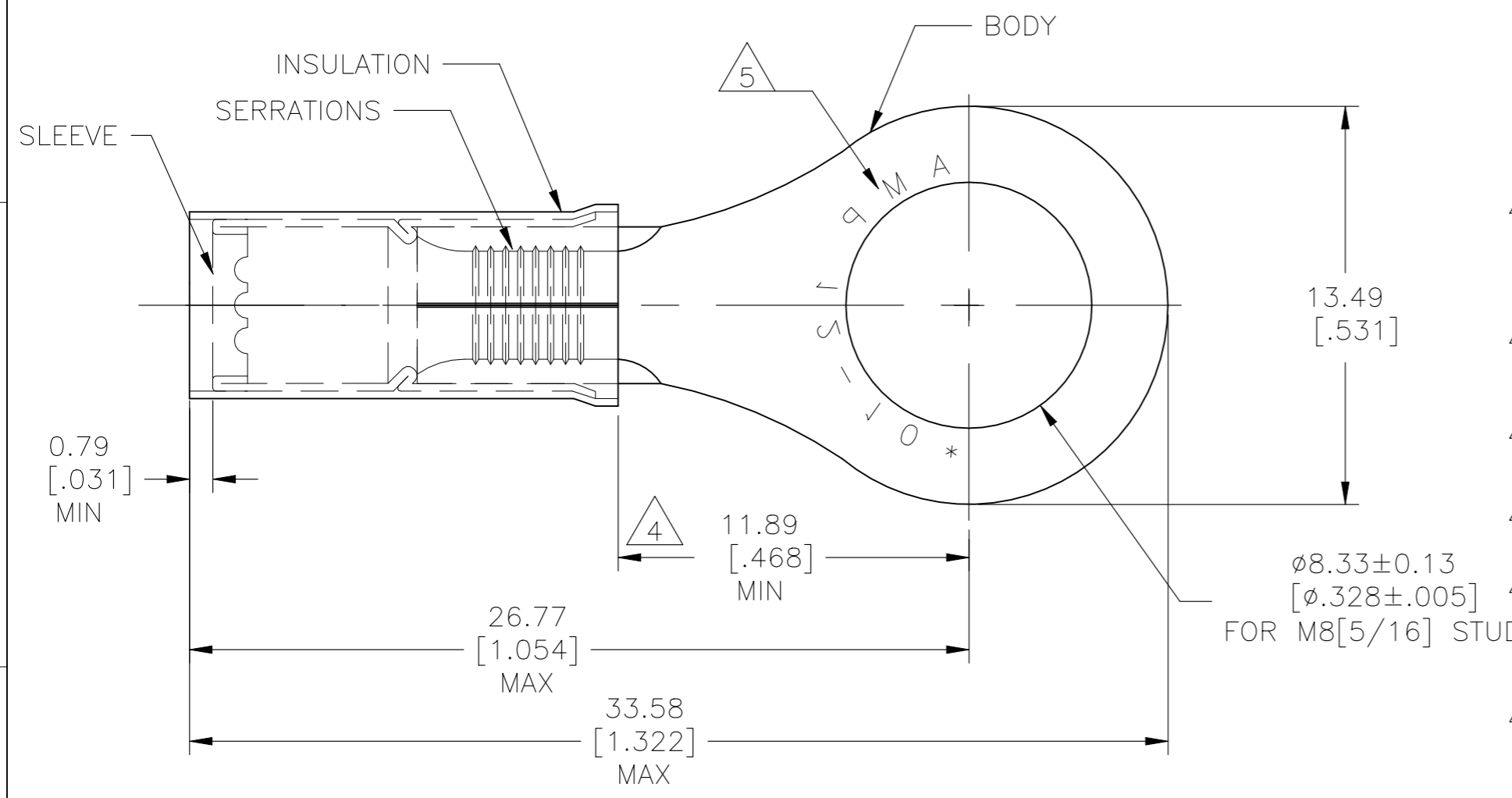

- 1 FOR WIRE INSULATION DIA: 3.81[.150] TO 6.35[.250]
- 2 TONGUE MATERIAL THK: 1.02±0.05[.040±.002]
- 3 ALTERNATE PVC INSULATION MATERIAL FOR FOREIGN SUBSIDIARIES ONLY.
- 4 DIMENSION APPLIES FROM EDGE OF METAL WIRE BARREL TO CENTER OF STUD HOLE.
- 5 STAMP AMP 12-10* APPROX AS SHOWN
- 6 MATERIAL:
BODY&SLEEVE: COPPER PER ASTM B152
INSULATION: NYLON. 3
- 7 FINISH:
BODY&SLEEVE: TIN PLATE PER ASTM B545
INSULATION: COLOR-YELLOW

-	100	LOOSE PC, BOX	8-35111-1
-	2500	ON TAPE, REEL	2-35111-1
MS25036-113 CLASS 1	500	LOOSE PIECE	35111
MILITARY PART NO& CLASS	QTY	PACKAGE TYPE	PART NO

AMP INCORPORATED
CUSTOMER SERVICE SYSTEMS

FOR ADDITIONAL PRODUCT INFORMATION OR COPIES OF DRAWINGS AND TECHNICAL DOCUMENTS	PRODUCT INFORMATION CENTER 1-800-522-6752	RECOMMENDED OPERATING TEMPERATURE: 105°C [221°F]
FOR APPLICATION TOOLING INFORMATION	TOOLING ASSISTANCE CENTER 1-800-722-1111	VOLTAGE RATING: 300V MAX
FOR ORDER ENTRY	1-800-526-5142	WIRE CROSS SECTIONAL AREA RANGE: 2.62-6.64mm ² [5,180-13,100] SOLID OR STRANDED

THIS DRAWING IS A CONTROLLED DOCUMENT.

DIMENSIONS: mm [INCHES]	TOLERANCES UNLESS OTHERWISE SPECIFIED:
	0 PLC ± -
	1 PLC ± -
	2 PLC ± 0.20[.008]
	3 PLC ± -
	4 PLC ± -
	ANGLES ± 5°
MATERIAL	FINISH
6	7

DWN	02APR12	KIRAN HOLAL
CHK	02APR12	ROHDE DANIEL
APVD	02APR12	ROHDE DANIEL
PRODUCT SPEC		
APPLICATION SPEC		
WEIGHT		-

TE Connectivity			
NAME WIRE TERMINAL P.I.D.G RING TONGUE WIRE SIZE: 12-10			
SIZE	CAGE CODE	DRAWING NO	RESTRICTED TO
A3	00779	C-35111	-
CUSTOMER DRAWING		SCALE 5:1	SHEET 1 OF 1 REV K5