

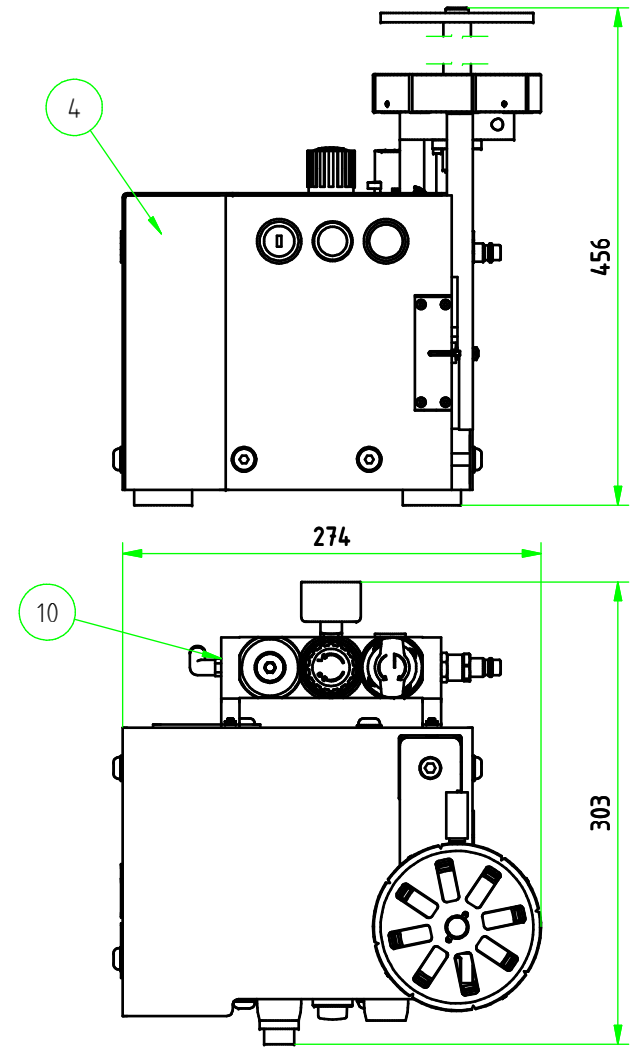

REVISIONS

P	LTR	DESCRIPTION	DATE	DWN	APVD
	B	INITIAL REVISION	18MAR16	LS	LB

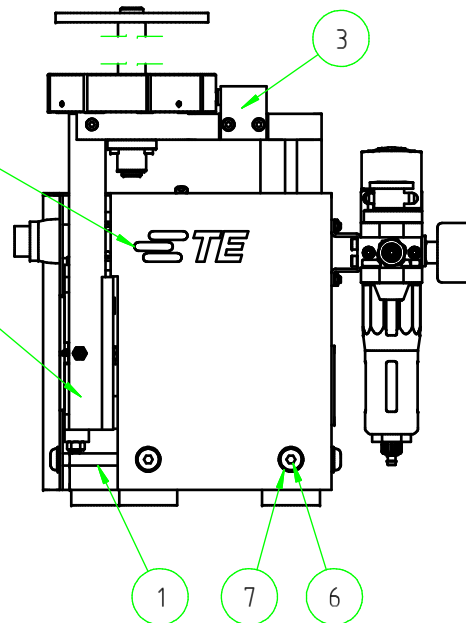
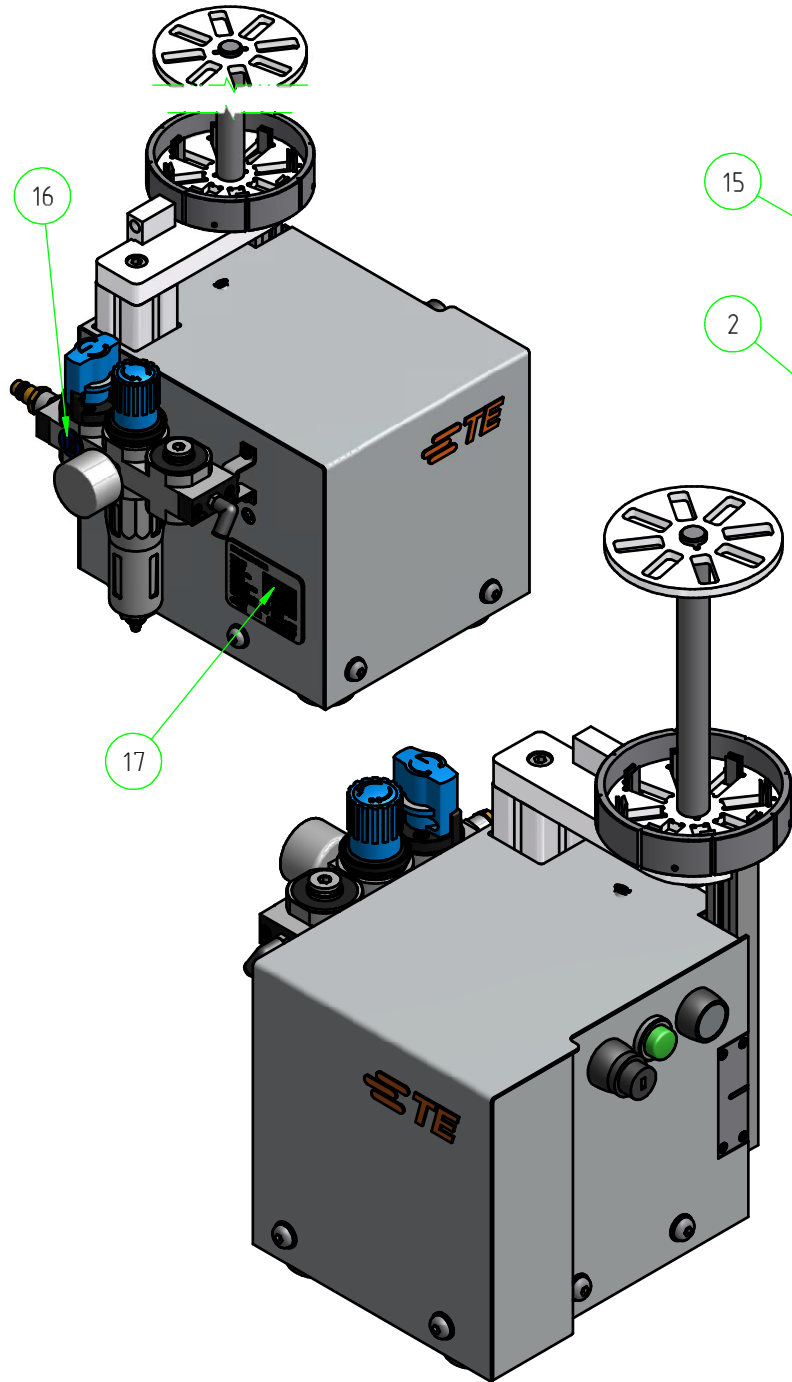

USED FOR CONNECTOR SYSTEM:
180 DEG IDC PLUG IN HE 1302/1402
Series,

TE 114-15031

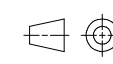
THIS DRAWING IS A CONTROLLED DOCUMENT.		DWN L.Sandhu 18MAR2016	 TE Connectivity			
DIMENSIONS: mm		CHK L.Sandhu 18MAR2016				
		APVD L. Bauer 18MAR2016	NAME BENCH PRESS HE14 180 DEGREE Tischpresse			
TOLERANCES UNLESS OTHERWISE SPECIFIED:		PRODUCT SPEC	SIZE A3	CAGE CODE 00779	DRAWING NO 949300-3	RESTRICTED TO
0 PLC ± 1 PLC ± 2 PLC ± 3 PLC ± 4 PLC ± ANGLES ±		APPLICATION SPEC	Gewicht / Weight in Kg 15		SCALE 1:3	SHEET 1 OF 2
MATERIAL		FINISH	CUSTOMER DRAWING		REV B	

