

AN-1572 Quick Start Guide for a 3 Amp Buck Regulator Using the LM5576 and LM25576

ABSTRACT

This application note provides an easy to use process to design a 3 Amp buck regulator using the LM5576 and LM25576 switching regulators.

Contents

1	Introduction	2
2	Quick Guide Design Worksheet	3

List of Figures

1	Application Schematic	2
---	-----------------------------	---

List of Tables

1	Bill of Materials	5
---	-------------------------	---

1 Introduction

The LM5576 and LM25576 switching regulators feature all of the functions necessary to implement an efficient high voltage buck regulator using a minimum of external components. These easy to use regulators include either a 42V (LM25576) or a 75V (LM5576) N-Channel buck switch with an output current capability of 3 Amps. The operating frequency is programmable from 50kHz up to 1MHz. Protection features include: current limit, thermal shutdown and remote shutdown capability. The device is available in a power enhanced TSSOP-20 package featuring an exposed die attach pad to aid thermal dissipation.

This step-by-step guide provides an easy to use process to quickly select the external components necessary to complete a design. More detailed information including theory of operation, design trade-offs and additional application guidance is available in the device datasheet. Shown below in Figure 1 is a complete schematic for a 3 Amp step-down DC-DC converter. Several external component values can be standardized for most applications. The input voltage range, output voltage and desired operating frequency dictate the remaining component values.

An Excel based spreadsheet derived from the guide is available on www.ti.com.

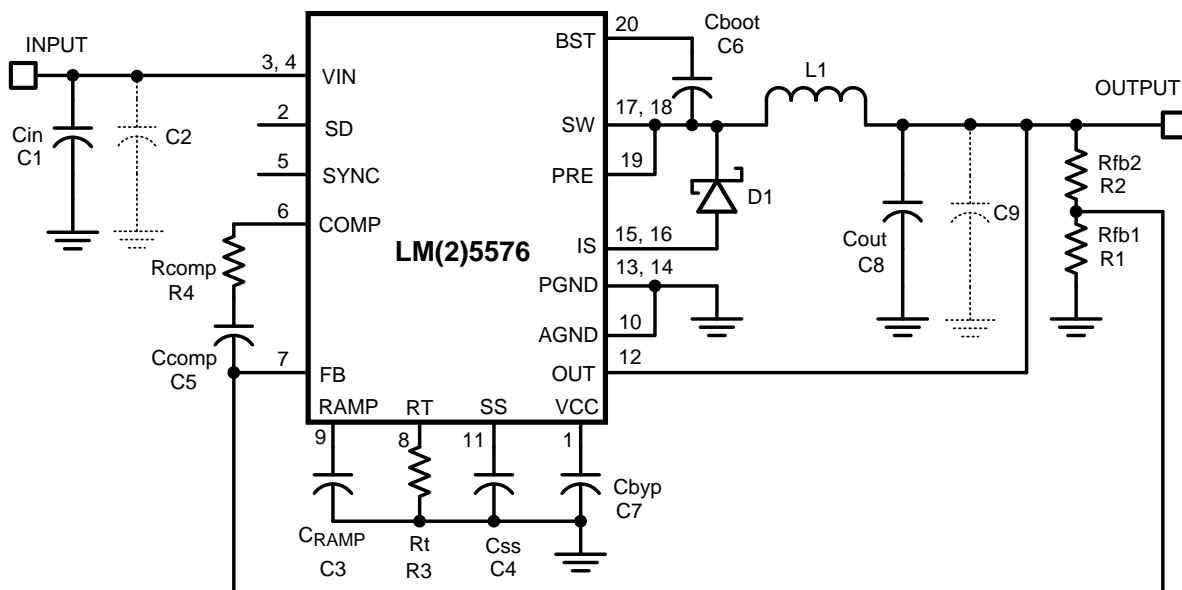

Figure 1. Application Schematic

2 Quick Guide Design Worksheet

Step 1. List the basic requirements:

Output Current: 0 to 3 Amp

Output Voltage: _____ V [1]

Input Voltage Min Spec: _____ V [2]

Input Voltage Max Spec: _____ V [3]

Step 2. If the Input Voltage Max Spec [3] is less than 42V use the LM25576. If the Input Voltage Max Spec [3] is greater than 42V but less than 75V use the LM5576. Both devices require the Input Voltage Min Spec [2] to be greater than 6V.

Selected Regulator: _____ [4]

Step 3. Selection of the operating frequency is a trade-off between the conversion efficiency and solution size. Operating at a high frequency, with a relatively high input voltage will severely impact the efficiency and consequently generate a lot of heat. In some applications, the selection of a high operating frequency will limit the input voltage range. The recommended maximum operating frequency for applications using LM5576 is 500 kHz. When using the LM25576 the operating frequency may be set as high as 1MHz. Select a target operating frequency from 50 kHz to 1MHz (500kHz for the LM5576). Check to see if the $V_{in(min)}$ limits the selected operating frequency:

$$F_{sw(max)} = \frac{V_{in(min)[2]} - (V_{out[1]} + 0.6)}{V_{in(min)[2]} \times 5.5 \times 10^{-7}} \quad (1)$$

The selected operating frequency must be less than $F_{sw(max)}$ calculated above, if not reduce the operating frequency. Check to see if the $V_{in(max)}$ limits the selected operating frequency:

$$F_{sw(max)} = \frac{(V_{out[1]} + 0.6)}{V_{in(max)[3]} \times 8 \times 10^{-8}} \quad (2)$$

The selected operating frequency must be less than $F_{sw(max)}$ calculated above, if not reduce the operating frequency.

Selected operating frequency _____ Hz [5]

Fsw: _____

Step 4. Calculate the value of R_t for the selected operating frequency.

$$R_t = \frac{\frac{1}{F_{sw[5]}} - 580 \times 10^{-9}}{135 \times 10^{-12}} \quad (3)$$

Selected value for R_1 : _____ Ohms [6]

Step 5. Calculate the value of L_1 .

$$L_1 = \frac{V_{out[1]} \times (V_{in(max)[3]} - V_{out[1]})}{0.8 \times F_{sw[6]} \times V_{in(max)[3]}} \quad (4)$$

Select the nearest standard inductor value. During an overload condition the peak inductor current is limited to 4.5A nominal (5.1A maximum). The selected inductor must be rated for peak current of at least 5.1 Amps.

Selected value of L_1 : _____ Henrys [7]

Step 6. Calculate the value of C_{RAMP} :

$$C_{RAMP} = L1[7] \times 10^{-5} \quad (5)$$

Selected value of C_{RAMP} : _____ Farads [8]

Step 7. Set Rfb2 to 5kOhms if Vout[1] is less than or equal to 5 Volts. If Vout[1] is greater than 5V set Rfb2 to 10K Ohms.

Selected value of Rfb2: _____ Ohms [9]

Calculate the value of Rfb1:

$$Rfb1 = \frac{1.225 \times Rfb2[9]}{(Vout[1] - 1.225)} \quad (6)$$

Selected value of Rfb1: _____ Ohms [10]

Step 8. Select the re-circulating diode, D1. A Schottky type diode is required for all applications. Ultra-fast diodes are not recommended and may result in damage to the IC due to reverse recovery current transients. The reverse breakdown rating should be greater than the Input Voltage Max Spec[3], plus some safety margin. For worst case design, assume a short circuit load condition. In this case the diode will carry the output current almost continuously. This current can be as high as 5.1A. Assuming a 0.6V drop across the diode, the maximum diode power dissipation can be as high as 3W. A DPAK or SMC case is recommended.

Selected diode part number: _____ [11]

Step 9. A good quality input capacitor(s) is necessary to limit the ripple voltage at the VIN pin while supplying most of the switch current during the on-time. The minimum RMS ripple current rating for the input capacitor(s) is 1.5Amp. A quality ceramic capacitor(s) with a low ESR is recommended. The input capacitor voltage rating should be greater than the Input Voltage Max Spec [3], plus some safety margin. A guide to select the input capacitor(s) value in proportion to the operating frequency is:

$$Cin = \frac{1.5}{Fsw[5]} \quad (7)$$

Selected value for Cin: _____ [12]

Farads:

Step 10. The output capacitor(s) smooth the inductor ripple current and provide a source of charge for transient loading conditions. A good starting point for the output capacitance is to parallel a ceramic capacitor (10 μ F to 47 μ F) and a low ESR organic or tantalum capacitor (22 μ F to 220 μ F). The ceramic capacitor provides ultra low ESR to reduce the output ripple voltage and noise spikes, while the larger bulk capacitor provides a source of charge for transient loading conditions. The output capacitor voltage rating should be greater than the Output Voltage Spec [1], plus some safety margin. An approximation for the output ripple voltage is:

$$\Delta V_{out} = 0.8 \times \left(ESR + \frac{1}{8 \times Fsw[5] \times Cout} \right) \quad (8)$$

Selected value for Cout: _____ Farads [13]

Step 11. Ccomp and Rcomp configure the error amplifier gain characteristics to accomplish a stable overall loop gain. One advantage of current mode control is the ability to close the loop with only two feedback components. Calculate the value of Rcomp:

$$R_{comp} = 6 \times 10^4 \times R_{fb1}[9] \times C_{out}[13] + \left(\frac{R_{fb1}[9]}{V_{out}[1]} \right) \quad (9)$$

Selected value of Rcomp: _____ Ohms [14]

Calculate the value of Ccomp

$$C_{comp} = \frac{1}{8 \times 10^3 \times R_{comp}[14]} \quad (10)$$

Selected value of Ccomp: _____ Farads [15]

Step 12. Shown in [Table 1](#) is the Bill of Materials for your design. Transcribe each value [#] from worksheet above into the following table. Congratulations, you're done.

2.1 Bill of Materials

Table 1. Bill of Materials

SCH REF	PART NUMBER	DESCRIPTION	VALUE	WORK SHEET REF
C1 (Cin)		INPUT CAPACITOR		[12]
C2 (Cin)		OPTIONAL INPUT CAPACITOR		[12]
C3 (C _{RAMP})		RAMP CAPACITOR		[8]
C4 (C _{ss})	C2012X7R2A103K	CAPACITOR, TDK	0.01μ, 100V	--
C5 (C _{comp})		COMPENSATION CAP		[15]
C6 (C _{boot})	C2012X7R2A223K	CAPACITOR, TDK	0.047μ, 100V	--
C7 (C _{byp})	C2012X7R1C474M	CAPACITOR, TDK	0.47μ, 16V	--
C8 (C _{out})		OUTPUT CAPACITOR		[13]
C9 (C _{out})		OPTIONAL OUTPUT CAPACITOR		[13]
D1		SCHOTTKY DIODE		[11]
L1		INDUCTOR		[7]
R1 (R _{fb1})		Feedback RESISTOR		[10]
R2 (R _{fb2})		Feedback RESISTOR		[9]
R3 (R _t)		TIMING RESISTOR		[6]
R4 (R _{comp})		COMPENSATION RESISTOR		[14]
U1		REGULATOR, TI		[4]

IMPORTANT NOTICE

Texas Instruments Incorporated and its subsidiaries (TI) reserve the right to make corrections, enhancements, improvements and other changes to its semiconductor products and services per JESD46, latest issue, and to discontinue any product or service per JESD48, latest issue. Buyers should obtain the latest relevant information before placing orders and should verify that such information is current and complete. All semiconductor products (also referred to herein as "components") are sold subject to TI's terms and conditions of sale supplied at the time of order acknowledgment.

TI warrants performance of its components to the specifications applicable at the time of sale, in accordance with the warranty in TI's terms and conditions of sale of semiconductor products. Testing and other quality control techniques are used to the extent TI deems necessary to support this warranty. Except where mandated by applicable law, testing of all parameters of each component is not necessarily performed.

TI assumes no liability for applications assistance or the design of Buyers' products. Buyers are responsible for their products and applications using TI components. To minimize the risks associated with Buyers' products and applications, Buyers should provide adequate design and operating safeguards.

TI does not warrant or represent that any license, either express or implied, is granted under any patent right, copyright, mask work right, or other intellectual property right relating to any combination, machine, or process in which TI components or services are used. Information published by TI regarding third-party products or services does not constitute a license to use such products or services or a warranty or endorsement thereof. Use of such information may require a license from a third party under the patents or other intellectual property of the third party, or a license from TI under the patents or other intellectual property of TI.

Reproduction of significant portions of TI information in TI data books or data sheets is permissible only if reproduction is without alteration and is accompanied by all associated warranties, conditions, limitations, and notices. TI is not responsible or liable for such altered documentation. Information of third parties may be subject to additional restrictions.

Resale of TI components or services with statements different from or beyond the parameters stated by TI for that component or service voids all express and any implied warranties for the associated TI component or service and is an unfair and deceptive business practice. TI is not responsible or liable for any such statements.

Buyer acknowledges and agrees that it is solely responsible for compliance with all legal, regulatory and safety-related requirements concerning its products, and any use of TI components in its applications, notwithstanding any applications-related information or support that may be provided by TI. Buyer represents and agrees that it has all the necessary expertise to create and implement safeguards which anticipate dangerous consequences of failures, monitor failures and their consequences, lessen the likelihood of failures that might cause harm and take appropriate remedial actions. Buyer will fully indemnify TI and its representatives against any damages arising out of the use of any TI components in safety-critical applications.

In some cases, TI components may be promoted specifically to facilitate safety-related applications. With such components, TI's goal is to help enable customers to design and create their own end-product solutions that meet applicable functional safety standards and requirements. Nonetheless, such components are subject to these terms.

No TI components are authorized for use in FDA Class III (or similar life-critical medical equipment) unless authorized officers of the parties have executed a special agreement specifically governing such use.

Only those TI components which TI has specifically designated as military grade or "enhanced plastic" are designed and intended for use in military/aerospace applications or environments. Buyer acknowledges and agrees that any military or aerospace use of TI components which have **not** been so designated is solely at the Buyer's risk, and that Buyer is solely responsible for compliance with all legal and regulatory requirements in connection with such use.

TI has specifically designated certain components as meeting ISO/TS16949 requirements, mainly for automotive use. In any case of use of non-designated products, TI will not be responsible for any failure to meet ISO/TS16949.

Products

Audio	www.ti.com/audio
Amplifiers	amplifier.ti.com
Data Converters	dataconverter.ti.com
DLP® Products	www.dlp.com
DSP	dsp.ti.com
Clocks and Timers	www.ti.com/clocks
Interface	interface.ti.com
Logic	logic.ti.com
Power Mgmt	power.ti.com
Microcontrollers	microcontroller.ti.com
RFID	www.ti-rfid.com
OMAP Applications Processors	www.ti.com/omap
Wireless Connectivity	www.ti.com/wirelessconnectivity

Applications

Automotive and Transportation	www.ti.com/automotive
Communications and Telecom	www.ti.com/communications
Computers and Peripherals	www.ti.com/computers
Consumer Electronics	www.ti.com/consumer-apps
Energy and Lighting	www.ti.com/energy
Industrial	www.ti.com/industrial
Medical	www.ti.com/medical
Security	www.ti.com/security
Space, Avionics and Defense	www.ti.com/space-avionics-defense
Video and Imaging	www.ti.com/video

TI E2E Community

e2e.ti.com