

**NOTES:**

1. MATERIAL:  
RECEPTACLE HOUSING: PBT POLYESTER. COLOR: BLACK, UL94-V0
2. PACKAGING SPECIFICATION : 2155116121-PK
3. PRODUCT SPECIFICATION: 2155100006-PS
4. APPLICATION SPECIFICATION: 2155101000-AS
5. TEST SUMMARY : 2155106000-TS
6. ASSEMBLY MEETS ROHS REQUIREMENT.
7. MATES WITH MOLEX R/A HEADER ASSEMBLY 215510-6031(SCREW MOUNT) AND 215510-6241(SOLDER VERSION).
8. SHEET 2 & 3 ILLUSTRATE ASSEMBLY VIEWS AND IT IS FOR VISUAL PURPOSE ONLY

THIS DRAWING CONTAINS INFORMATION THAT IS PROPRIETARY TO MOLEX ELECTRONIC TECHNOLOGIES, LLC AND SHOULD NOT BE USED WITHOUT WRITTEN PERMISSION

DIMENSION UNITS	SCALE	CURRENT REV DESC:	molex				
mm	4:1	DRAWING UPDATED WITH NEW VIEW IN SHEET 4 TO ILLUSTRATE THE PANEL MOUNTING WITH SHOULDER SCREW AND NUT IN SHEET 4	2CKT 6MM PANEL MOUNT RECEPTACLE HOUSING POWERWIZE PRODUCT FAMILY				
GENERAL TOLERANCES (UNLESS SPECIFIED)		EC NO: 745616	PRODUCT CUSTOMER DRAWING				
ANGULAR TOL	± 0.5°	DRWN: CHETAB 2023/03/15	DOCUMENT NUMBER	DOC TYPE	DOC PART	REVISION	
4 PLACES	±	CHK'D: GSHARMA 2023/04/28	2155116121	PSD	000	A3	
3 PLACES	±	APPR: HTHYAGARAJ 2023/05/05					
2 PLACES	± 0.15	INITIAL REVISION:					
1 PLACE	± 0.25	DRWN: MBELLE 2020/03/30					
0 PLACES	±	APPR: HTHYAGARAJ 2021/11/05					
DRAFT WHERE APPLICABLE MUST REMAIN WITHIN DIMENSIONS		THIRD ANGLE PROJECTION	DRAWING	SERIES	MATERIAL NUMBER	CUSTOMER	SHEET NUMBER
			D-SIZE	215511	2155116121	GENERAL MARKET	1 OF 4

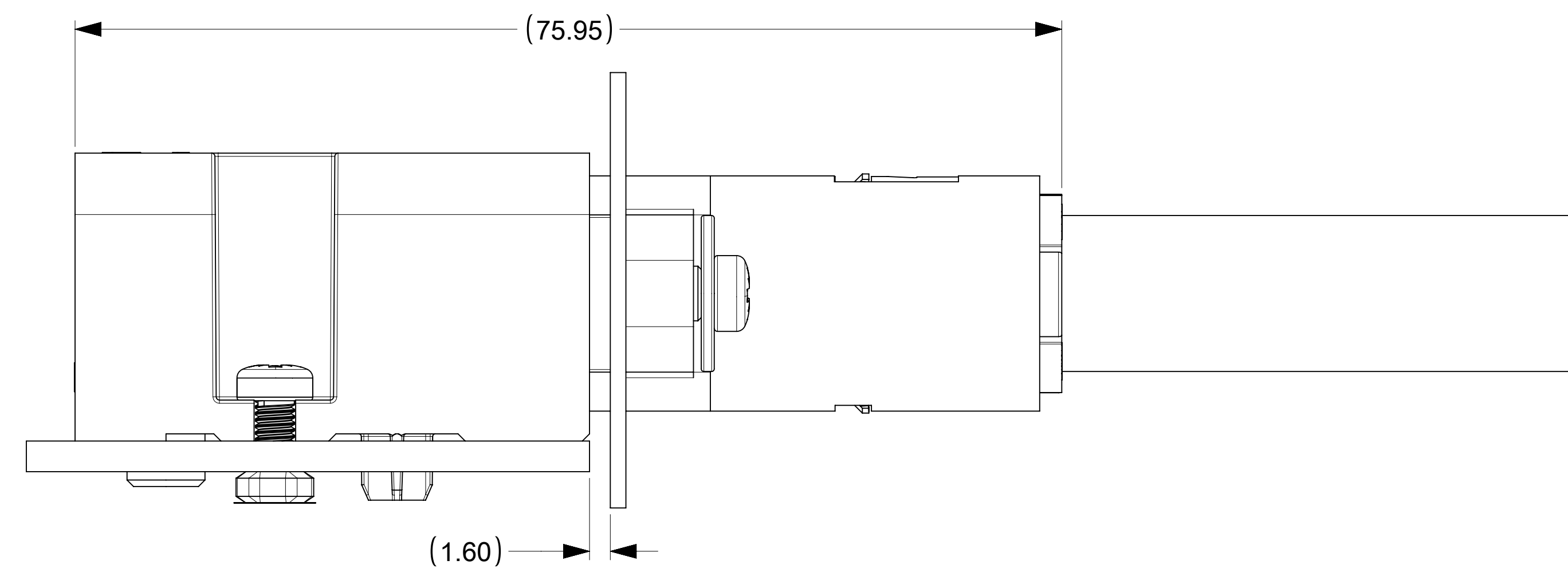
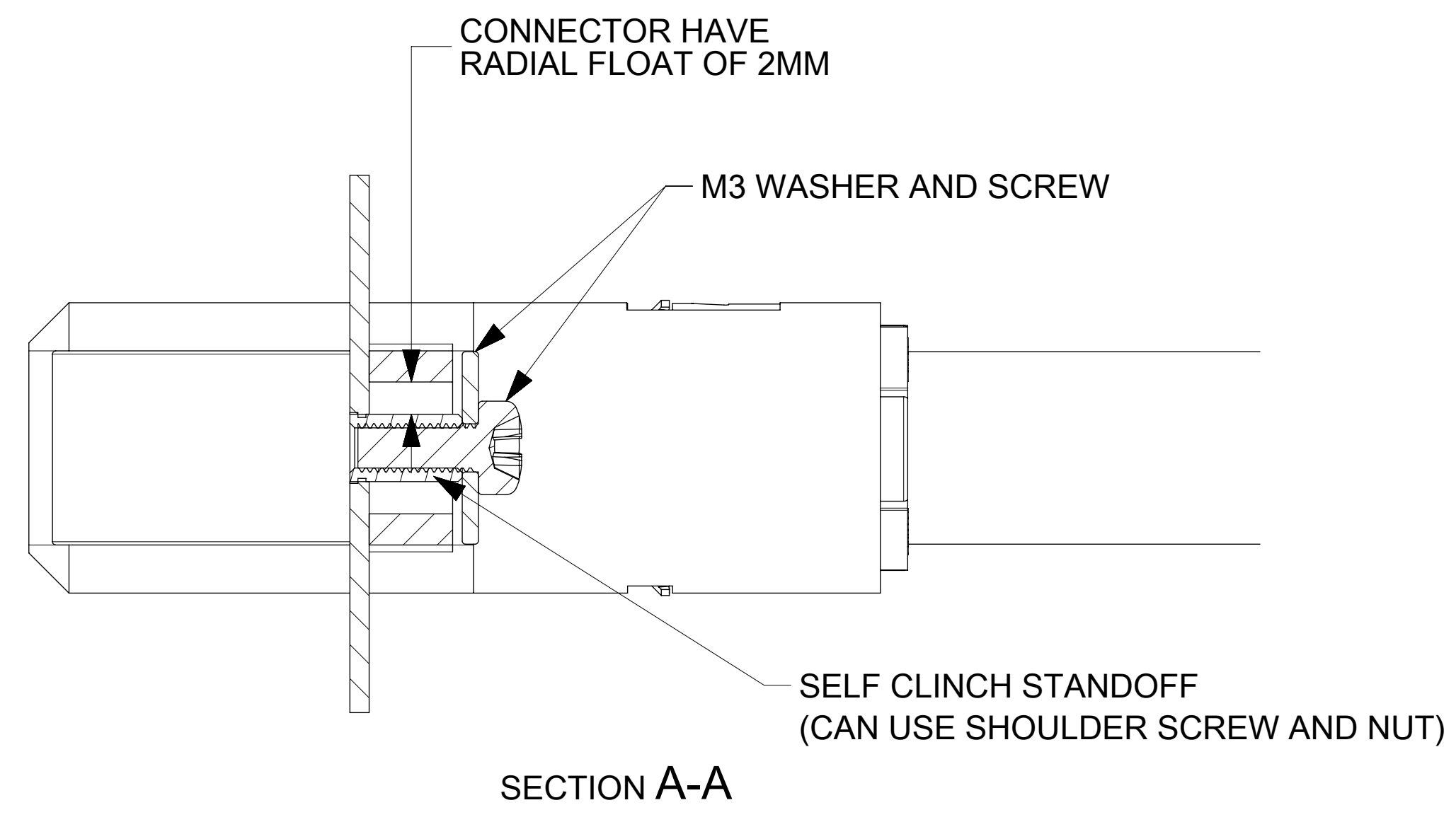
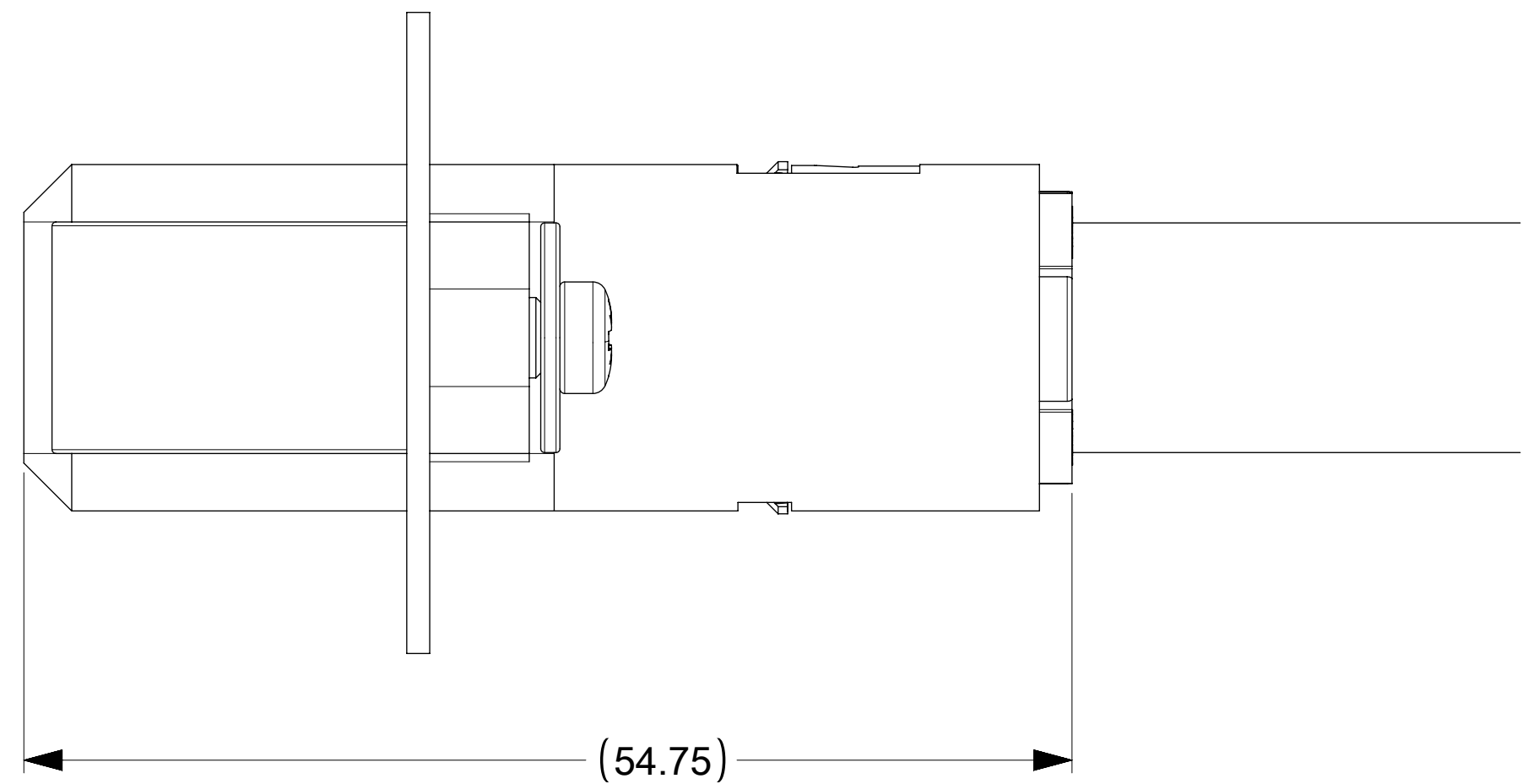
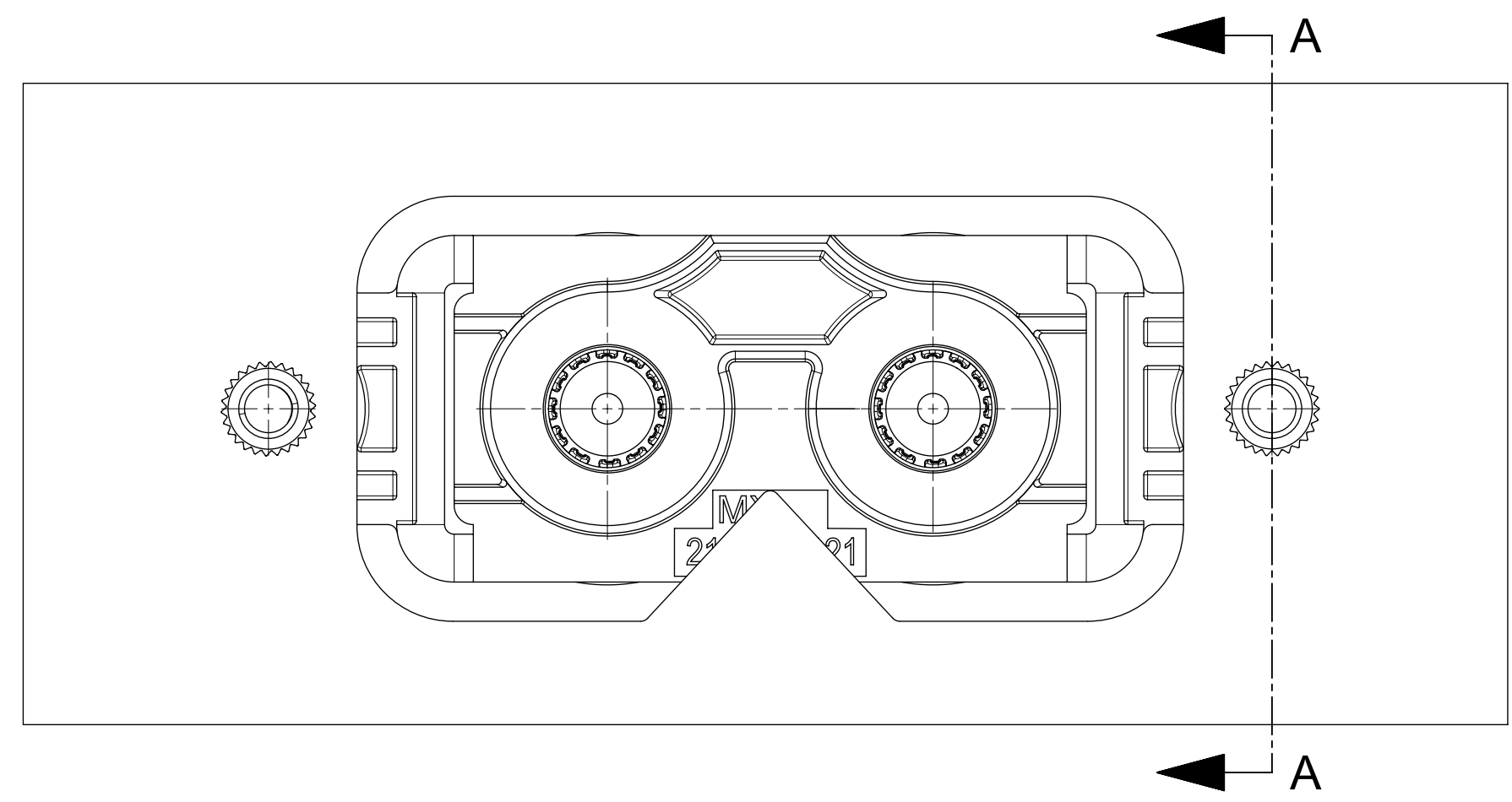

ASSEMBLED AND MATED WITH  
RA HEADER\_SOLDER TAIL VERSION (2155106241)

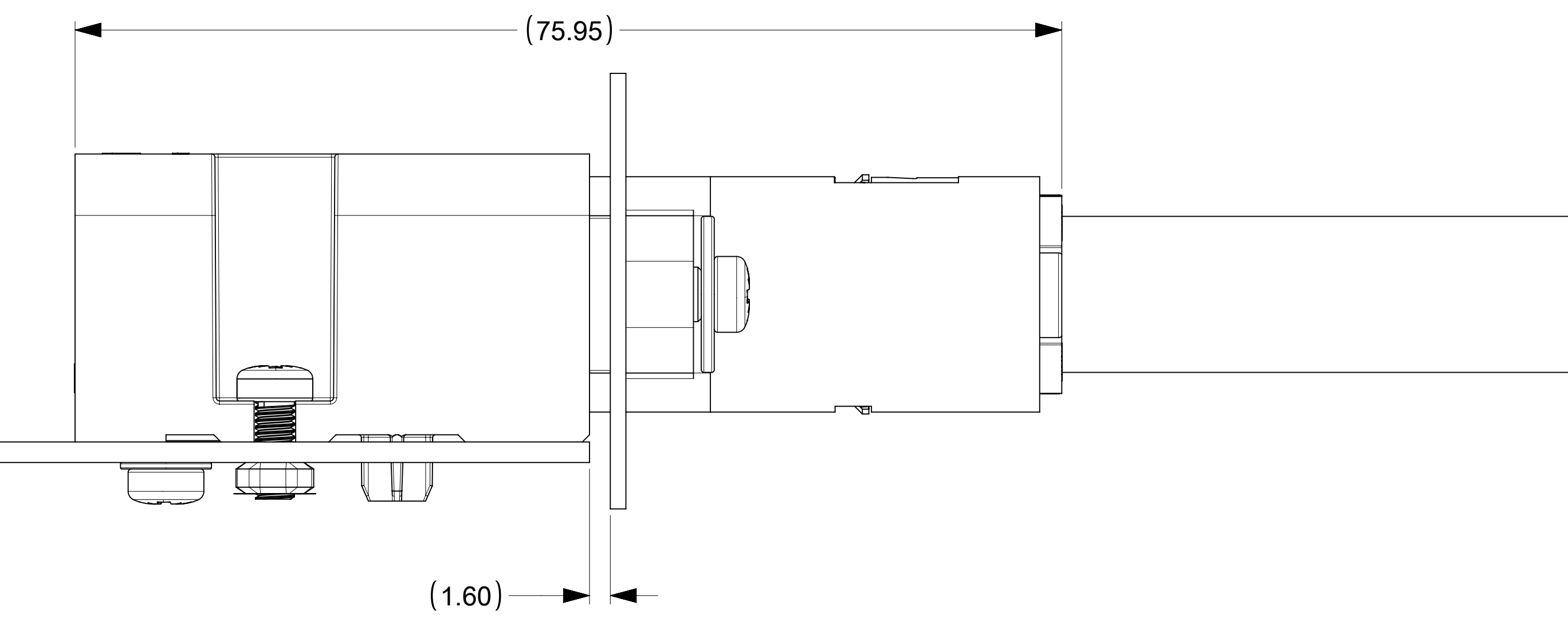

ASSEMBLED AND MATED WITH  
RA HEADER\_SCREW MOUNT VERSION (2155106031)

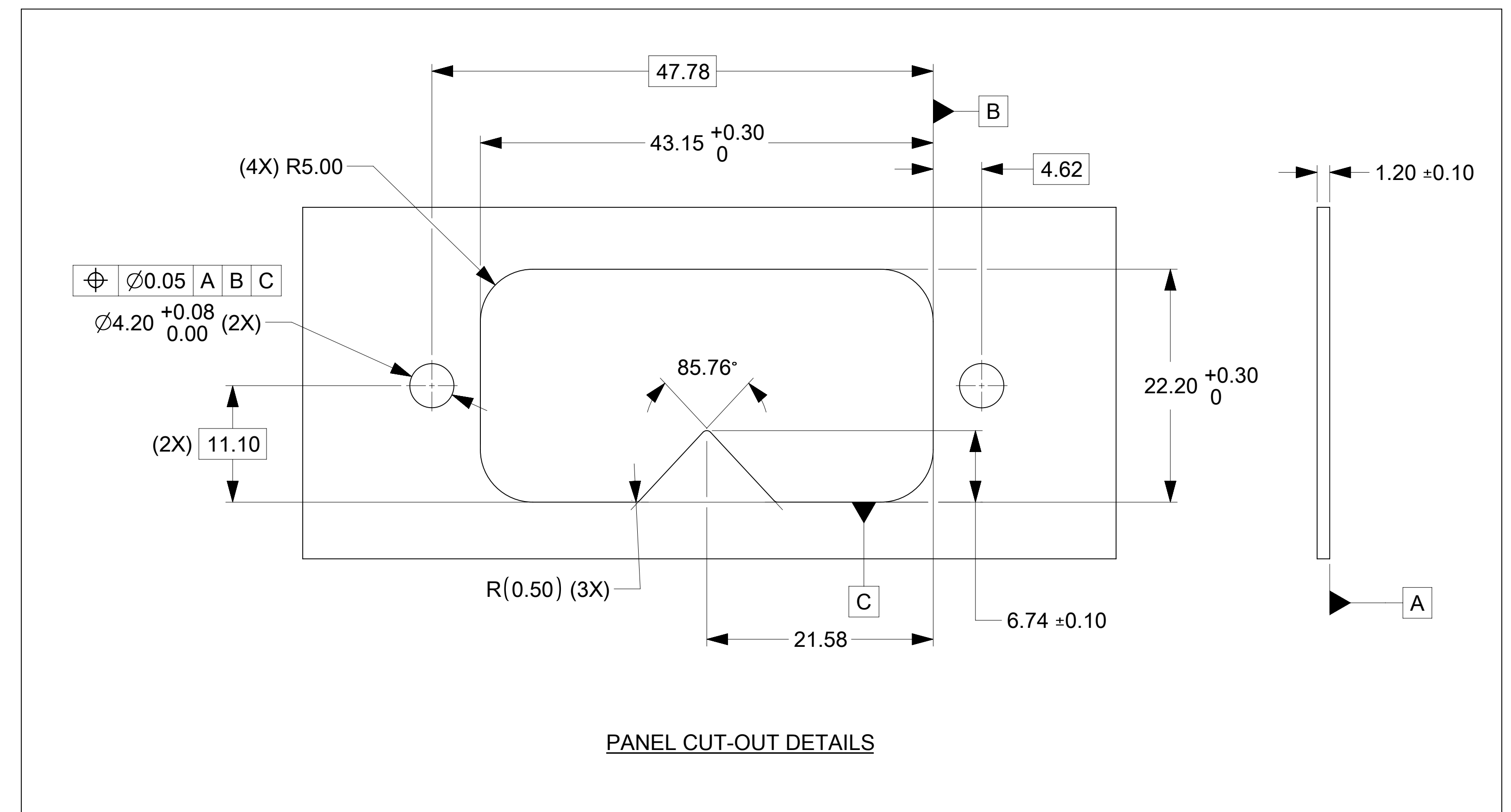

PANEL CUT-OUT DETAILS

THIS DRAWING CONTAINS INFORMATION THAT IS PROPRIETARY TO MOLEX ELECTRONIC TECHNOLOGIES, LLC AND SHOULD NOT BE USED WITHOUT WRITTEN PERMISSION									
DIMENSION UNITS <b>mm</b>		SCALE <b>3:1</b>		CURRENT REV DESC: DRAWING UPDATED WITH NEW VIEW IN SHEET 4 TO ILLUSTRATE THE PANEL MOUNTING WITH SHOULDER SCREW AND NUT IN SHEET 4					
GENERAL TOLERANCES (UNLESS SPECIFIED)				EC NO: 745616					
ANGULAR TOL ± 0.5°				4 PLACES ±		DRWN: CHETAB		2023/03/15	
3 PLACES ±				3 PLACES ±		CHK'D: GSHARMA		2023/04/28	
2 PLACES ± 0.15				2 PLACES ±		APPR: HTHYAGARAJ		2023/05/05	
1 PLACE ± 0.25				1 PLACE ±		INITIAL REVISION:		DRWN: MBELLE	
0 PLACES ±				0 PLACES ±		APPR: HTHYAGARAJ		2020/03/30	
DRAFT WHERE APPLICABLE MUST REMAIN WITHIN DIMENSIONS				THIRD ANGLE PROJECTION		DRAWING		SERIES	
				D-SIZE		215511		MATERIAL NUMBER	
								2155116121	
								CUSTOMER	
								GENERAL MARKET	
								SHEET NUMBER	
								2 OF 4	

**molex**

2CKT 6MM PANEL MOUNT RECEPTACLE HOUSING  
POWERWIZE PRODUCT FAMILY

PRODUCT CUSTOMER DRAWING

DOCUMENT NUMBER	DOC TYPE	DOC PART	REVISION
2155116121	PSD	000	A3

**PANEL MOUNT OF RECEPTACLE ASSEMBLY WITH SCREW AND SELF CLINCHING STANDOFF**

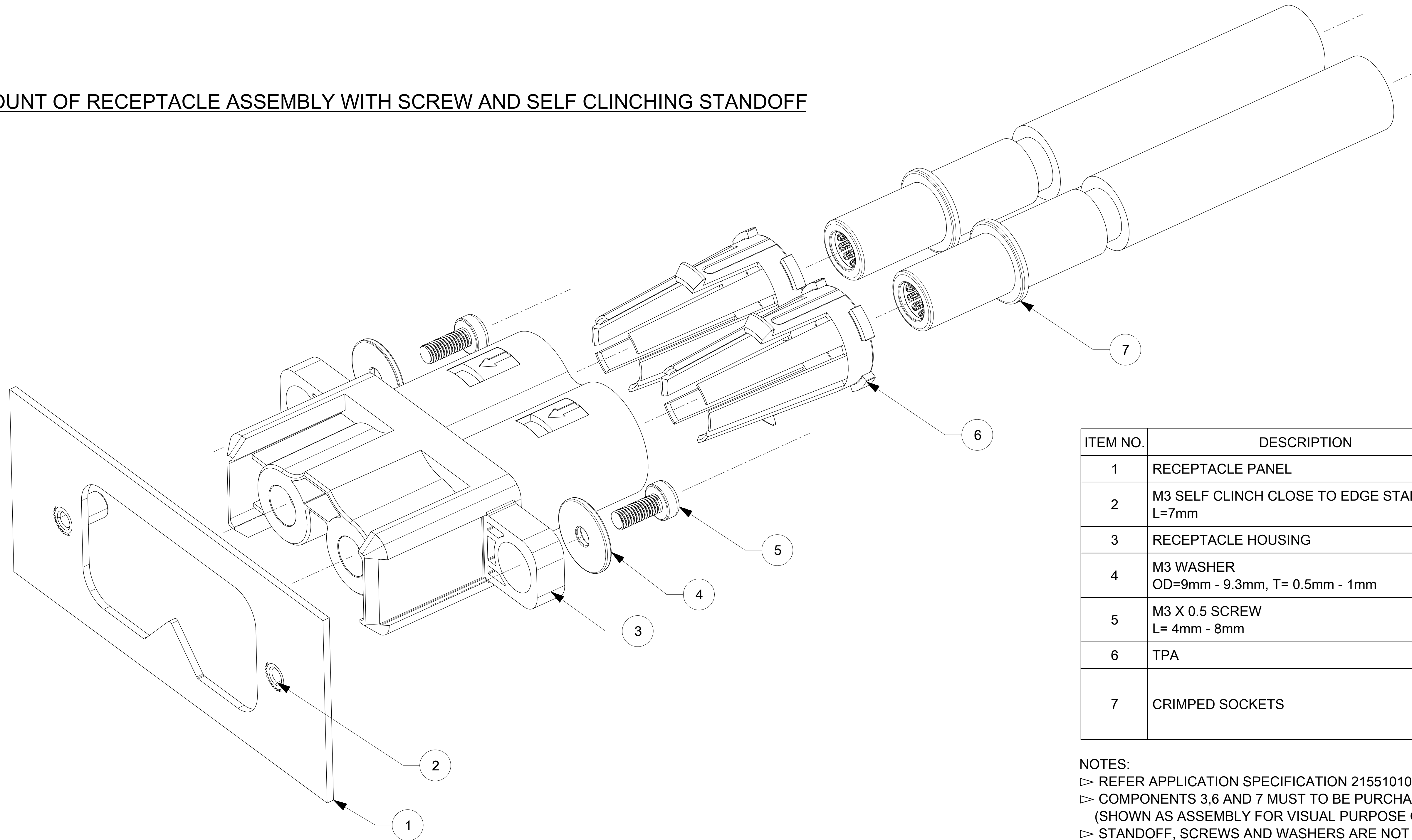

ITEM NO.	DESCRIPTION	QTY	REMARKS
1	RECEPTACLE PANEL	1	--
2	M3 SELF CLINCH CLOSE TO EDGE STANDOFF L=7mm	2	--
3	RECEPTACLE HOUSING	1	--
4	M3 WASHER OD=9mm - 9.3mm, T= 0.5mm - 1mm	2	--
5	M3 X 0.5 SCREW L= 4mm - 8mm	2	--
6	TPA	2	REFER SD: 2155136001
7	CRIMPED SOCKETS	2	WIRE SIZE : 2AWG,4AWG, 6AWG,8AWG & 10AWG REFER 2046080000-SD

- NOTES:
- ▷ REFER APPLICATION SPECIFICATION 2155101000-AS FOR INSTALLATION INSTRUCTION
  - ▷ COMPONENTS 3,6 AND 7 MUST TO BE PURCHASED INDIVIDUALLY  
(SHOWN AS ASSEMBLY FOR VISUAL PURPOSE ONLY)
  - ▷ STANDOFF, SCREWS AND WASHERS ARE NOT SUPPLIED BY MOLEX.
  - ▷ FOR MORE FASTENER DETAILS AND PANEL MOUNTING OPTIONS REFER 2155101000-AS

THIS DRAWING CONTAINS INFORMATION THAT IS PROPRIETARY TO MOLEX ELECTRONIC TECHNOLOGIES, LLC AND SHOULD NOT BE USED WITHOUT WRITTEN PERMISSION			
DIMENSION UNITS <b>mm</b>	SCALE <b>3:1</b>	CURRENT REV DESC: DRAWING UPDATED WITH NEW VIEW IN SHEET 4 TO ILLUSTRATE THE PANEL MOUNTING WITH SHOULDER SCREW AND NUT IN SHEET 4	
GENERAL TOLERANCES (UNLESS SPECIFIED)		 <b>2CKT 6MM PANEL MOUNT RECEPTACLE HOUSING POWERWIZE PRODUCT FAMILY</b> PRODUCT CUSTOMER DRAWING	
ANGULAR TOL	± 0.5°		
4 PLACES	±		
3 PLACES	±		
2 PLACES	± 0.15		
1 PLACE	± 0.25	EC NO: 745616	2023/03/15
0 PLACES	±	DRWN: CHETAB	2023/04/28
DRAFT WHERE APPLICABLE MUST REMAIN WITHIN DIMENSIONS		APPR: HTHYAGARAJ	2023/05/05
THIRD ANGLE PROJECTION		INITIAL REVISION:	
DRAWING		DRWN: MBELLE	2020/03/30
SERIES		APPR: HTHYAGARAJ	2021/11/05
D-SIZE		215511	
MATERIAL NUMBER		2155116121	
CUSTOMER		GENERAL MARKET	
SHEET NUMBER		3 OF 4	

**PANEL MOUNT OF RECEPTACLE ASSEMBLY WITH SHOULDER SCREW AND NUT**

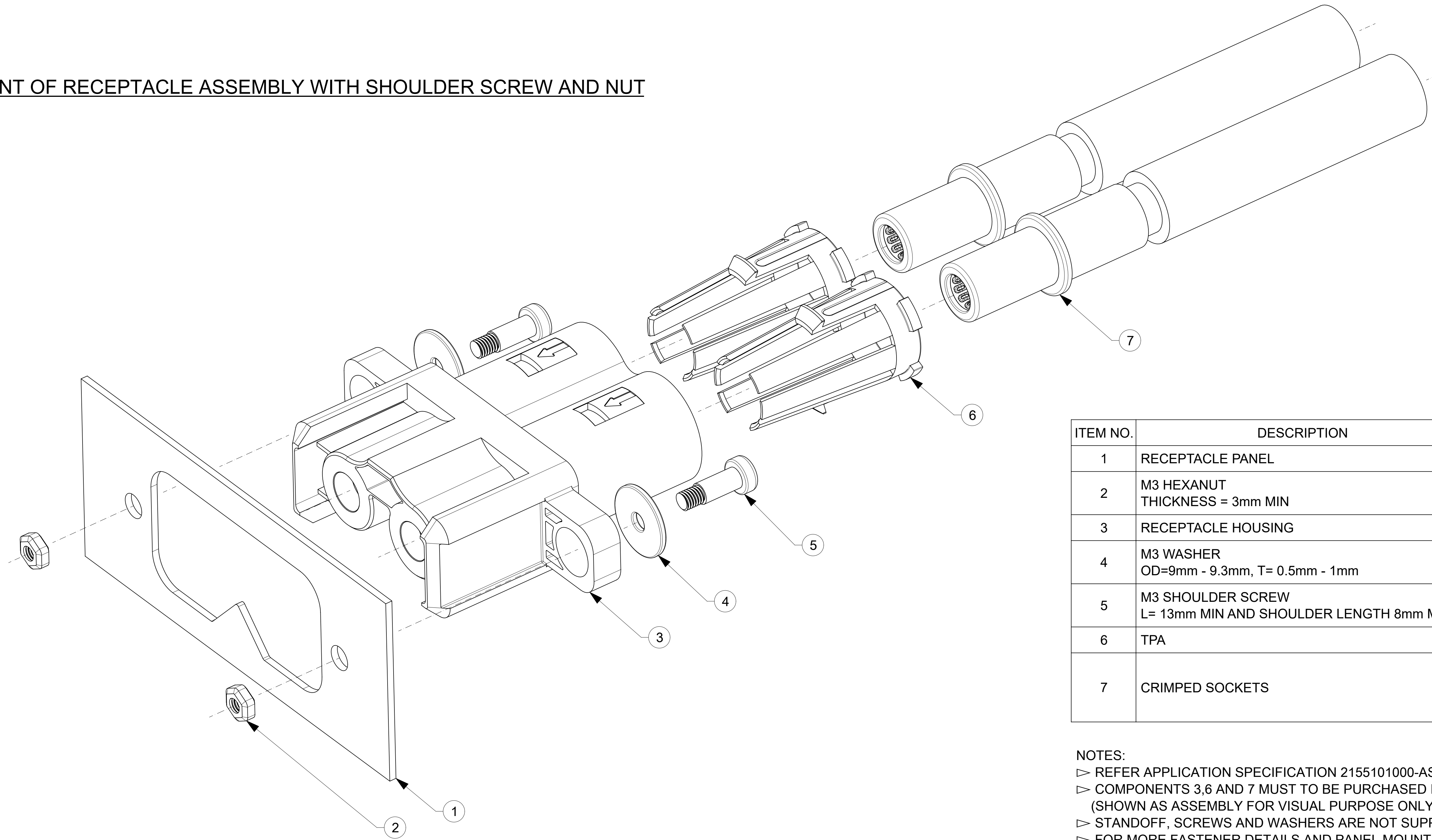

ITEM NO.	DESCRIPTION	QTY	REMARKS
1	RECEPTACLE PANEL	1	--
2	M3 HEXANUT THICKNESS = 3mm MIN	2	--
3	RECEPTACLE HOUSING	1	--
4	M3 WASHER OD=9mm - 9.3mm, T= 0.5mm - 1mm	2	--
5	M3 SHOULDER SCREW L= 13mm MIN AND SHOULDER LENGTH 8mm MIN	2	--
6	TPA	2	REFER SD: 2155136001
7	CRIMPED SOCKETS	2	WIRE SIZE : 2AWG,4AWG, 6AWG,8AWG & 10AWG REFER 2046080000-SD

**NOTES:**

- ▷ REFER APPLICATION SPECIFICATION 2155101000-AS FOR INSTALLATION INSTRUCTION
- ▷ COMPONENTS 3,6 AND 7 MUST TO BE PURCHASED INDIVIDUALLY  
(SHOWN AS ASSEMBLY FOR VISUAL PURPOSE ONLY)
- ▷ STANDOFF, SCREWS AND WASHERS ARE NOT SUPPLIED BY MOLEX.
- ▷ FOR MORE FASTENER DETAILS AND PANEL MOUNTING OPTIONS REFER 2155101000-AS

THIS DRAWING CONTAINS INFORMATION THAT IS PROPRIETARY TO MOLEX ELECTRONIC TECHNOLOGIES, LLC AND SHOULD NOT BE USED WITHOUT WRITTEN PERMISSION											
DIMENSION UNITS <b>mm</b>	SCALE <b>3:1</b>	CURRENT REV DESC: DRAWING UPDATED WITH NEW VIEW IN SHEET 4 TO ILLUSTRATE THE PANEL MOUNTING WITH SHOULDER SCREW AND NUT IN SHEET 4									
GENERAL TOLERANCES (UNLESS SPECIFIED)		<b>molex</b> 2CKT 6MM PANEL MOUNT RECEPTACLE HOUSING POWERWIZE PRODUCT FAMILY PRODUCT CUSTOMER DRAWING									
ANGULAR TOL	± 0.5°										
4 PLACES	±										
3 PLACES	±										
2 PLACES	± 0.15										
1 PLACE	± 0.25	EC NO: 745616	DRWN: CHETAB		2023/03/15		DOCUMENT NUMBER		DOC TYPE	DOC PART	REVISION
0 PLACES	±	DRWN: MBELLE	2020/03/30		2021/11/05		<b>2155116121</b>		PSD	000	<b>A3</b>
DRAFT WHERE APPLICABLE MUST REMAIN WITHIN DIMENSIONS		THIRD ANGLE PROJECTION	DRAWING	SERIES	MATERIAL NUMBER	CUSTOMER	SHEET NUMBER				
			<b>D-SIZE</b>	<b>215511</b>	2155116121	GENERAL MARKET	<b>4 OF 4</b>				