

- 1
- 2
- 3
- 4
- 5
- 6
- 7
- 8
- 9
- 10
- 11
- 12
- 13
- 14
- 15
- 16
- 17
- 18

**WHEEL BODY**

Phenolic based (PF) Duroplast monolithic wheel, resistant to temperatures up to 300°C.

**ROLLING ACTION**

Hub with steel and PTFE bosses.

**TURNING PLATE BRACKET**

Zinc-plated steel sheet, the bracket is designed to withstand loads up to 2000N. The presence of a double ball race and direct contact between the plate and the ball race ring with built-in pin ensure excellent manoeuvrability. Does not require maintenance. It consists of (see Fig.1):

1. fitting plate: electrolytically zinc-plated steel plate;
2. fork: electrolytically zinc-plated steel plate;
3. ball race ring: electrolytically zinc-plated steel plate;
4. central pin: incorporated in the plate, cold reflanged;
5. rotation system: dual ball ring, high temperature grease-lubricated;
6. dust seal: RAL 7015 dark grey technopolymer.

**STANDARD EXECUTIONS**

- **SBL**: turning plate bracket, without brake.
- **FBL**: turning plate bracket and centre pass-through hole, without brake.

**APPLICATIONS**

Being resistant to high temperatures, RE.F7-N-HT castor is particularly suitable for use in food industries and cooking ovens, especially in the baking sector.

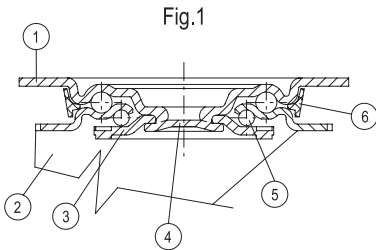



RE.F7-SBL-N

RE.F7-FBL-N

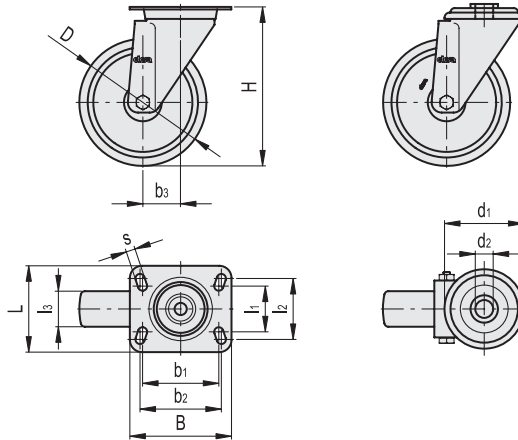

Conversion Table	
1 mm = 0.039 inch	
D	
mm	inch
80	3.15
100	3.94

RE.F7-SBL-N-HT

METRIC

Code	Description	D	l1	l2	l3	H	B	L	s	b1	b2	b3	Rolling resistance# [N]	Dynamic carrying capacity# [N]	⚖️
448556	RE.F7-080-SBL-N-HT	80	45	60	35	107	100	85	9	75	80	37	1250	1500	710
448561	RE.F7-100-SBL-N-HT	100	45	60	35	128	100	85	9	75	80	35	1300	2000	850

RE.F7-FBL-N-HT

Code	Description	D	d1	d2	l3	H	b3	Rolling resistance# [N]	Dynamic carrying capacity# [N]	⚖️
448683	RE.F7-080-FBL-N-HT	80	73	12	35	107	37	1250	1500	620
448685	RE.F7-100-FBL-N-HT	100	73	12	35	128	35	1300	2000	720

# For rolling resistance and dynamic carrying capacity see Technical data (on page 1296).