

This circuit is proprietary to Linear Technology and supplied for use with Linear Technology parts.

**Customer Notice:** Linear Technology has made a best effort to design a circuit that meets customer-supplied specifications; however, it remains the customer's responsibility to verify proper and reliable operation in the actual application. Component substitution and printed circuit board layout may significantly affect circuit performance or reliability. Contact Linear Applications Engineering for assistance.

REVISION HISTORY				
ECO	REV	DESCRIPTION	DATE	APPROVED
	2	PROTO	07/21/08	

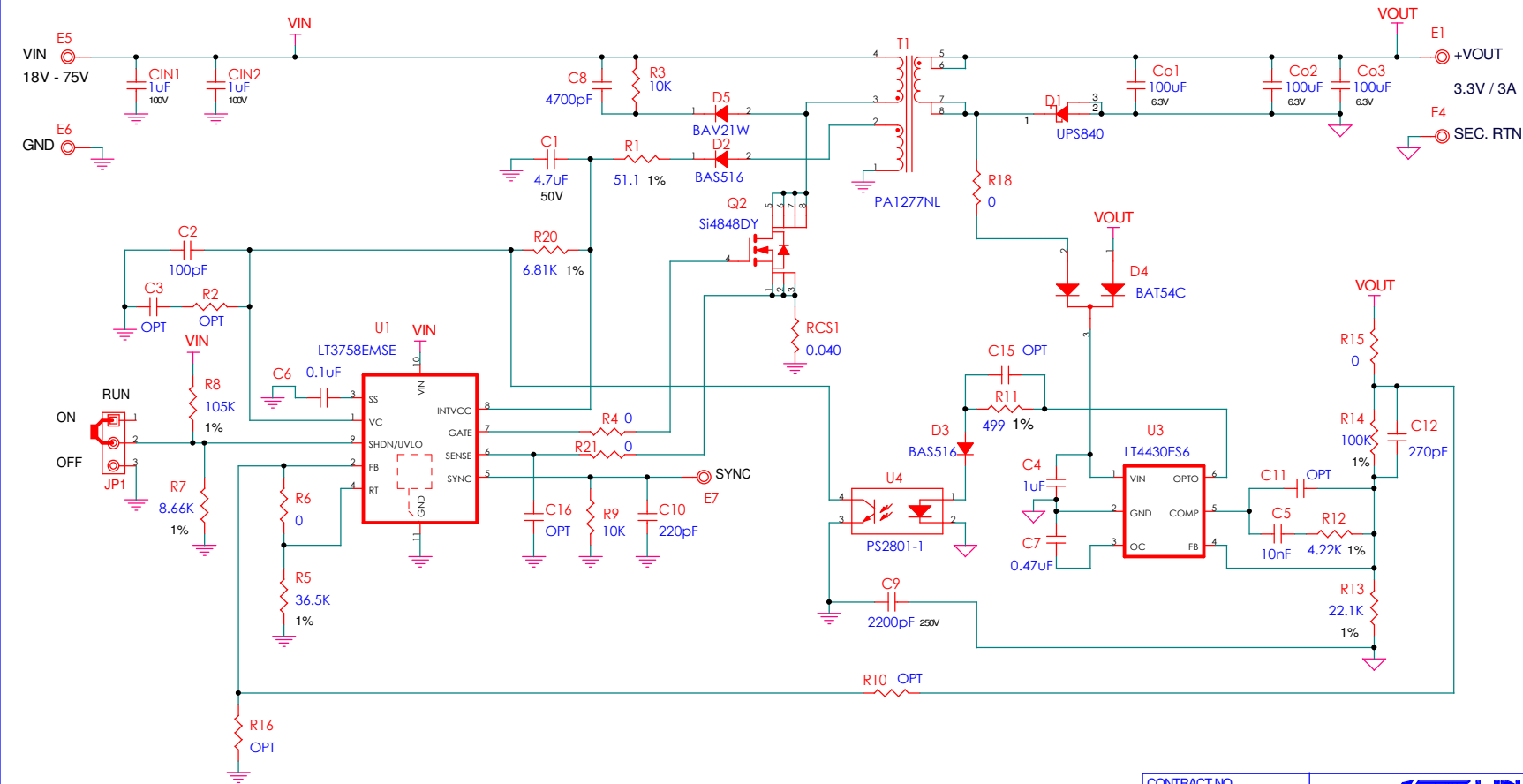

CONTRACT NO.		 <b>LINEAR</b> TECHNOLOGY	1630 McCarthy Blvd. Milpitas, CA 95035 Phone: (408)432-1900 Fax: (408)434-0507	
APPROVALS	DATE		TITLE	
DRAWN MI	03/14/07	SCH, LT3758EMSE, FLYBACK CONVERTER		
CHECKED		SIZE	CAGE CODE	DWG NO
APPROVED				REV 2
ENGINEER		DC1412A		
DESIGNER		SCALE: NONE	FILENAME: 1412A-2.DSN	SHEET 1 OF 1
Monday, May 04, 2009				