



### SPECIFICATIONS

Model	Max Torque	Reverse Torque	Damping Direction
FYN-LA3-R	10 Nm (100kgfcm)	10~60 Nm/(rad/sec)	Clockwise

Max Angle	Operating Temperature	Weight	Body and Cap Material	Rotating Shaft Material	Oil Type
210°	0 ~ 50°C	1.75kg	Zinc die-cast (ZDC)	Alloy steel	Silicone oil

### DAMPING CHARACTERISTICS

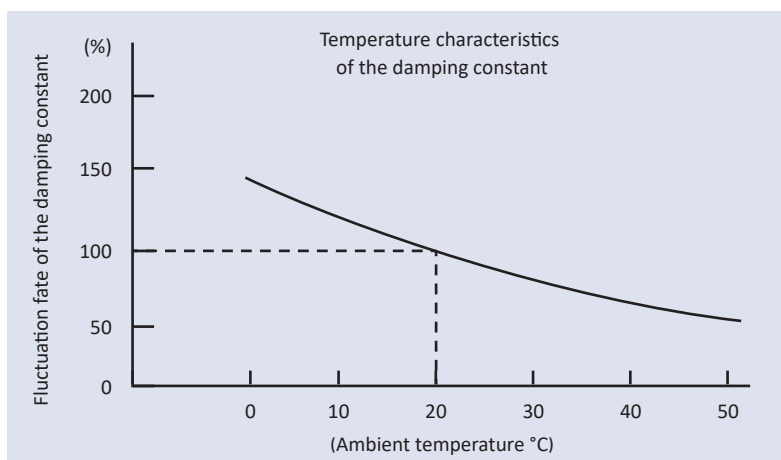

■ Damper characteristics vary according to the ambient temperature. In general, the damper characteristics become weaker as the temperature increases, and become stronger as the temperature decreases. This is because the viscosity of the oil inside the damper varies according to the temperature. When the temperature returns to normal, the damper characteristics will return to normal as well. The changes in the time it takes for the lid to close are shown in the graph to the left.

### HOW TO USE THE DAMPER

■ When using a damper on a lid, such as the one shown in the diagram, use the following selection calculation to determine the damper torque.

Example)

Lid mass M : 20kg

Lid dimensions L : 0.4m

Gravity Center Position :

Assumed as  $\frac{L}{2}$

Load torque :

$$T = 20 \times 9.8 \times 0.4 \div 2 = 39.2 \text{ N}\cdot\text{m}$$

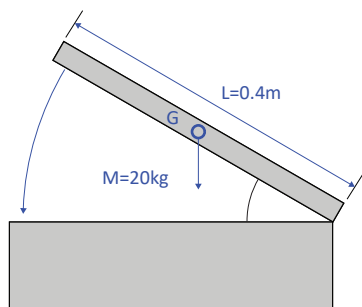

■ FYT, FYN-LA3 series are torque-adjustable types.

Turn the damping adjustment screw located on the back of the main body by inserting a slotted screwdriver.

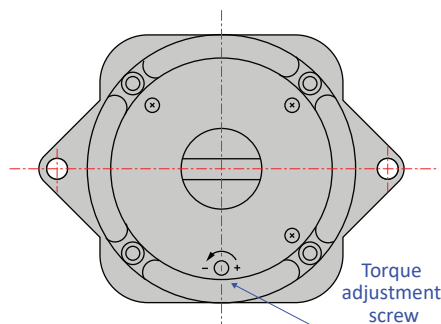

The damping constant increases when turned to the + direction (right).  
The damping constant decreases when turned to the - direction (left).

## INSTRUCTION FOR DAMPER ATTACHMENT

■ When attaching a rotating shaft to its corresponding part, ensure that they are firmly attached together by making the gap between them as small as possible. A large gap may affect the damper's non-damping range, preventing the lid from slowing down properly.

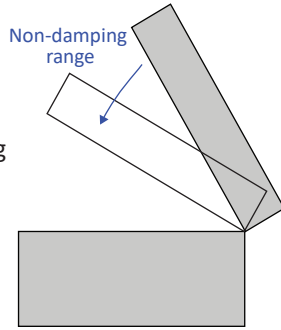

■ The damper's working angle is  $\pm 105^\circ$ , as shown on the right (second diagram). Please determine where to attach it according to your needs.

■ The direction in which torque is generated varies according to the model. Please select the appropriate model for your purpose.

■ Do not use the damper as a stopper. An external stopper must be attached at the stopping position.

■ In FYN-LA3-L and FYN-LA3-R, the angular velocity in the reverse direction (opposite to the direction of torque generation) should be 1 rad/sec or less.

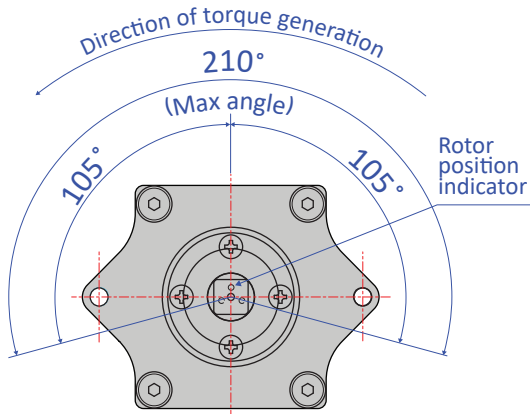

FYN-LA3-L

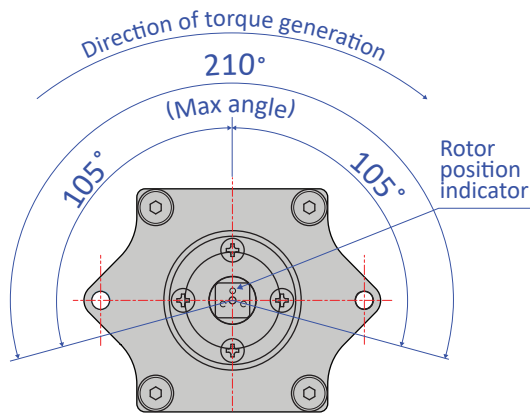

FYN-LA3-R

## HOW TO CALCULATE DAMPING CONSTANT

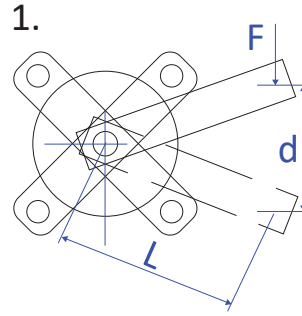

Delayed absorption in linear motion

### 1. Delayed absorption in linear motion

$$\text{Formula (N} \cdot \text{m}/(\text{rad}/\text{sec})) = \frac{FL^2t}{d}$$

F = Force or mass applied to the lever tip (N)

L = Distance between the centre of the damper shaft and the lever's point of application (m)

d = Distance travelled by lever (m)

t = Travelling time of the lever (sec)

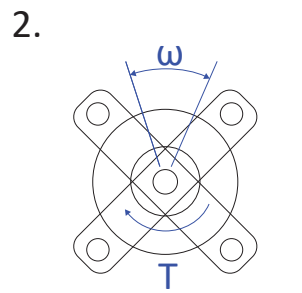

Delayed absorption in linear rotation

### 2. Delayed absorption in rotation

$$\text{Formula (N} \cdot \text{m}/(\text{rad}/\text{sec})) = \frac{T}{\omega}$$

T = Torque applied to shaft (N·m)

$\omega$  = Angular velocity(rad/sec)

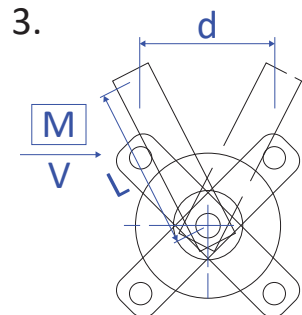

Impact absorption in linear motion

### 3. Impact absorption in linear motion

$$\text{Formula (N} \cdot \text{m}/(\text{rad}/\text{sec})) = \frac{MVL^2}{d}$$

M = Mass(kg)

V = Velocity(m/sec)

L = Distance between the centre of the damper shaft and the lever's point of application (m)

d = Distance travelled by lever (m)