

PART NUMBER	REVISION	DESCRIPTION	FEED TYPE
2151968-1	C	FINE CRIMP HEIGHT ADJUST	MECHANICAL
2151968-2	D	FINE CRIMP HEIGHT ADJUST	PNEUMATIC
7-2151968-1	C	MECHANICAL AND CRIMP TOOLING KIT	MECHANICAL
7-2151968-2	D	PNEUMATIC AND CRIMP TOOLING KIT	PNEUMATIC
7-2151968-7	A	CRIMP TOOLING KIT	-

ATLANTIC VERSION TERMINATOR INTERFACE ADAPTER



APPLICATOR DATA		
CRIMP	SIZE	TYPE
WIRE	1.60 mm [.063]	F
INSUL	2.00 mm [.079]	F

APPLICATOR INSTRUCTIONS
408-35042

TERMINAL DATA: MOLEX TERMINAL MOLEX CRIMP SPECIFICATION			
TERMINAL NAME: MINI FIT JR OVERALL TIN CRIMP TERMINAL			
WIRE STRIP LENGTH	INSULATION DIAMETER RANGE		
3.00-3.50 mm [.118-.138 IN]	∅ 1.40-1.70 mm [.055-.067 IN]		
TERMINAL APPLICATION SPECIFICATION MOLEX 63902-3900 Rev B			
TERMINALS APPLIED			
TE TERMINAL	MOLEX TERMINAL	TE TERMINAL	MOLEX TERMINAL
286603-1	39-00-0038	286611-1	39-00-0040
286603-2	39-00-0055	286611-2	39-00-0061
286603-3	39-00-0207	286611-3	39-00-0053
286603-4	39-00-0163	286611-4	39-00-0120
286603-5	39-00-0059	286611-5	39-00-0126
286603-6	39-00-0153	286611-6	39-00-0219
286603-7	39-00-0181	286611-9	39-00-0430
286603-8	39-00-0213	1-286611-1	39-00-0121
1-286603-1	39-00-0114	1-286611-2	39-00-0420
1-286603-2	39-00-0428	1-286611-3	39-00-0437
1-286603-3	39-00-0419	1-286611-4	39-00-0426
1-286603-4	39-00-0425	1-286611-6	39-00-0075
1-286603-5	39-00-0436	1-286611-7	39-00-0427
1-286603-6	39-00-0440	1-286611-8	40-13-0853
1-286603-7	39-00-0073	2-286611-0	30490-1002
1-286603-8	39-00-0108	2-286611-1	30490-2002
1-286603-9	39-00-0169	2-286611-2	40-01-0853
2-286603-0	39-00-0175	2-286611-3	98-00-0174
2-286603-1	39-00-0194	2-286611-4	30490-0002
2-286603-2	39-00-0200		
2-286603-3	39-00-0405		
2-286603-4	39-00-0407		
2-286603-5	39-00-0410		
2-286603-6	40-13-0851		
2-286603-7	44485-1211		
2-286603-8	44485-1311		
2-286603-9	44485-1411		

TERMINAL DATA: MOLEX TERMINAL MOLEX CRIMP SPECIFICATION			
TERMINAL NAME: MINI FIT JR OVERALL TIN CRIMP TERMINAL			
WIRE STRIP LENGTH	INSULATION DIAMETER RANGE		
3.00-3.50 mm [.118-.138 IN]	∅ 1.40-1.70 mm [.055-.067 IN]		
TERMINAL APPLICATION SPECIFICATION MOLEX 63902-3900 Rev B			
TERMINALS APPLIED			
TE TERMINAL	MOLEX TERMINAL	TE TERMINAL	MOLEX TERMINAL
2113022-1	45750-1211	1-2113022-2	46083-1221
2113022-2	45750-1111	1-2113022-3	46134-1111
2113022-3	46012-1111	1-2113022-4	46134-1121
2113022-4	46018-1541	1-2113022-5	46134-1211
2113022-5	46083-1111	1-2113022-6	46134-1221
2113022-6	46098-1541	1-2113022-7	46012-1261
2113022-7	46012-1141	286603-9	44476-1111
2113022-8	46012-1211	2-286603-7	44476-1211
2113022-9	46012-1241	286611-7	44478-1111
1-2113022-0	46083-1121	1-286611-9	44478-1211
1-2113022-1	46083-1211		

WIRE SIZE	CRIMP HEIGHT mm [INCH]	CRIMP HEIGHT REFERENCE SETTING
0.8 or 18	1.020+/-0.050 [.0400+/-0.0020]	7.1
0.5 or 20	0.995+/-0.045 [.0390+/-0.0020]	7.1

WIRE SIZE	CRIMP HEIGHT mm [INCH]	CRIMP HEIGHT REFERENCE SETTING
0.8 or 18	1.020+/-0.050 [.0400+/-0.0020]	7.1
0.5 or 20	0.995+/-0.045 [.0390+/-0.0020]	7.1
0.35 or 22	0.895+/-0.045 [.0350+/-0.0020]	8.6
0.2 or 24	0.830+/-0.040 [.0325+/-0.0015]	9.2

- 1. RECOMMENDED SPARE PARTS
- 2. REFER TO SUPPLIED INSTRUCTION SHEET FOR CLEANING, LUBRICATION AND STORAGE OF APPLICATOR.
- 3. APPLY PART NUMBER 2-23419-6 LOCTITE TO THREADS OF ITEM 242.
- 4. CRIMP HEIGHT REFERENCE SETTING WAS THE SETTING USED WHEN THE APPLICATOR WAS QUALIFIED AT THE FACTORY. ADJUSTMENT MAY BE NECESSARY WHEN RUNNING APPLICATOR IN THE FIELD.
- 5. UNLESS SPECIFIED OTHERWISE TORQUE VALUES SHALL BE USED PER DOCUMENT, 101-35000.

***WARNING**
ON INSTALLATION, SET WIRE DISC TO CRIMP HEIGHT REFERENCE SETTING FOR LARGEST WIRE SIZE. CRIMP HEIGHT REFERENCE SETTINGS GREATER THAN THE VALUE SHOWN MAY CAUSE DAMAGE TO THE CRIMP TOOLING, REFER TO THE INSTRUCTION SHEET FOR PROPER SETUP AND ADJUSTMENTS.

ATLANTIC VERSION
Shown on sheets 1 of 4 & 2 of 4
(Pacific version shown on sheets 3 of 4 & 4 of 4)

LOC	DIST	REVISIONS					
A	66	P	LTN	DESCRIPTION	DATE	DWN	APVD
		B1		ECR-16-000025	04JAN2016	JH	CT
		C		ECR-18-006802	04MAY2018	KH	JDG
		D		ECR-20-013302	18SEP2020	FJ	TE
		D1		ECR-22-147998	01AUG2022	FJ	YY

-	1	-	1	-	2119641-1	FEED CAM, AIR FEED	248
-	1	1	1	1	2119082-3	CAM, SNAIL, INSULATION ADJUSTMENT	244
-	1	1	1	1	2079764-1	WASHER, WAVE SPRING, CREST-TO-CREST	243
-	1	1	1	1	2119083-1	RETAINER, INSULATION DIAL	242
-	1	1	1	1	7-18023-7	SCR, SKT HD CAP M3 X 4.0	241
-	-	1	-	1	2119580-1	MECHANICAL FEED ASSEMBLY	239
-	1	-	1	-	2844940-1	AIR FEED MODULE	238
-	REF	REF	REF	REF	994970-2	COUNTER, MAGNETIC	164
-	1	1	1	1	2844908-1	SCREW, LOCKING	99
-	1	1	1	1	2844907-1	POST, LOCKING	98
-	1	1	1	1	455888-4	SPACER, CRIMPER	82
-	1	1	1	1	5-547505-2	SPRING, COMPRESSION	77
-	1	1	1	1	854769-4	HOLDER, INS	74
-	1	1	1	1	1803607-3	DOCUMENTATION PACKAGE	71
-	1	1	1	1	2119740-1	TAG, IDENTIFICATION	67
-	2	2	2	2	2168078-1	SCREW, DRIVE, RH, RoHS, 2 x .188	66
-	1	1	1	1	2168083-2	SCR, SKT HD CAP, RoHS, M4 X 8.0	60
-	1	1	1	1	5-18022-5	SCR, HEX HD CAP, M4 X 6.0	59
-	1	1	1	1	21028-2	PIN, SLOTTED SPRING .062 X .250	58
-	1	1	1	1	1338685-1	PAWL, FEED	56
-	4	4	4	4	2168083-3	SCR, SKT HD CAP, RoHS, M4 X 12.0	54
-	2	2	2	2	2-2168083-5	SCR, SKT HD CAP, RoHS, M4 X 14	53
-	1	1	1	1	5018030-1	NUT, HEX, REG, RoHS, M3	52
-	1	1	1	1	811242-5	BUMPER, HOLD DOWN	51
-	1	1	1	1	690753-2	SPACER, TONKER	50
-	1	2	1	2	18023-9	SCR, SKT HD CAP M4 X 6.0	49
-	-	1	-	1	2119652-1	FEED CAM, PRE FEED	48
-	-	1	-	1	2119653-1	FEED CAM, POST FEED	47
-	1	1	1	1	1803583-9	APPLICATOR BASIC ASSEMBLY, SF	46
-	1	1	1	1	1803515-1	RAM ASSEMBLY, SF ATLANTIC	44
-	1	1	1	1	1803602-1	SCR, BHSC, RoHS (M8 X 25)	41
-	1	1	1	1	1752356-9	SUPPORT, TERMINAL	34
-	2	2	2	2	2079383-5	SCR, BHSC, RoHS (M4 X 20)	33
-	2	2	2	2	2-2844962-4	SPACER, CYLINDRICAL, STRIP GUIDE	30
-	1	1	1	1	2844992-1	ASSEMBLY, STRIP GUIDE	29
-	1	1	1	1	455888-3	SPACER, CRIMPER	28
-	1	1	1	1	1320928-2	STRIP GUIDE	24
-	1	1	1	1	2168083-2	SCR, SKT HD CAP, RoHS, M4 X 8.0	21
-	2	2	2	2	1-18028-2	WASHER, FLAT, REG M4	20
-	1	1	1	1	2119533-1	STRIPPER, SIDE FEED	19
-	1	1	1	1	2119806-1	INSERT, SHEAR	13
-	1	1	1	1	3-22280-3	SPRING, COMPRESSION	12
-	1	1	1	1	1-356885-4	STOP, SHEAR	11
-	1	1	1	1	2119805-1	SHEAR HOLDER, FRONT	10
-	1	1	1	1	1803095-1	FLOATING SHEAR, FRONT	9
-	1	2	2	1	1803056-1	ANVIL, COMBINATION	8
-	1	1	1	1	3-240641-0	SPACER	7
-	-	-	-	-	-	-	6
-	1	1	1	1	1-2119780-1	DEPRESSOR, SHEAR	5
-	1	1	1	1	238011-7	BLOCK, CRIMPER SPACER	4
-	1	2	2	1	3-1633962-6	CRIMPER, INSULATION F PREMIUM	3
-	1	1	1	1	455888-4	SPACER, CRIMPER	2
-	1	2	2	1	2-1633738-0	CRIMPER, WIRE	1

DIMENSIONS:		TOLERANCES UNLESS OTHERWISE SPECIFIED:		MATERIAL:		FINISH:		WEIGHT:		SCALE:		SHEET:		REV:	
mm	0 PLC ±	1 PLC ±	2 PLC ±	3 PLC ±	4 PLC ±	ANGLES	FINISH			A1	00779	2151968	1	4	D1

LOC	DIST	REVISIONS					
		P	LTN	DESCRIPTION	DATE	OWN	APVD
A	66	-	-	SEE SHEET 1	-	-	-

FEED TYPE MECHANICAL

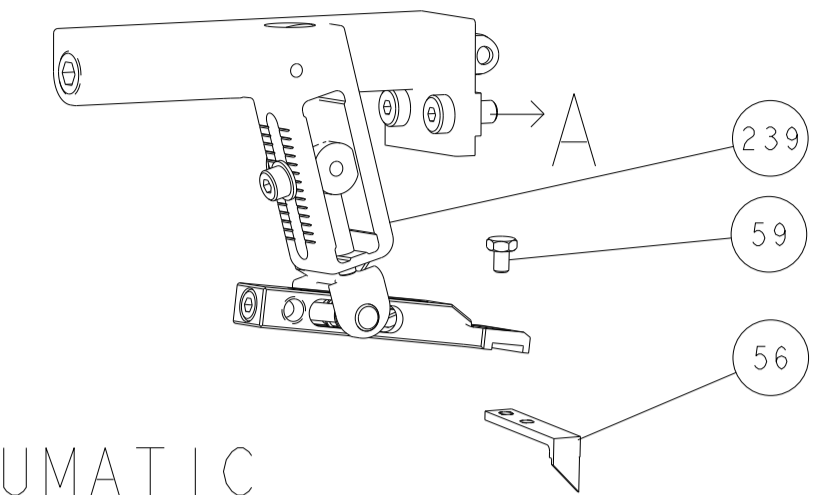

PNEUMATIC

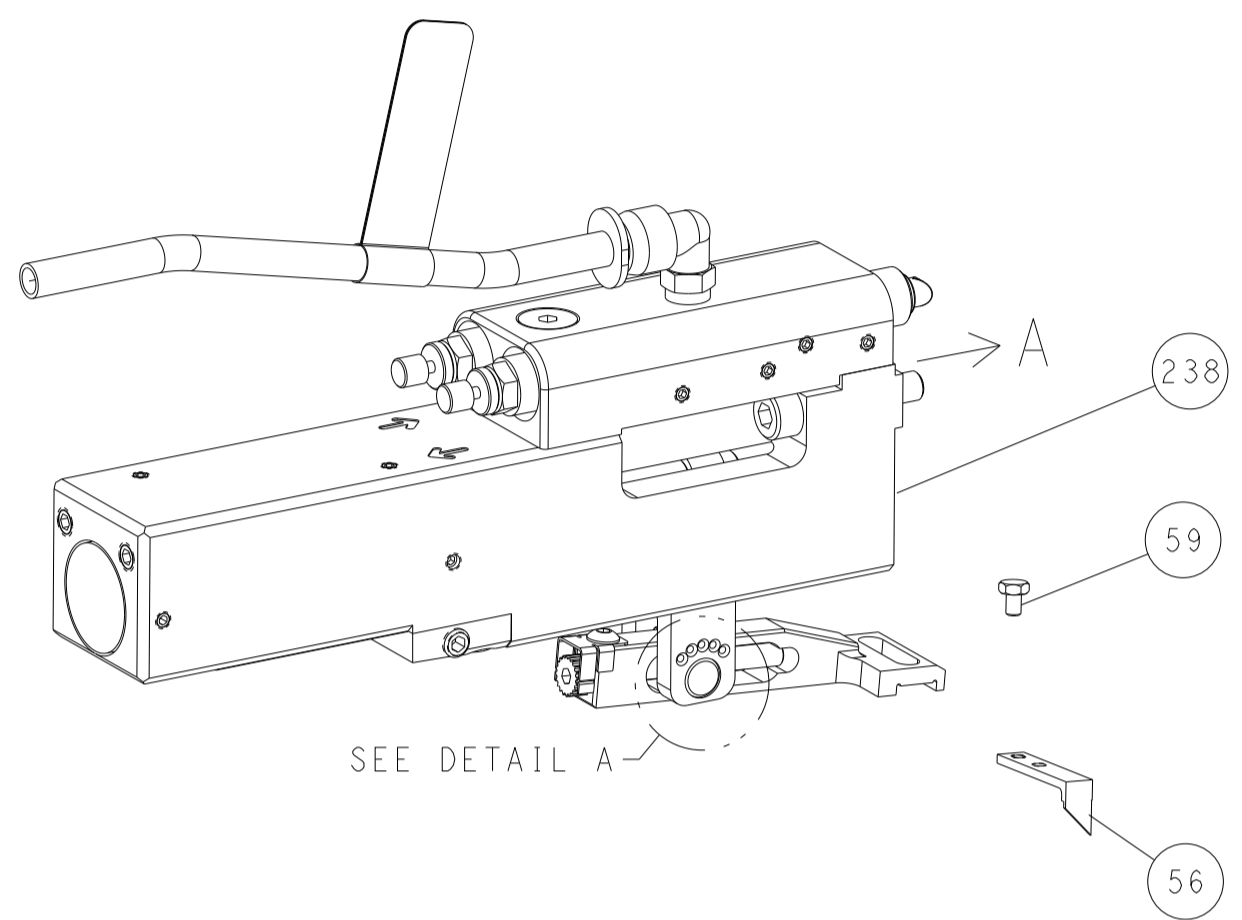

FEED SPRING SETTING POSITION (SHOWN FROM REAR SIDE)



DETAIL A

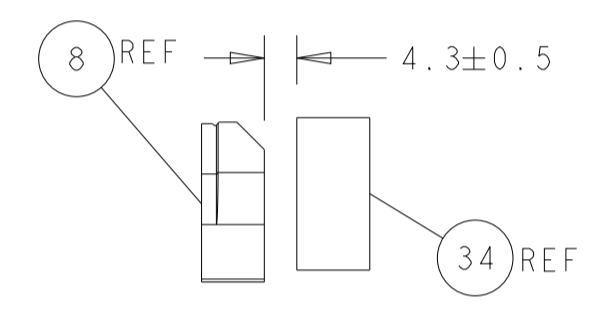
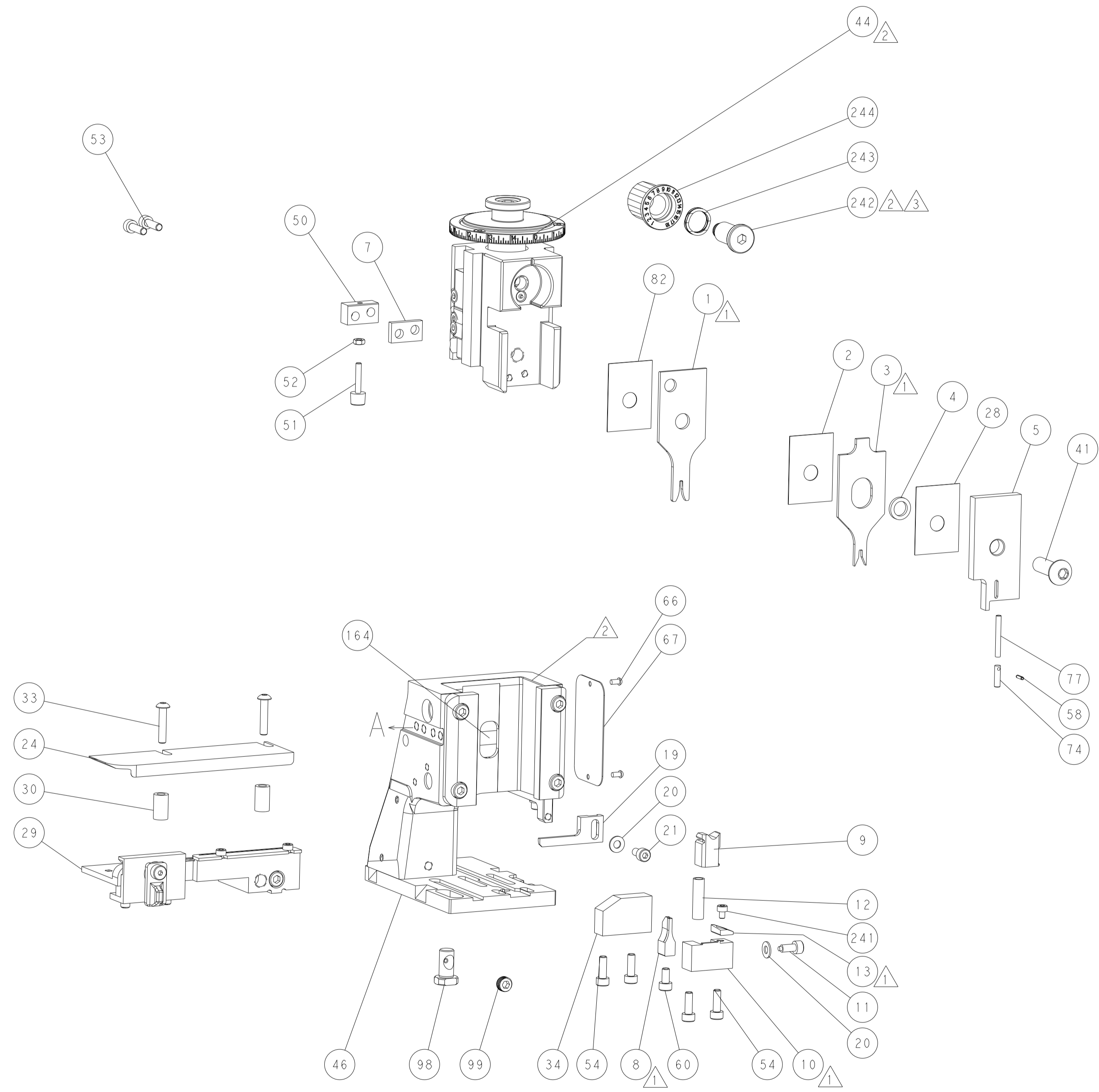

TERMINAL SUPPORT LOCATION

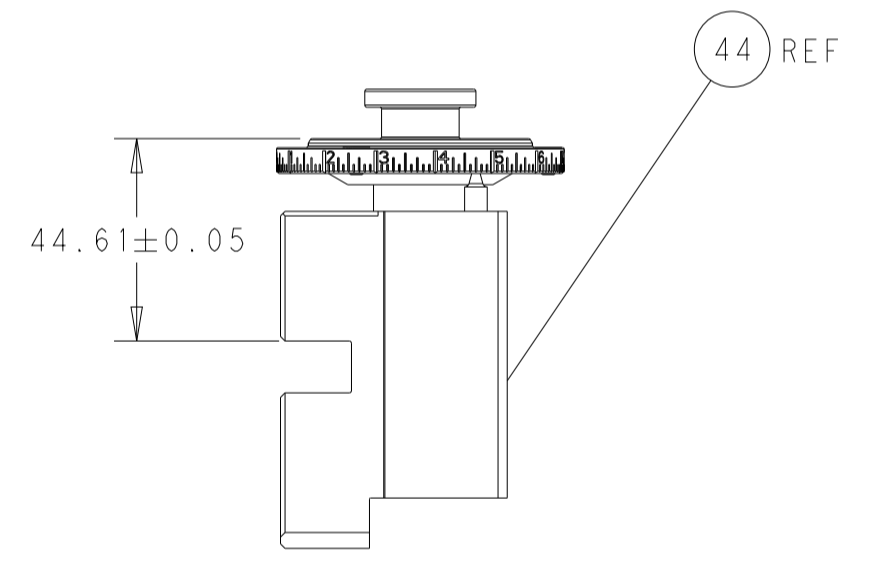

RAM SET-UP

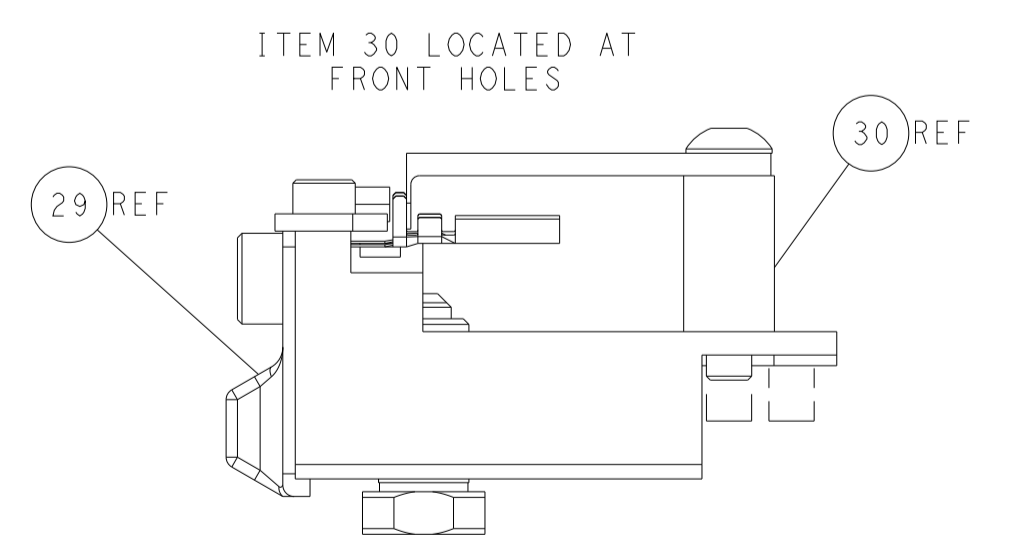

FEED TRACK POSITION GUIDE BY INSULATION BARREL

CAM POSITIONS

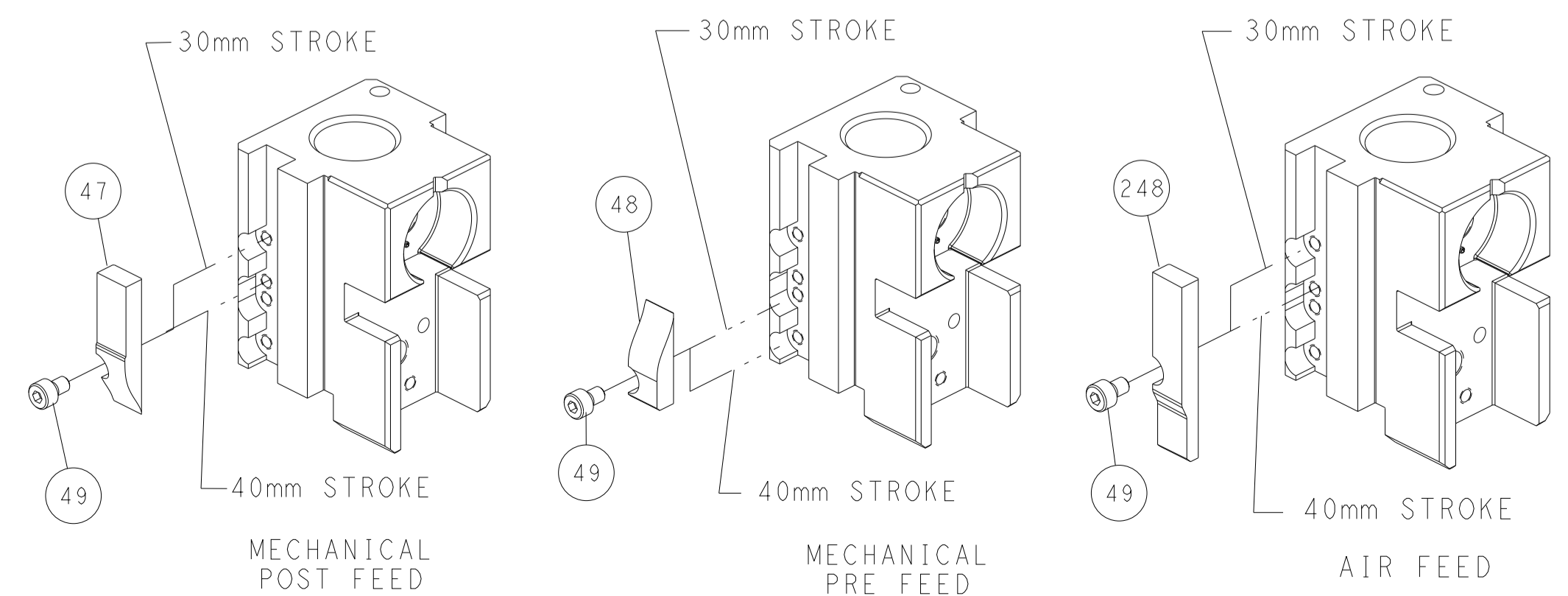

ATLANTIC VERSION
 Shown on sheets 1 of 4 & 2 of 4
 (Pacific version shown on sheets 3 of 4 & 4 of 4)

<small>THIS DRAWING IS UNPUBLISHED. RELEASED FOR PUBLICATION BY TYCO ELECTRONICS CORPORATION. ALL RIGHTS RESERVED.</small>		DWN BOB HIGMAN 28MAY2013 CHK G. BAILEY 28MAY2013 APVD M. CLIFFORD 28MAY2013	NAME Ocean Side Feed Applicator
DIMENSIONS: mm 	TOLERANCES UNLESS OTHERWISE SPECIFIED: 0 PLC ± 1 PLC ± 2 PLC ± 3 PLC ± 4 PLC ± ANGLES FINISH ±	PRODUCT SPEC APPLICATION SPEC WEIGHT	SIZE CAGE CODE DRAWING NO A1 00779 ©=2151968
MATERIAL:		RESTRICTED TO:	SCALE 1:2 SHEET 2 OF 4 REV D1

PART NUMBER	REVISION	DESCRIPTION	FEED TYPE
2-2151968-1	C	FINE CRIMP HEIGHT ADJUST	MECHANICAL
2-2151968-2	D	FINE CRIMP HEIGHT ADJUST	PNEUMATIC
7-2151968-7	A	CRIMP TOOLING KIT	-

PACIFIC VERSION TERMINATOR
 INTERFACE ADAPTER

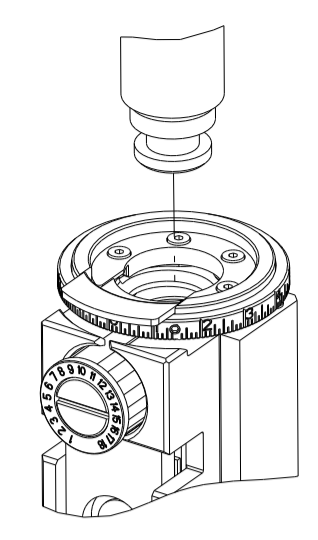

APPLICATOR DATA

CRIMP	SIZE	TYPE
WIRE	1.60 mm [.063]	F
INSUL	2.00 mm [.079]	F

APPLICATOR INSTRUCTIONS
 408-35042

TERMINAL DATA: MOLEX TERMINAL MOLEX CRIMP SPECIFICATION

TERMINAL NAME: MINI FIT JR OVERALL TIN CRIMP TERMINAL

WIRE STRIP LENGTH	INSULATION DIAMETER RANGE
3.00-3.50 mm [.118-.138 IN]	Ø 1.40-1.70 mm [.055-.067 IN]

TERMINAL APPLICATION SPECIFICATION MOLEX 63902-3900 Rev B

TERMINALS APPLIED

TE TERMINAL	MOLEX TERMINAL	TE TERMINAL	MOLEX TERMINAL
286603-1	39-00-0038	286611-1	39-00-0040
286603-2	39-00-0055	286611-2	39-00-0061
286603-3	39-00-0207	286611-3	39-00-0053
286603-4	39-00-0163	286611-4	39-00-0120
286603-5	39-00-0059	286611-5	39-00-0126
286603-6	39-00-0153	286611-6	39-00-0219
286603-7	39-00-0181	286611-9	39-00-0430
286603-8	39-00-0213	1-286611-1	39-00-0121
1-286603-1	39-00-0114	1-286611-2	39-00-0420
1-286603-2	39-00-0428	1-286611-3	39-00-0437
1-286603-3	39-00-0419	1-286611-4	39-00-0426
1-286603-4	39-00-0425	1-286611-6	39-00-0075
1-286603-5	39-00-0436	1-286611-7	39-00-0427
1-286603-6	39-00-0440	1-286611-8	40-13-0853
1-286603-7	39-00-0073	2-286611-0	30490-1002
1-286603-8	39-00-0108	2-286611-1	30490-2002
1-286603-9	39-00-0169	2-286611-2	40-01-0853
2-286603-0	39-00-0175	2-286611-3	98-00-0174
2-286603-1	39-00-0194	2-286611-4	30490-0002
2-286603-2	39-00-0200		
2-286603-3	39-00-0405		
2-286603-4	39-00-0407		
2-286603-5	39-00-0410		
2-286603-6	40-13-0851		
2-286603-7	44485-1211		
2-286603-8	44485-1311		
2-286603-9	44485-1411		

WIRE SIZE	CRIMP HEIGHT mm [INCH]	CRIMP HEIGHT REFERENCE SETTING
0.8 or 18	1.020+/-0.050 [.0400+/-0.0020]	7.1
0.5 or 20	0.995+/-0.045 [.0390+/-0.0020]	7.1
0.35 or 22	0.895+/-0.045 [.0350+/-0.0020]	8.6
0.2 or 24	0.830+/-0.040 [.0325+/-0.0015]	9.2

- RECOMMENDED SPARE PARTS
- REFER TO SUPPLIED INSTRUCTION SHEET FOR CLEANING, LUBRICATION AND STORAGE OF APPLICATOR.
- APPLY PART NUMBER 2-23419-6 LOCTITE TO THREADS OF ITEM 242.
- CRIMP HEIGHT REFERENCE SETTING WAS THE SETTING USED WHEN THE APPLICATOR WAS QUALIFIED AT THE FACTORY. ADJUSTMENT MAY BE NECESSARY WHEN RUNNING APPLICATOR IN THE FIELD.
- 5. UNLESS SPECIFIED OTHERWISE TORQUE VALUES SHALL BE USED PER DOCUMENT, 101-35000.

TERMINAL DATA: MOLEX TERMINAL MOLEX CRIMP SPECIFICATION

TERMINAL NAME: MINI FIT JR OVERALL TIN CRIMP TERMINAL

WIRE STRIP LENGTH	INSULATION DIAMETER RANGE
3.00-3.50 mm [.118-.138 IN]	Ø 1.40-1.70 mm [.055-.067 IN]

TERMINAL APPLICATION SPECIFICATION MOLEX 63902-3900 Rev B

TERMINALS APPLIED

TE TERMINAL	MOLEX TERMINAL	TE TERMINAL	MOLEX TERMINAL
2113022-1	45750-1211	1-2113022-2	46083-1221
2113022-2	45750-1111	1-2113022-3	46134-1111
2113022-3	46012-1111	1-2113022-4	46134-1121
2113022-4	46018-1541	1-2113022-5	46134-1211
2113022-5	46083-1111	1-2113022-6	46134-1221
2113022-6	46098-1541	1-2113022-7	46012-1261
2113022-7	46012-1141	286603-9	44476-1111
2113022-8	46012-1211	2-286603-7	44476-1211
2113022-9	46012-1241	286611-7	44478-1111
1-2113022-0	46083-1121	1-286611-9	44478-1211
1-2113022-1	46083-1211		

WIRE SIZE	CRIMP HEIGHT mm [INCH]	CRIMP HEIGHT REFERENCE SETTING
0.8 or 18	1.020+/-0.050 [.0400+/-0.0020]	7.1
0.5 or 20	0.995+/-0.045 [.0390+/-0.0020]	7.1

***WARNING**
 ON INSTALLATION, SET WIRE DISC TO CRIMP HEIGHT REFERENCE SETTING FOR LARGEST WIRE SIZE. CRIMP HEIGHT REFERENCE SETTINGS GREATER THAN THE VALUE SHOWN MAY CAUSE DAMAGE TO THE CRIMP TOOLING, REFER TO THE INSTRUCTION SHEET FOR PROPER SETUP AND ADJUSTMENTS.

PACIFIC VERSION
 Shown on sheets 3 of 4 & 4 of 4
 (Atlantic version shown on sheets 1 of 4 & 2 of 4)

LOC: A DIST: 66

REV	DATE	DESCRIPTION	DATE	OWN	APVD
-	-	SEE SHEET 1	-	-	-

-	1	1	2119082-3	CAM, SNAIL, INSULATION ADJUSTMENT	244
-	1	1	2079764-1	WASHER, WAVE SPRING, CREST-TO-CREST	243
-	1	1	2119083-1	RETAINER, INSULATION DIAL	242
-	1	1	7-18023-7	SCR, SKT HD CAP M3 X 4.0	241
-	-	1	2119580-1	MECHANICAL FEED ASSEMBLY	239
-	1	-	2844940-1	AIR FEED MODULE	238
-	REF	REF	994970-2	COUNTER, MAGNETIC	164
-	1	-	2119641-2	FEED CAM, AIR FEED	151
-	1	1	2168083-8	SCR, SKT HD CAP, RoHS, M4 X 16	144
-	4	4	2168083-9	SCR, SKT HD CAP, RoHS, M4 X 20	143
-	-	1	2119653-2	FEED CAM, POST FEED	142
-	1	1	1-1803583-0	APPLICATOR BASIC ASSEMBLY, SF	141
-	1	1	1803516-1	RAM ASSEMBLY, SF PACIFIC	140
-	1	1	2844908-1	SCREW, LOCKING	99
-	1	1	2844907-1	POST, LOCKING	98
-	1	1	455888-4	SPACER, CRIMPER	82
-	1	1	5-547505-2	SPRING, COMPRESSION	77
-	1	1	854769-4	HOLDER, INS	74
-	1	1	1803607-3	DOCUMENTATION PACKAGE	71
-	1	1	2119740-1	TAG, IDENTIFICATION	67
-	2	2	2168078-1	SCREW, DRIVE, RH, RoHS, 2 x .188	66
-	1	1	5-18022-5	SCR, HEX HD CAP, M4 X 6.0	59
-	1	1	21028-2	PIN, SLOTTED SPRING .062 X .250	58
-	1	1	1338685-1	PAWL, FEED	56
-	2	2	2-2168083-5	SCR, SKT HD CAP, RoHS, M4 X 14	53
-	1	1	5018030-1	NUT, HEX, REG, RoHS, M3	52
-	1	1	811242-5	BUMPER, HOLD DOWN	51
-	1	1	690753-2	SPACER, TONKER	50
-	1	2	18023-9	SCR, SKT HD CAP M4 X 6.0	49
-	-	1	2119652-1	FEED CAM, PRE FEED	48
-	1	1	1803602-1	SCR, BHSC, RoHS (M8 X 25)	41
-	1	1	1752356-9	SUPPORT, TERMINAL	34
-	2	2	2079383-5	SCR, BHSC, RoHS (M4 X 20)	33
-	2	2	2-2844962-4	SPACER, CYLINDRICAL, STRIP GUIDE	30
-	1	1	2844992-1	ASSEMBLY, STRIP GUIDE	29
-	1	1	455888-3	SPACER, CRIMPER	28
-	1	1	1320928-2	STRIP GUIDE	24
-	1	1	2168083-2	SCR, SKT HD CAP, RoHS, M4 X 8.0	21
-	2	2	1-18028-2	WASHER, FLAT, REG M4	20
-	1	1	2119533-1	STRIPPER, SIDE FEED	19
-	1	1	2119806-1	INSERT, SHEAR	13
-	1	1	3-22280-3	SPRING, COMPRESSION	12
-	1	1	1-356885-4	STOP, SHEAR	11
-	1	1	2119805-1	SHEAR HOLDER, FRONT	10
-	1	1	1803095-1	FLOATING SHEAR, FRONT	9
-	1	1	1803056-1	ANVIL, COMBINATION	8
-	1	1	3-240641-0	SPACER	7
-	-	-	-	-	6
-	1	1	1-2119780-1	DEPRESSOR, SHEAR	5
-	1	1	238011-7	BLOCK, CRIMPER SPACER	4
-	1	1	3-1633962-6	CRIMPER, INSULATION F PREMIUM	3
-	1	1	455888-4	SPACER, CRIMPER	2
-	1	1	2-1633738-0	CRIMPER, WIRE	1
-	77	22	21	PART NO	ITEM NO

DIMENSIONS:	TOLERANCES UNLESS OTHERWISE SPECIFIED:	APVD	DATE	DESCRIPTION	REV
mm	0 PLC ±.015 1 PLC ±.010 2 PLC ±.008 3 PLC ±.006 4 PLC ±.005 ANGLES ±.010	BOB HIGMAN G. BAILEY M. CLIFFORD	28MAY2013 28MAY2013 28MAY2013	TE Connectivity Harrisburg, PA 17105-3608	1
MATERIAL:		WEIGHT:		Customer Accessible Production Drawing	
SCALE: 1:2		SHEET: 3 OF 4		REV: D1	

LOC	DIST	REVISIONS					
A	66	P	LTN	DESCRIPTION	DATE	DWN	APVD
		-		SEE SHEET 1			

FEED TYPE MECHANICAL

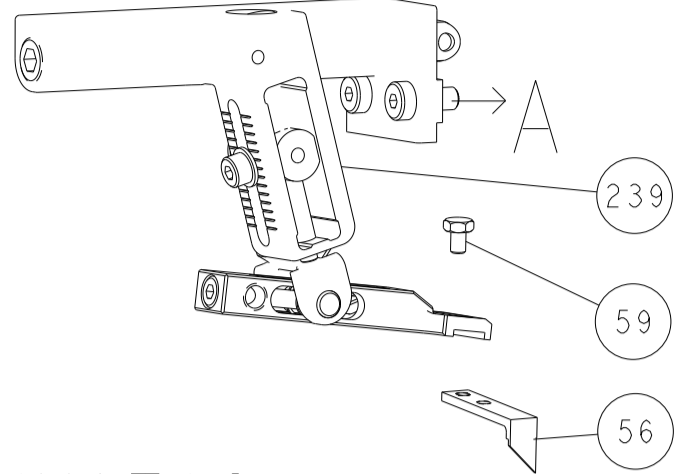

PNEUMATIC

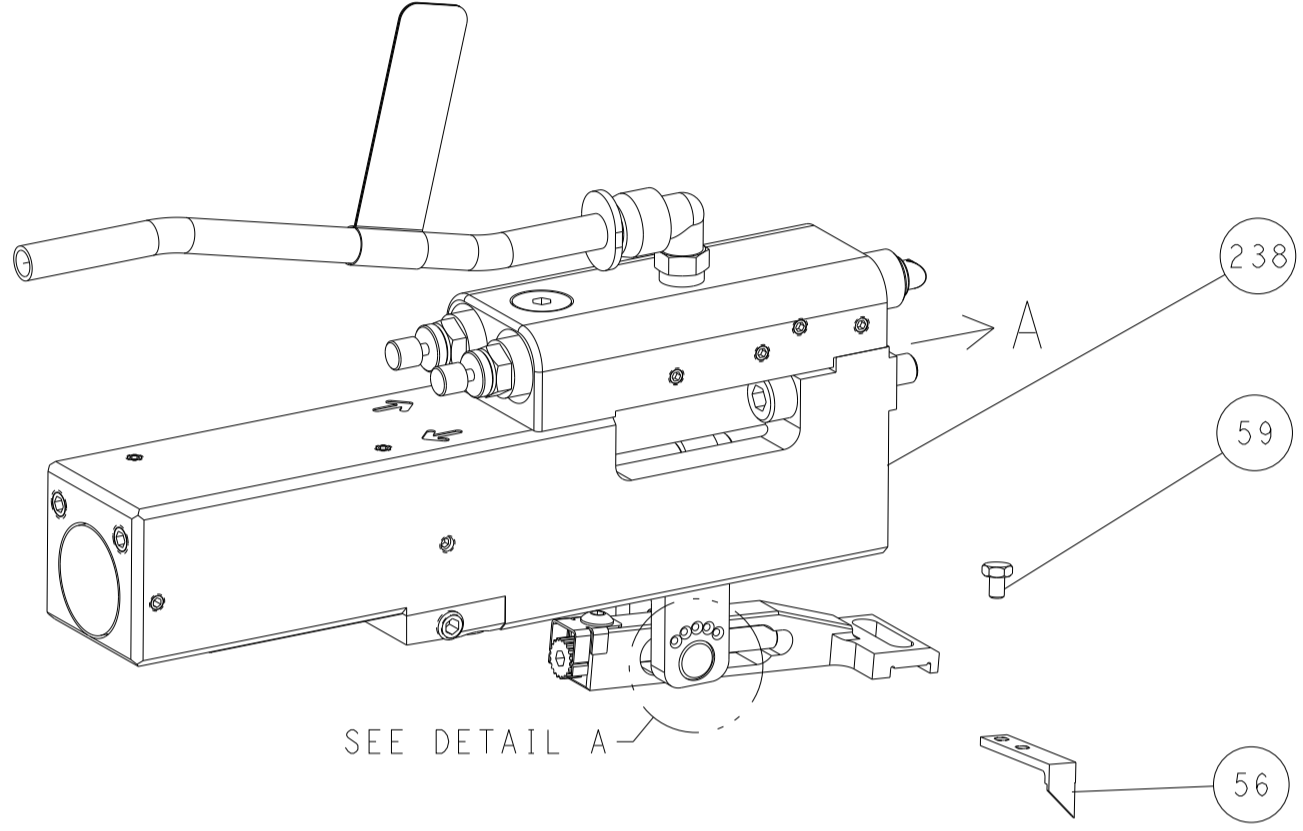

FEED SPRING SETTING POSITION (SHOWN FROM REAR SIDE)



CAM POSITIONS

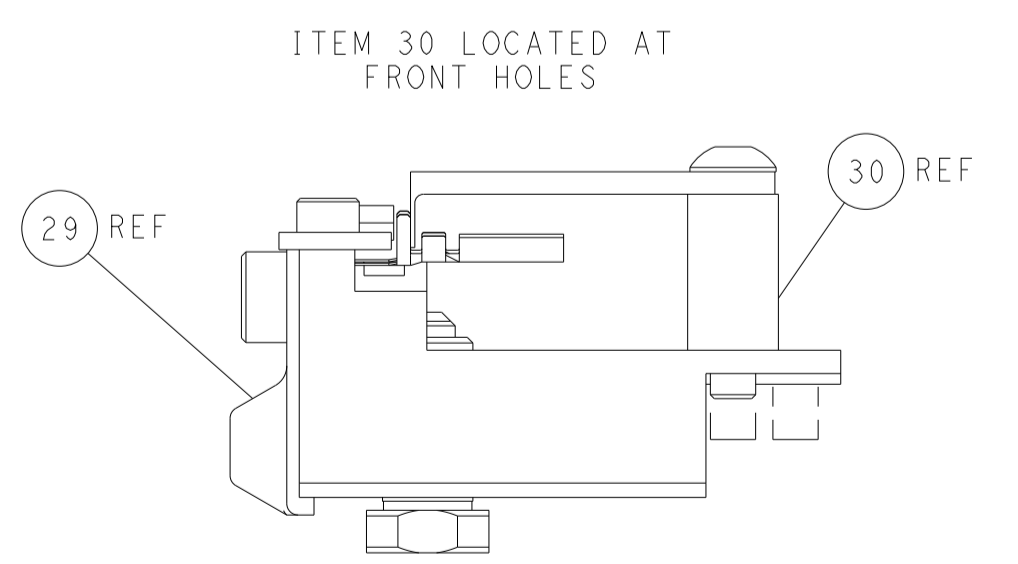
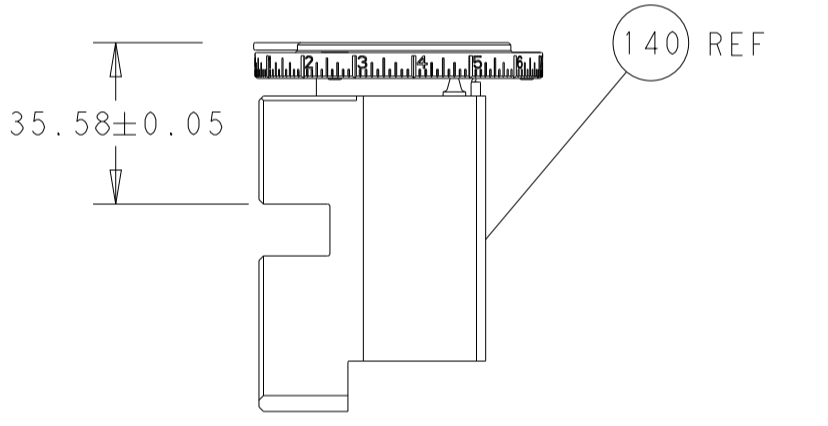
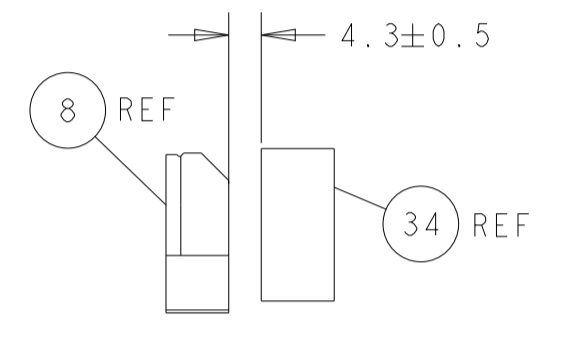
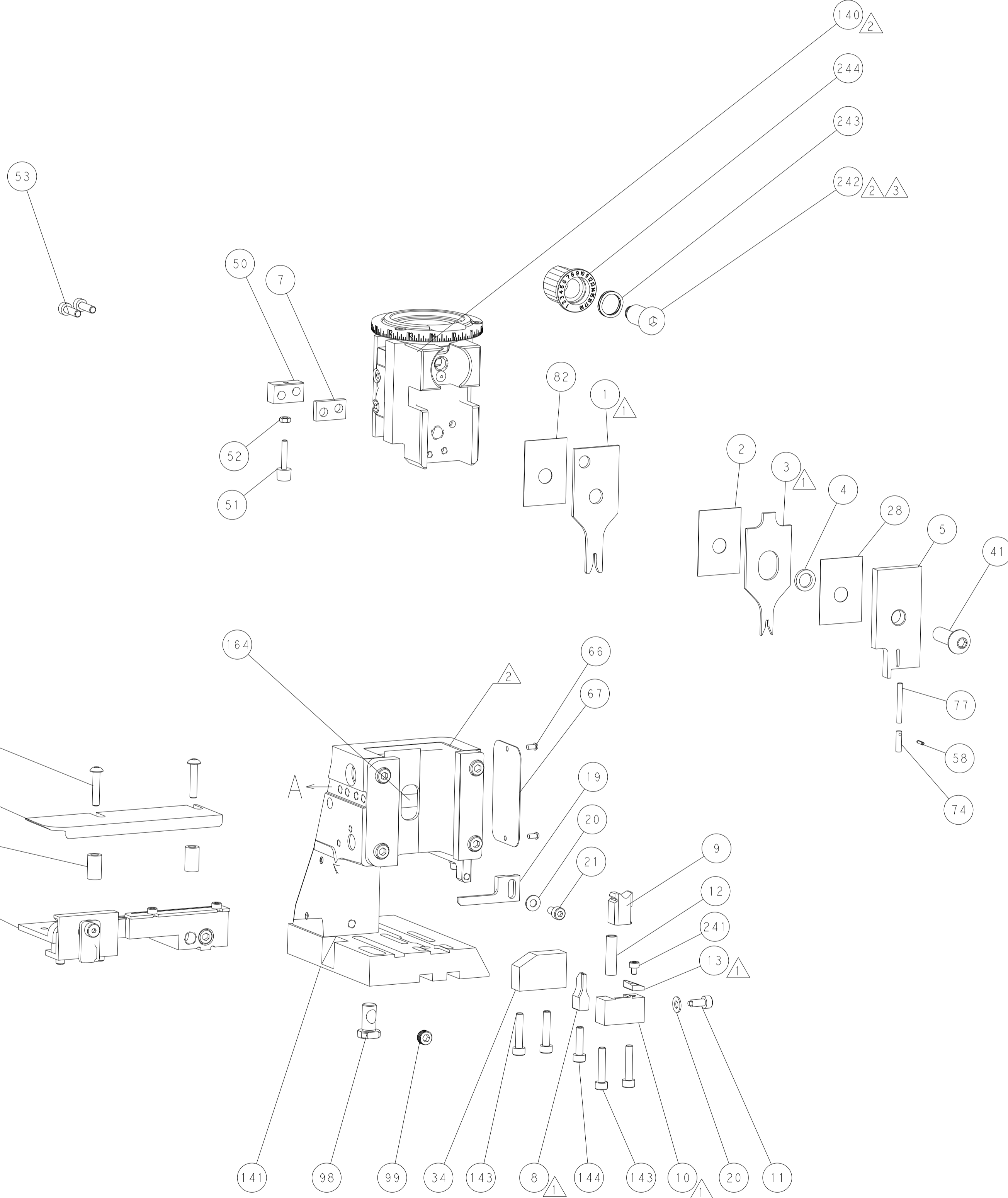
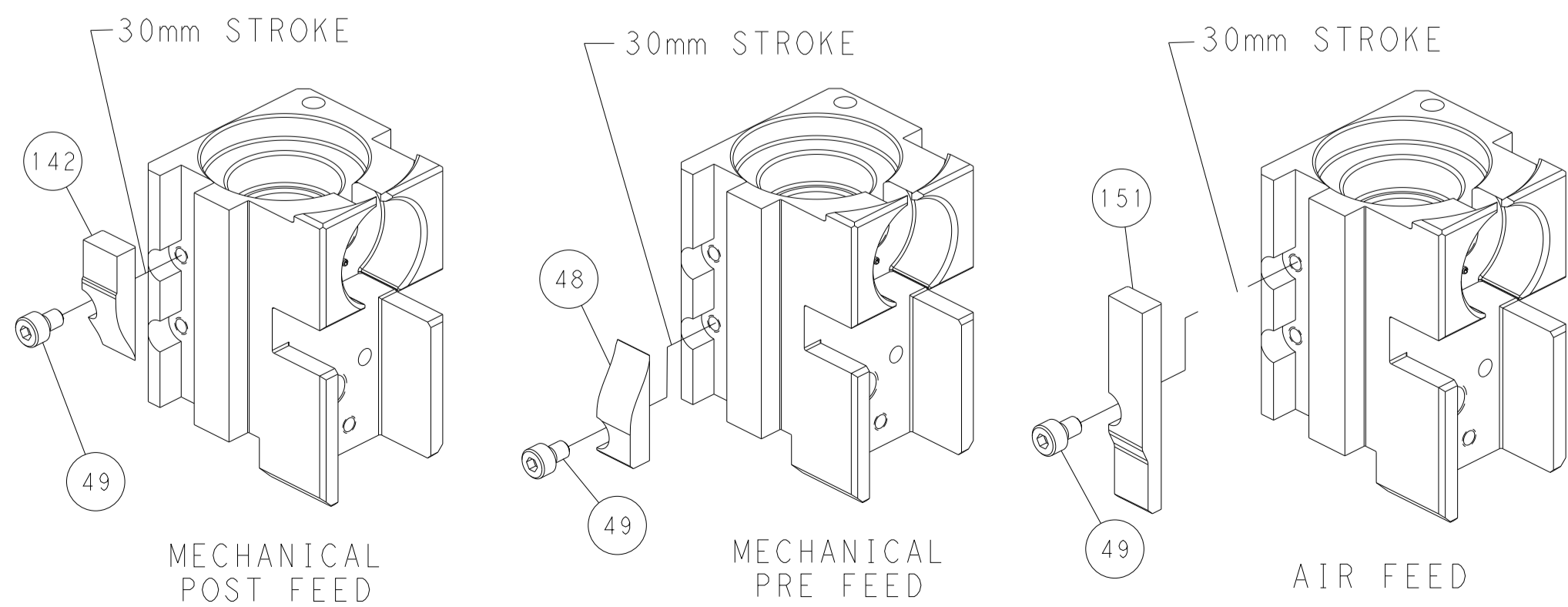

FEED TRACK POSITION GUIDE BY INSULATION BARREL

PACIFIC VERSION
 Shown on sheets 3 of 4 & 4 of 4
 (Atlantic version shown on sheets 1 of 4 & 2 of 4)

<small>THIS DRAWING IS A CONTROLLED DOCUMENT FOR TYCO ELECTRONICS CORPORATION. IT IS THE PROPERTY OF COMPANY AND IS NOT TO BE REPRODUCED OR TRANSMITTED IN ANY FORM OR BY ANY MEANS, ELECTRONIC OR MECHANICAL, WITHOUT THE WRITTEN PERMISSION OF TYCO ELECTRONICS CORPORATION.</small>		DWN: BOB HIGMAN 28MAY2013 CHK: G. BAILEY 28MAY2013 APVD: M. CLIFFORD 28MAY2013	TE Connectivity Harrisburg, PA 17105-3608
DIMENSIONS: mm TOLERANCES UNLESS OTHERWISE SPECIFIED: 0 PLC ± 1 PLC ± 2 PLC ± 3 PLC ± 4 PLC ± ANGLES FINISH ±		NAME: Ocean Side Feed Applicator APPLICATION SPEC: - SIZE: A1 CAGE CODE: 00779 DRAWING NO: C-2151968	RESTRICTED TO: - SCALE: 1:2 SHEET: 4 of 4 REV: D1
MATERIAL: - FINISH: -		WEIGHT: - Customer Accessible Production Drawing	SHEETS 1 & 2 ARE NOT REQUIRED FOR PACIFIC VERSION