

REV	CHANGE	DATE	DRN	CHK
	Drawn	12/20/16	SJ	T

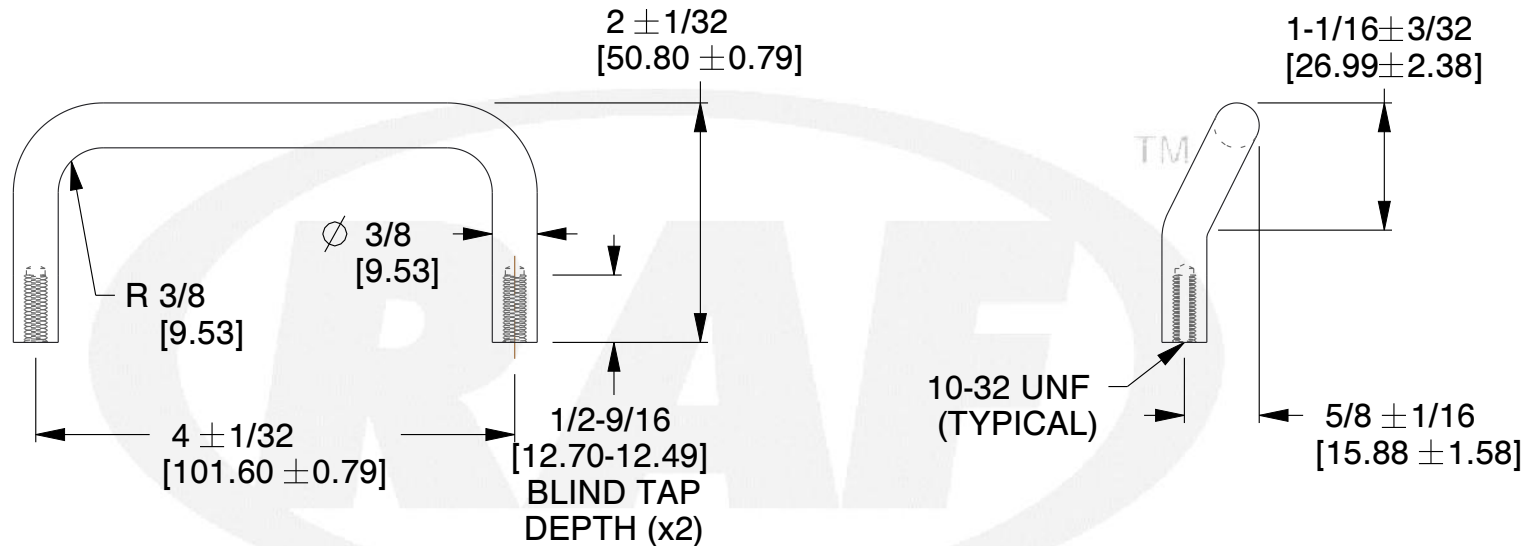

**NOTES:**

1. Material : Stainless Steel (ASTM-A-581, A-582) (RoHS Comp.)
2. Finish : Nickel QQ-N-290 Class 1 Grade G
3. % of Thread for Tapped Holes : Form Tap - 55 | Cut Tap - 65
- 4: Threads are Supplied Cut or Rolled at RAF's Option Unless Noted on Order.
5. Threads are to Commercial 2A and 2B Standards per Handbook H-28 (Part 1)
6. All Drawing Dimensions are in Inches Unless Noted Otherwise
7. ASME Y14.5M - 2009
8. Unless otherwise specified; Edge Breaks, Radii or Countersinks 0.005-0.015

COMPONENT	HANDLES
8310-1032-SS	SCALE
	0.62
	SHEET
INTERNAL THREAD HANDLE	1 of 1



95 Silvermine Rd., Seymour CT 06483  
Tel: 203-888-2133, Fax: 203-888-9860

This Drawing is the Property of RAF.  
It contains confidential, proprietary information that is RAF property. Do not disclose to or duplicate for others except as authorized by RAF.

**TOLERANCES**  
ALL DIMENSIONS ARE INCHES (UNLESS OTHERWISE SPECIFIED)  
**METALLIC**  
LENGTHS <math>\leq 6</math> INCHES  $\pm 0.005$   
LENGTH > 6 INCHES  $\pm 0.010$   
DIAMETERS:  $\pm 0.005$   
**NON-METALLIC**  
LENGTH:  $\pm 0.010$  DIAMETERS:  $\pm 0.010$   
**INTERNAL THREADS:**  
MINIMUM THREAD DEPTH