

RECOMMENDED  
CABLE STRIPPING DIMENSIONS  
SWITCHCRAFT STRIPPING TOOL #PTS1

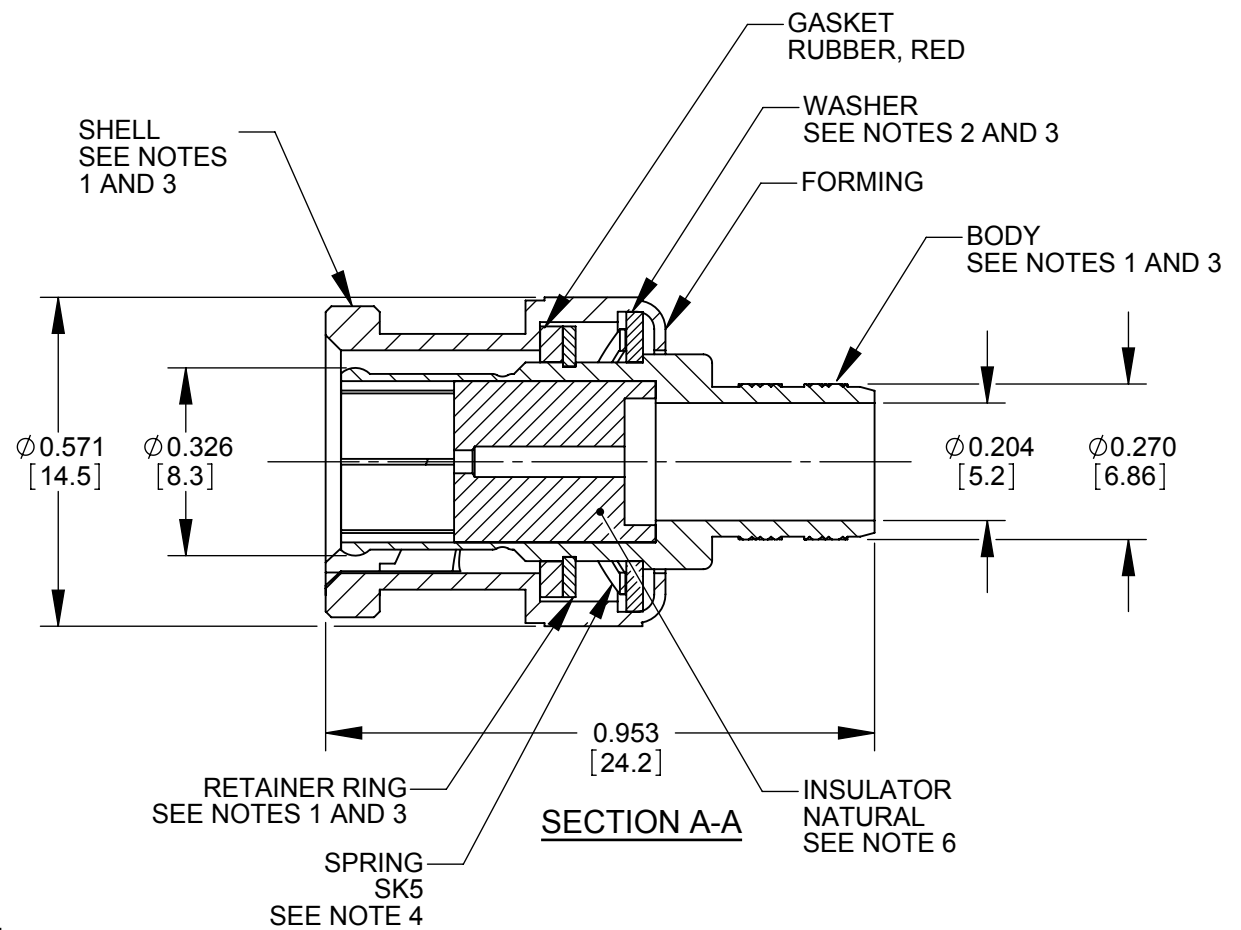
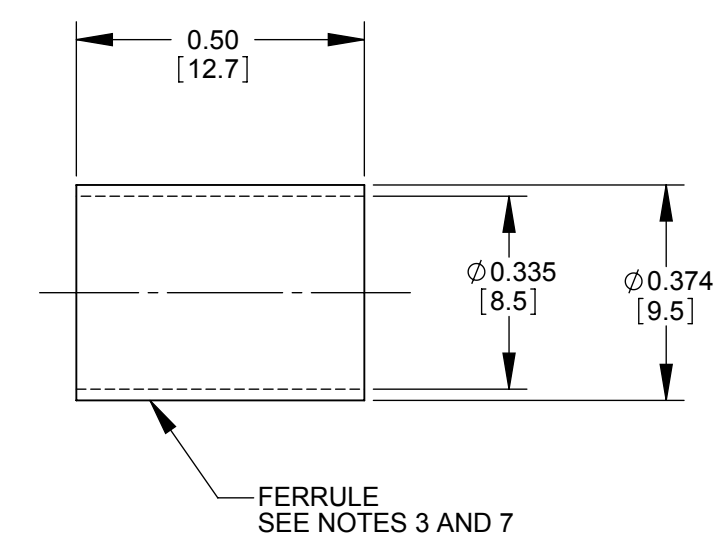
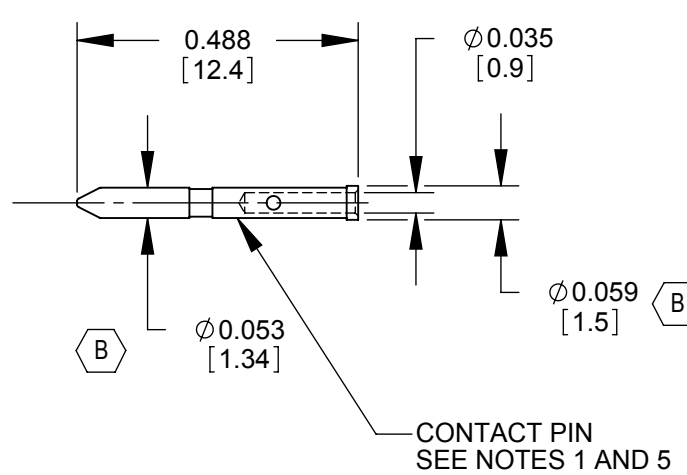

NOTES:

FINISH (PLATING THICKNESS IN MICRO-INCHES)

1. BRASS PER 00-8-626
2. BRASS PER 00-8-613
3. NICKEL PLATING 100 MIN THICK OVER COPPER STRIKE.
4. NICKEL PLATING 200 MIN THICK OVER COPPER STRIKE.
5. GOLD PLATING 3 MIN THICK OVER NICKEL PLATING 100 MIN THICK OVER COPPER STRIKE.
6. TEFLON MIL-P-19468
7. JIS H 3250, C 2700
8. CRIMPED FERRULE HEX CRIMP SIZE 0.324.
9. CRIMPED CONTACT PIN SQUARE CRIMP SIZE 0.042.
10. ALL DIMENSIONS ARE FOR REFERENCE ONLY.
11. THIS PRODUCT IS RoHS COMPLIANT.

**CUSTOMER DRAWING**

REV	ECO NUMBER	DATE	BY	APVD
B	26364	3-31-09	RS	TJK
A	26142	10-31-06	RF	TJK
REVISIONS				

☆ STAR SYMBOL DENOTES CRITICAL DIMENSION

UNLESS OTHERWISE SPECIFIED

1. ALL DIMENSIONS IN INCHES
  - TWO PLACE DECIMALS ±0.01
  - THREE PLACE DECIMALS ±0.005
  - ANGLES ±1°
  - ALL DIA. CONCENTRIC WITHIN 0.005 T.I.R.
2. FEATURES ON THE SAME CENTERLINE MUST BE ALIGNED WITHIN ±0.002
3. REMOVE ALL BURRS

**DO NOT SCALE DRAWING**

THIS DRAWING DESCRIBES A DESIGN CONSIDERED PROPRIETARY IN NATURE, DEVELOPED AND MANUFACTURED BY SWITCHCRAFT INC. AND IS RELEASED ON A CONFIDENTIAL BASIS FOR IDENTIFICATION PURPOSES ONLY.										
SIZE	WIDTH	MULT	LBS/M	TEMPER						
FINISH					MATERIAL					
SPEC No.					SPEC No.					
FIRST USED ON					SCALE					
					3:1					
DATE DRAWN	BY	CHKD	APVD							
10-31-06	RF	RF	TJK							
			10-31-06	10-31-06						
NAME 75 OHM BNC CONNECTOR 8281B CABLE, RoHS								PART No. HP75BNC2X		REV B