

DATE	REV	ECN	APP'D. BY
5-16-19	A0	-	-

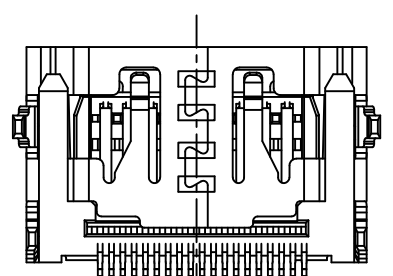
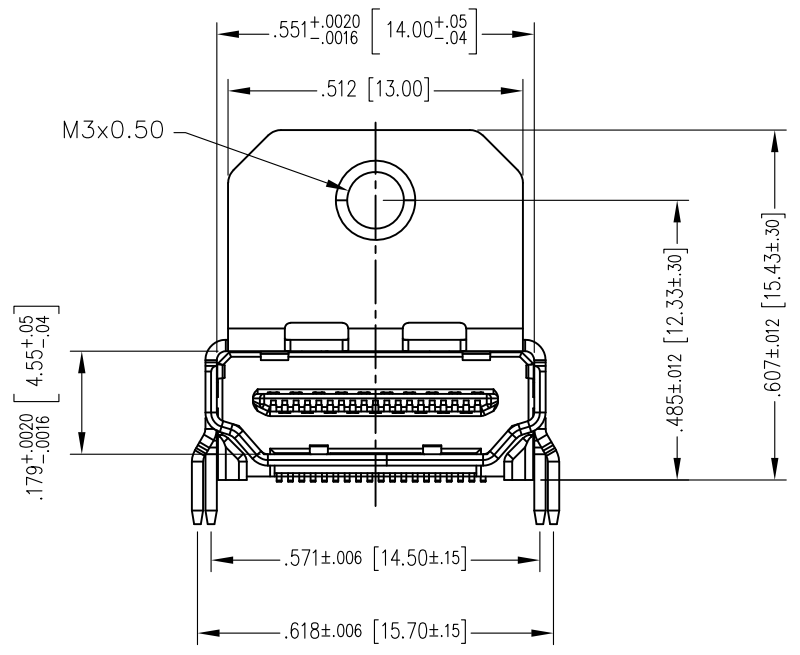
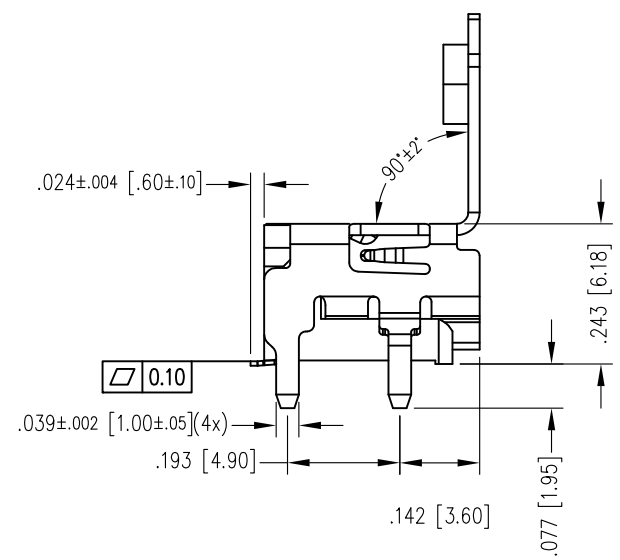
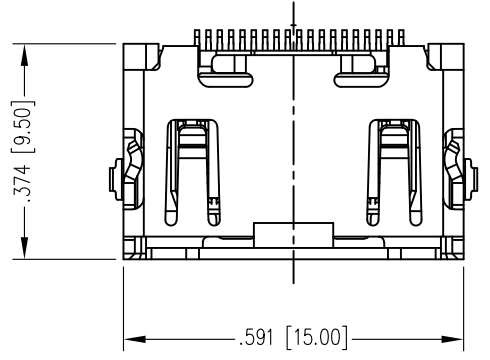
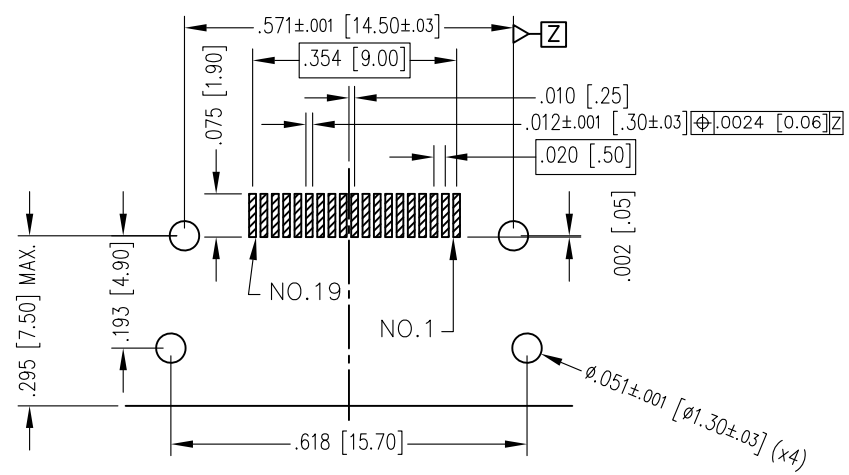

- NOTES:
- MATERIAL:
HOUSING AND BRACKET: HIGH TEMP.THERMOPLASTIC, UL 94V-0
COLOR: BLACK.
CONTACT: COPPER ALLOY, THICKNESS =0.20MM
SHIELD: SPCC, THICKNESS=0.50MM
 - FINISH:
CONTACT: 30u" GOLD PLATING ON CONTACT AREA
80u" MIN ,MATTE TIN PLATED ON SOLDER TAILS
50u" MIN. NICKEL UNDER PLATED OVER ALL
SHIELD: 50u" MIN. NICKEL PLATED OVER ALL
 - MECHANICAL CHARACTERISTICS
INSERTION FORCE: 44.1N MAX
EXTRACTION FORCE: 9.8N MIN, 39.2N MAX
MATING CYCLE: 10000 CYCLES
 - ELECTRICAL CHARACTERISTICS
CURRENT RATING: 0.5A
VOLTAGE RATING: 40V
CONTACT RESISTANCE: 10 MILLOHMS OHMS MAX
(EXCLUDING CONDUCTOR RESISTANCE)
INSULATION RESISTANCE:
a, UNMATED: 100M OHMS MIN AT 500 VDC
b, MATED: 10M OHMS MIN AT 150 VDC
DIELECTRIC WITHSTANDING VOLTAGE: 300V AC/1MINUTE
OPERATING TEMPERATURE: -20°C--+85°C
STORAGE TEMPERATURE: -20°C--+65°C
 - PACKAGING
100 PARTS PER TRAY
2000 PARTS PER CARTON
TRAY DIMENSIONS: 11.2x6.2x0.8 [285x158x20]

30 MICRO-INCHES [0.76um]	SS-53000-002
CONTACT PLATING IN MATING AREA	PART NUMBER

THIRD ANGLE PROJECTION 	 stewart CONNECTOR a bel group	1118 Susquehanna Trail South Glen Rock, PA 17327-9199 (717) 235-7512 http://www.stewartconnector.com
DO NOT SCALE DRAWING DRAWING IS SUBJECT TO CHANGE WITHOUT NOTICE	TITLE: HDMI JACK RIGHT ANGLE WITH FLANGE	
DIMENSIONS: INCHES [METRIC] UNLESS OTHERWISE SPECIFIED TOLERANCES ARE ±.008 [0.20] ANGLES ARE ± 1°	DRN BY: JMM DATE: 4-9-19	APPD BY: ADB DATE: 5-16-19
SHEET NO. 1 OF 1	DWG NO. CT530002 REV. A0	



B

B

A

A