

LOC AI	DIST 00	REVISIONS			
P	LTR	DESCRIPTION	DATE	DWN	APVD
	A2	ECR-19-000287	08JAN19	LS	GS

HTV10 HAND TOOL, Tandem Spring

FRONT VIEW



BACK VIEW



Eigenschaften / Features

Der Crimpkopf verfügt über drei Crimpnester in denen unterschiedliche Leitungsquerschnitte verarbeitet werden können. Die Kontakte werden über den Kontaktpositionierer in die richtige Ausgangsposition positioniert.

Crimping head featured with three crimping nests to enable processing of different wire sizes. Terminals will be correct inserted by Locator.

Crimp nester / Crimp nests

Anz. Pos.	cross-sectional area SQ.MM	AWG
1	0.03 - 0.09	32 - 28
2	0.2 - 0.56	24 - 20
3	0.12 - 0.14	26

Abmessungen / Dimension

Länge/Length: 193 mm

Breite/Width: 64 mm

Tiefe/Depth: 22 mm

Anwendungsbereich / Application range

cross-sectional area mm ²	Crimp Height mm	TERMINALS
0,03 - 0,09	0,53 +/-0,03	167042-1
0,2 - 0,56	0,77 +/-0,03	166722-1
0,12 - 0,14	0,72 +/-0,03	166722-1

Ersatzteile / Spare parts

TE P/N 4-539785-9 - FLAP LOCATOR
ASSEMBLY

Bedienungsanleitung / Operating instructions

411-18618 / TE PN 6-744017-4

RELEASED FOR PUBLICATION

ALL INTERNATIONAL RIGHTS RESERVED.

BY TYCO ELECTRONICS CORPORATION.

COPYRIGHT

THIS DRAWING IS UNPUBLISHED.

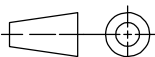
DIMENSIONS: mm		DWN C. Witt 21OCT2009	MATERIAL	FINISH
TOLERANCES UNLESS OTHERWISE SPECIFIED:		CHK G. Stegmayer 21OCT2009	 TE Connectivity	
0 PLC ± - 1 PLC ± - 2 PLC ± - 3 PLC ± - 4 PLC ± - ANGLES ± -		APVD G. Stegmayer 21OCT2009		
		PRODUCT SPEC	NAME HTV10 HAND TOOL, TANDEM SPRING HTV10 Handzange, Tandem Spring	
		APPLICATION SPEC	SIZE A4	CAGE CODE 00779
		WEIGHT 0.27kg	DRAWING NO C-169481-2	RESTRICTED TO -
		CUSTOMER DRAWING		SCALE _____ SHEET 1 OF 1 REV A2