

MAX-7 / NEO-7

u-blox 7 GNSS modules

Hardware Integration Manual

Abstract

This document describes the features and specifications of the cost effective and high-performance MAX-7 and NEO-7 GPS/GLONASS/QZSS modules featuring the u-blox 7 positioning engine.

These compact, easy to integrate stand-alone GNSS receiver modules combine exceptional GNSS performance with highly flexible power, design, and connectivity options. Their compact form factors and SMT pads allow fully automated assembly with standard pick & place and reflow soldering equipment for cost-efficient, high-volume production enabling short time-to-market.



Document Information

Title	MAX-7 / NEO-7	
Subtitle	u-blox 7 GNSS modules	
Document type	Hardware Integration Manual	
Document number	UBX-13003704	
Revision and date	R10	02-Jun-2021
Document status	Production Information	

Document status explanation

Objective Specification	Document contains target values. Revised and supplementary data will be published later.
Advance Information	Document contains data based on early testing. Revised and supplementary data will be published later.
Early Production Information	Document contains data from product verification. Revised and supplementary data may be published later.
Production Information	Document contains the final product specification.

European Union regulatory compliance

MAX-7 and NEO-7 complies with all relevant requirements for RED 2014/53/EU. The MAX-7 and NEO-7 Declaration of Conformity (DoC) is available at www.u-blox.com within Support > Product resources > Conformity Declaration.

This document applies to the following products:

Product name	Type number	ROM/FLASH version	PCN reference
MAX-7C-0	All	ROM1.00	N/A
MAX-7Q-0	All	ROM1.00	UBX-21015025
MAX-7W-0	All	ROM1.00	N/A
NEO-7N-0	All	FLASH1.00	N/A
NEO-7M-0	All	ROM1.00	N/A
NEO-7P-0	All	FLASH1.01	N/A

u-blox reserves all rights to this document and the information contained herein. Products, names, logos and designs described herein may in whole or in part be subject to intellectual property rights. Reproduction, use, modification or disclosure to third parties of this document or any part thereof without the express permission of u-blox is strictly prohibited.

The information contained herein is provided "as is" and u-blox assumes no liability for the use of the information. No warranty, either express or implied, is given, including but not limited, with respect to the accuracy, correctness, reliability and fitness for a particular purpose of the information. This document may be revised by u-blox at any time. For most recent documents, visit www.u-blox.com.

Copyright © 2021, u-blox AG.

u-blox is a registered trademark of u-blox Holding AG in the EU and other countries

Preface

u-blox Technical Documentation

As part of our commitment to customer support, u-blox maintains an extensive volume of technical documentation for our products. In addition to our product-specific technical data sheets, the following manuals are available to assist u-blox customers in product design and development.

- **GPS Compendium:** This document, also known as the GPS book, provides a wealth of information regarding generic questions about GPS system functionalities and technology.
- **Receiver Description including Protocol Specification:** Messages, configuration and functionalities of the u-blox 7 software releases and positioning modules are explained in this document.
- **Hardware Integration Manuals:** This manual provides hardware design instructions and information on how to set up production and final product tests.
- **Application Note:** These documents provide general design instructions and information that applies to all u-blox GPS/GNSS positioning modules.

How to use this Manual

The MAX-7 and NEO-7 Hardware Integration Manual provides the necessary information to successfully design-in and configure these u-blox 7-based positioning modules. This manual has a modular structure. It is not necessary to read it from beginning to end.

The following symbols are used to highlight important information within the manual:



An index finger points out key information pertaining to module integration and performance.



A warning symbol indicates actions that could negatively influence or damage the module.

Questions

If you have any questions about u-blox 7 Hardware Integration, please:

- Read this manual carefully.
- Contact our information service on the homepage <http://www.u-blox.com>
- Read the questions and answers on our FAQ database on the homepage <http://www.u-blox.com>
- Technical Support

Worldwide Web

Our website (www.u-blox.com) is a rich pool of information. Product information, technical documents and helpful FAQ are available 24h a day.

By E-mail

If you have technical problems or cannot find the required information in the provided documents, contact the closest Technical Support office. To ensure that we process your request as soon as possible, use our service pool email addresses rather than personal staff email addresses. Contact details are at the end of the document.

Helpful Information when Contacting Technical Support

When contacting Technical Support please have the following information ready:

- Receiver type (e.g. NEO-7N-0-000), Datacode (e.g. 172100.0100.000) and firmware version (e.g. ROM1.0)
- Receiver configuration
- Clear description of your question or the problem together with a u-center logfile
- A short description of the application
- Your complete contact details

Contents

Preface	3
Contents	4
1 Quick reference	7
2 Hardware description	8
2.1 Overview	8
2.2 Architecture	8
2.3 Operating modes	8
2.3.1 Continuous Mode	8
2.3.2 Power Save Mode	9
2.4 Configuration	9
2.4.1 Electrical Programmable Fuse (eFuse)	9
2.5 Connecting power	10
2.5.1 VCC: Main supply voltage	10
2.5.2 VCC_IO: IO supply voltage (MAX-7)	10
2.5.3 V_BCKP: Backup supply voltage	10
2.5.4 VDD_USB: USB interface power supply (NEO-7)	11
2.5.5 VCC_RF: Output voltage RF section	11
2.5.6 V_ANT: Antenna supply (MAX-7W)	11
2.6 Interfaces	11
2.6.1 UART	11
2.6.2 USB	12
2.6.3 Display Data Channel (DDC)	13
2.6.4 SPI (NEO-7)	13
2.7 I/O pins	13
2.7.1 RESET_N: Reset input	13
2.7.2 EXTINT: External interrupt	14
2.7.3 D_SEL: Interface select (NEO-7)	14
2.7.4 TX Ready signal	14
2.7.5 ANT_ON: Antenna ON (LNA enable) (NEO-7N, MAX-7Q, MAX-7C)	14
2.7.6 Antenna Short circuit detection (MAX-7W)	14
2.7.7 Antenna open circuit detection	14
2.7.8 Time pulse	14
3 Design	15

3.1	Design checklist.....	15
3.1.1	Schematic checklist.....	15
3.1.2	Layout checklist.....	15
3.1.3	Antenna checklist.....	16
3.2	Design considerations for minimal designs.....	16
3.2.1	Minimal design (NEO-7N).....	17
3.2.2	Minimal design (MAX-7Q).....	18
3.3	Layout.....	20
3.3.1	Footprint and paste mask.....	20
3.3.2	Placement.....	21
3.3.3	Antenna connection and ground plane design.....	21
3.3.4	General design recommendations:.....	23
3.3.5	Antenna micro strip.....	23
3.4	Antenna and Antenna supervision.....	24
3.4.1	Antenna design with passive antenna.....	24
3.4.2	Active antenna design without antenna supervisor (NEO-7N/7M/7P, MAX-7C/7Q).....	25
3.4.3	Antenna design with active antenna using antenna supervisor (MAX-7W).....	26
3.4.4	Design with GLONASS / GPS active antenna.....	31
3.4.5	Design with GLONASS / GPS passive antenna.....	32
3.5	Recommended parts.....	33
3.5.1	Recommended GPS & GLONASS active antenna (A1).....	34
3.5.2	Recommended GPS & GLONASS passive patch antenna.....	34
3.5.3	Recommended GPS & GLONASS passive chip antenna.....	34
4	INPAQ (www.inpaq.com.tw).....	34
5	5.2 x 3.7 x 0.7 mm GPS+GLONASS.....	34
6	Migration to u-blox-7 modules.....	35
6.1	Migrating u-blox 6 designs to a u-blox 7 module.....	35
6.2	Hardware migration.....	35
6.2.1	Hardware compatibility:.....	35
6.2.2	Hardware migration NEO-6 -> NEO-7.....	36
6.2.3	Hardware migration MAX-6 -> MAX-7.....	39
6.3	Software migration.....	40
6.3.1	Software compatibility.....	40
6.3.2	Messages no longer supported.....	40
7	Product handling.....	41
7.1	Packaging, shipping, storage and moisture preconditioning.....	41
7.1.1	Population of Modules.....	41
7.2	Soldering.....	41

7.2.1	Soldering paste.....	41
7.2.2	Reflow soldering	41
7.2.3	Optical inspection.....	42
7.2.4	Cleaning.....	42
7.2.5	Repeated reflow soldering	43
7.2.6	Wave soldering.....	43
7.2.7	Hand soldering	43
7.2.8	Rework	43
7.2.9	Conformal coating.....	43
7.2.10	Casting	44
7.2.11	Grounding metal covers	44
7.2.12	Use of ultrasonic processes	44
7.3	EOS/ESD/EMI precautions.....	44
7.3.1	Electrostatic discharge (ESD).....	44
7.3.2	ESD handling precautions	44
7.3.3	ESD protection measures	45
7.3.4	Electrical Overstress (EOS).....	46
7.3.5	EOS protection measures	46
7.3.6	Electromagnetic interference (EMI)	46
7.3.7	Applications with cellular modules.....	47
8	Product testing	50
8.1	u-blox in-series production test.....	50
8.2	Test parameters for OEM manufacturer	50
8.3	System sensitivity test.....	51
8.3.1	Guidelines for sensitivity tests.....	51
8.3.2	'Go/No go' tests for integrated devices	51
A	Appendix	52
A.1	Abbreviations.....	52
A.2	Design-in recommendations in combination with cellular operation.....	53
	Related documents.....	54
	Revision history	54
	Contact.....	55

1 Quick reference

When using this manual for a design, make sure you also have the data sheet for the specific positioning module (see Related documents).

For information about migration, see sections 4.2.3 (MAX-7) and 4.2.2 (NEO-7).

Layout	Power	Interfaces	I/Os	Antenna
See section 3.3	See sections 2.3 and 2.4	See section 2.6	See section 2.7	See sections 2.5.6 and 3.4

Table 1: Quick guide to this document

2 Hardware description

2.1 Overview

u-blox 7 modules are standalone GNSS positioning modules featuring the high performance u-blox 7 positioning engine. Available in industry standard form factors in leadless chip carrier (LCC) packages, they are easy to integrate and they combine exceptional positioning performance with highly flexible power, design, and connectivity options. SMT pads allow fully automated assembly with standard pick & place and reflow-soldering equipment for cost-efficient, high-volume production enabling short time-to-market.



For product features see the module data sheet.



To determine which u-blox product best meets your needs, see the product selector tables on the u-blox website (www.u-blox.com).

2.2 Architecture

u-blox 7 modules consist of two functional parts - the RF block and the digital block (see Figure 1).

The RF block includes the input matching elements, the SAW band pass filter, the integrated LNA and the oscillator, while the digital block contains the u-blox 7 GNSS engine, the RTC crystal and additional elements such as the optional FLASH Memory for enhanced programmability and flexibility.

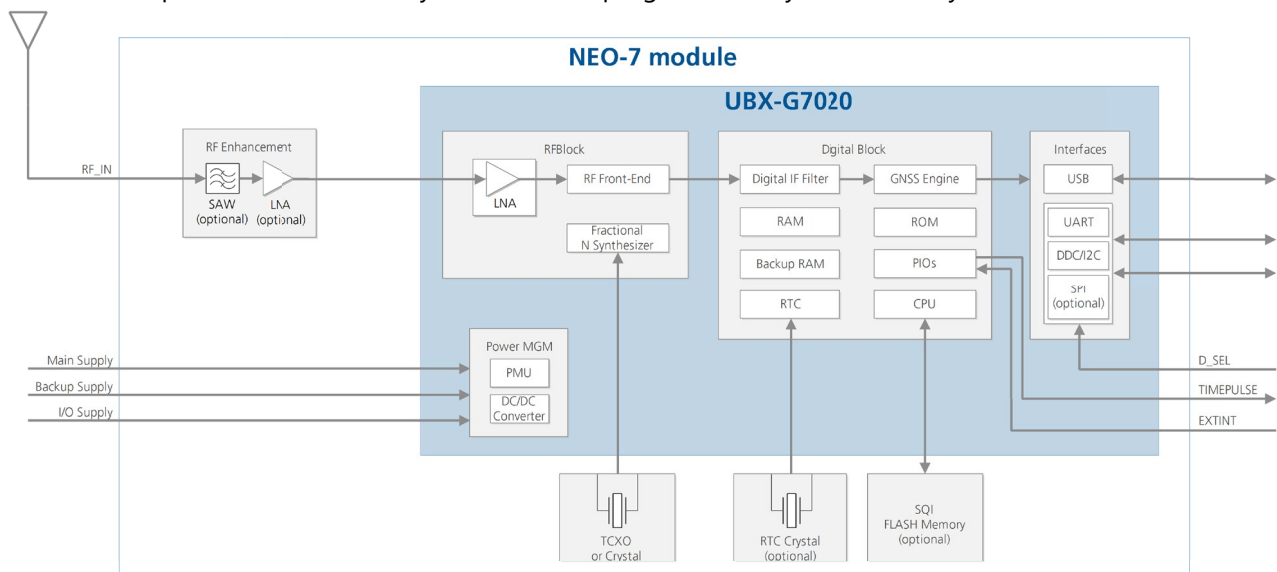

Figure 1: u-blox-7 block diagram

2.3 Operating modes

u-blox receivers support different power modes. These modes represent strategies of how to control the acquisition and tracking engines in order to achieve either the best possible performance or good performance with reduced power consumption.

2.3.1 Continuous Mode

During a cold start, a receiver in Continuous Mode continuously deploys the acquisition engine to search for all satellites. Once the receiver can calculate a position and track a sufficient number of satellites, the acquisition engine powers off, resulting in significant power savings. The tracking engine continuously tracks acquired satellites and acquires other available or emerging satellites. Whenever the receiver can no longer calculate a

position or the number of satellites tracked is below the sufficient number, the acquisition engine powers on again to guarantee a quick reacquisition. Even if the acquisition engine powers off, the tracking engine continues to acquire satellites.

 For best performance, use **continuous mode**.

2.3.2 Power Save Mode

Two Power Save Mode (**PSM**) operations called **ON/OFF** and **Cyclic tracking** are available. These use different ways to reduce the average current consumption in order to match the needs of the specific application. PSM operations are set and configured using serial commands. For more information, see the *u-blox 7 Receiver Description Including Protocol Specification* [4].

The system can shut down an optional external LNA using the ANT_ON signal in order to optimize power consumption, see section 2.7.5.

 Using the USB Interface is not recommended with Power Save Mode since the USB standard does not allow a device to be non-responsive. Thus, it is not possible to have full advantage of Power Save Mode operations in terms of saving current consumption.

 Power Save Mode is not supported in GLONASS mode.

2.4 Configuration

The configuration settings can be modified using UBX protocol configuration messages. The modified settings remain effective until power-down or reset. If these settings have been stored in BBR (Battery Backed RAM), then the modified configuration will be retained, as long as the backup battery supply is not interrupted.

Configuration can be saved permanently in SQL flash.

2.4.1 Electrical Programmable Fuse (eFuse)

u-blox 7 includes an integrated eFuse memory for permanently saving configuration settings.

If no external FLASH memory is available, the eFuse memory can also be used to store the configuration. The customer can program the eFuse.

 **eFuse is One-Time-Programmable; it cannot be changed if it has been programmed once.**

String to change the default Baud rate:

USB self powered / UART Baud Rate 1200	B5 62 06 41 09 00 01 01 30 81 00 00 00 00 FE 01 22
USB self powered / UART Baud Rate 2400	B5 62 06 41 09 00 01 01 30 81 00 00 00 00 FD 00 21
USB self powered / UART Baud Rate 4800	B5 62 06 41 09 00 01 01 30 81 00 00 00 00 FC FF 20
USB self powered / UART Baud Rate 9600	B5 62 06 41 09 00 01 01 30 81 00 00 00 00 FF 02 23
USB self powered / UART Baud Rate 19200	B5 62 06 41 09 00 01 01 30 81 00 00 00 00 FB FE 1F
USB self powered / UART Baud Rate 38400	B5 62 06 41 09 00 01 01 30 81 00 00 00 00 FA FD 1E
USB self powered / UART Baud Rate 57600	B5 62 06 41 09 00 01 01 30 81 00 00 00 00 F9 FC 1D
USB self powered / UART Baud Rate 115200	B5 62 06 41 09 00 01 01 30 81 00 00 00 00 F8 FB 1C

USB bus powered / UART Baud Rate 1200	B5 62 06 41 09 00 01 01 30 81 00 00 00 00 F6 F9 1A
USB bus powered / UART Baud Rate 2400	B5 62 06 41 09 00 01 01 30 81 00 00 00 00 F5 F8 19
USB bus powered / UART Baud Rate 4800	B5 62 06 41 09 00 01 01 30 81 00 00 00 00 F4 F7 18
USB bus powered / UART Baud Rate 9600	B5 62 06 41 09 00 01 01 30 81 00 00 00 00 F7 FA 1B
USB bus powered / UART Baud Rate 19200	B5 62 06 41 09 00 01 01 30 81 00 00 00 00 F3 F6 17
USB bus powered / UART Baud Rate 38400	B5 62 06 41 09 00 01 01 30 81 00 00 00 00 F2 F5 16
USB bus powered / UART Baud Rate 57600	B5 62 06 41 09 00 01 01 30 81 00 00 00 00 F1 F4 15
USB bus powered / UART Baud Rate 115200	B5 62 06 41 09 00 01 01 30 81 00 00 00 00 F0 F3 14

To set the default Vendor or Vendor ID, you will need the specific string. To obtain the **USB Vendor ID** or **USB Vendor string**, contact the the nearest Technical Support office by email. You will find the Contact details at the end of the document.

2.5 Connecting power

u-blox 7 positioning modules have up to five power supply pins: **VCC**, **VCC_IO**, **V_BCKP**, **V_ANT** and **VDD_USB**.

2.5.1 VCC: Main supply voltage

The **VCC** pin provides the main supply voltage. During operation, the current drawn by the module can vary by some orders of magnitude, especially if enabling low-power operation modes. For this reason, it is important that the supply circuitry be able to support the peak power (see datasheet for specification) for a short time.

Some u-blox 7 modules integrate a DC/DC converter. This allows reduced power consumption, especially when using a main supply voltage above 2.5 V.



When switching from backup mode to normal operation or at start-up, u-blox 7 modules must charge the internal capacitors in the core domain. In certain situations, this can result in a significant current draw. For low power applications using Power Save and backup modes it is important that the power supply or low ESR capacitors at the module input can deliver this current/charge.



Use a proper GND concept. Do not use any resistors or coils in the power line. For ground plane design see section 3.3.3.

2.5.2 VCC_IO: IO supply voltage (MAX-7)

VCC_IO from the host system supplies the digital I/Os. The wide range of **VCC_IO** allows seamless interfacing to standard logic voltage levels independent of the **VCC** voltage level. In many applications, **VCC_IO** is simply connected to the main supply voltage.



Without a **VCC_IO** supply, the system will remain in reset state.

2.5.3 V_BCKP: Backup supply voltage

In case of a power failure on the module supply, the real-time clock (RTC) and battery backed RAM (BBR) are supplied by **V_BCKP**. Use of valid time and the GNSS orbit data at start up will improve the GNSS performance

i.e. enables hot starts, warm starts, AssistNow Autonomous and AssistNow Offline. If no backup battery is connected, the module performs a cold start at power up.



Avoid high resistance on the **V_BCKP** line: During the switch from main supply to backup supply a short current adjustment peak can cause high voltage drop on the pin with possible malfunctions.



If no backup supply voltage is available, connect the **V_BCKP** pin to **VCC_IO** (or to **VCC** if not available).



As long as the u-blox 7 module is supplied to **VCC** and **VCC_IO**, the backup battery is disconnected from the RTC and the BBR to avoid unnecessary battery drain (see Figure 2). In this case, **VCC** supplies power to the RTC and BBR.

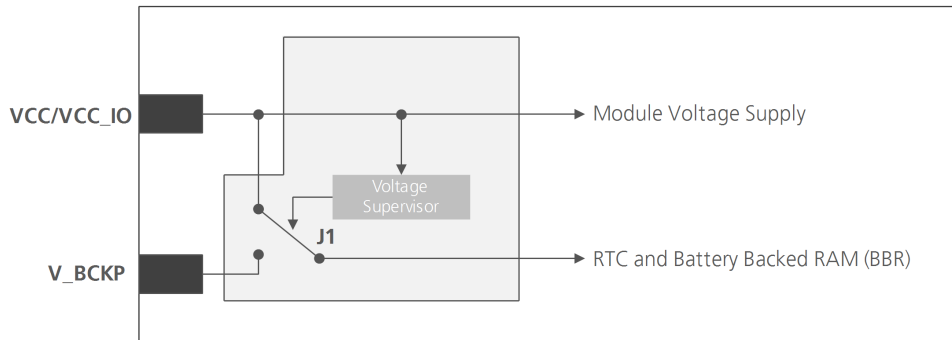

Figure 2: Backup battery and voltage (for exact pin orientation, see data sheet)

2.5.3.1 RTC derived from the system clock; “Single Crystal” feature (MAX-7C)

On MAX-7C, the reference frequency for the RTC clock can be internally derived from the crystal system clock frequency (26 MHz) when in Hardware Backup Mode. This feature is called “single crystal” operation. The backup battery supplies the crystal via **V_BCKP** in the event that **VDD_IO** fails to provide power to derive and maintain the RTC clock. This makes MAX-7C a more cost efficient solution, at the expense of a higher backup current, compared to the usage of an ordinary RTC crystal on other MAX-7 variants. The capacity of the backup battery at **V_BCKP** must be increased accordingly if Hardware Backup Mode is needed.

2.5.4 VDD_USB: USB interface power supply (NEO-7)

VDD_USB supplies the USB interface. If the USB interface is not used, the **VDD_USB** pin must be connected to GND. For more information about correctly handling the **VDD_USB** pin, see section 2.6.2.1.

2.5.5 VCC_RF: Output voltage RF section

The **VCC_RF** pin can supply an active antenna or external LNA. For more information, see section 3.4.3.2.

2.5.6 V_ANT: Antenna supply (MAX-7W)

The **V_ANT** pin is available to provide antenna bias voltage to supply an optional external active antenna. For more information, see section 3.4.3.2.



If not used, connect the **V_ANT** pin to GND.

2.6 Interfaces

2.6.1 UART

u-blox 7 positioning modules include a Universal Asynchronous Receiver Transmitter (UART) serial interface **RxD/TxD** supporting configurable baud rates. The baud rates supported are specified in the *u-blox 7 Receiver Description Including Protocol Specification* [4]

The signal output and input levels are 0 V to **VCC** for NEO-7 and 0 V to **VCC_IO** for MAX-7 modules. An interface based on RS232 standard levels (+/- 12 V) can be implemented using level shifters such as Maxim MAX3232. Hardware handshake signals and synchronous operation are not supported.

2.6.2 USB

A USB version 2.0 FS (Full Speed, 12 Mb/s) compatible interface is available for communication as an alternative to the UART. The **USB_DP** integrates a pull-up resistor to signal a full-speed device to the host. The **VDD_USB** pin supplies the USB interface.

u-blox provides Microsoft® certified USB drivers for Windows XP, Windows Vista, and Windows 7 operating systems (also Windows 8 compatible). These drivers are available at www.u-blox.com.

2.6.2.1 USB external components

The USB interface requires some external components to implement the physical characteristics required by the USB 2.0 specification. These external components are shown in Figure 3 and listed in Table 2. To comply with USB specifications, VBUS must be connected through an LDO (U1) to pin **VDD_USB** on the module.

If the USB device is **self-powered**, the power supply (**VCC**) can be turned off and the digital block is not powered. In this case, since VBUS is still available, the USB host would still receive the signal indicating that the device is present and ready to communicate. This should be avoided by disabling the LDO (U1) using the enable signal (EN) of the VCC-LDO or the output of a voltage supervisor. Depending on the characteristics of the LDO (U1) it is recommended to add a pull-down resistor (R11) at its output to ensure VDD_USB is not floating if the LDO (U1) is disabled or the USB cable is not connected i.e. VBUS is not supplied.

If the device is **bus-powered**, LDO (U1) does not need an enable control.

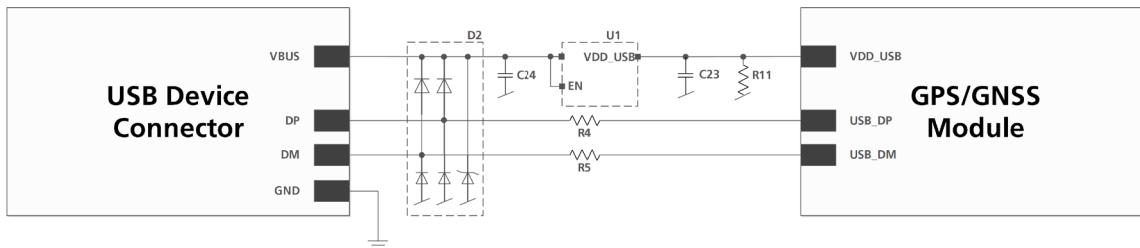

Figure 3: USB Interface

Name	Component	Function	Comments
U1	LDO	Regulates VBUS (4.4 ...5.25 V) down to a voltage of 3.3 V.	Almost no current requirement (~1 mA) if the GNSS receiver is operated as a USB self-powered device, but if bus-powered LDO (U1) must be able to deliver the maximum current. For the peak supply current, see a low-cost DC/DC converter such as LTC3410 from Linear Technology.
C23, C24	Capacitors		Required according to the specification of LDO U1
D2	Protection diodes	Protect circuit from overvoltage / ESD when connecting.	Use low capacitance ESD protection such as ST Microelectronics USBLC6-2.
R4, R5	Serial termination resistors	Establish a full-speed driver impedance of 28...44 Ω	A value of 27 Ω is recommended.
R11	Resistor		1 kΩ is recommended for USB self-powered setup. For bus-powered setup, R11 can be ignored.

Table 2: Summary of USB external components

2.6.3 Display Data Channel (DDC)

An I²C compatible Display Data Channel (DDC) interface is available with u-blox 7 modules for serial communication with an external host CPU. The interface only supports operation in slave mode (master mode is not supported). The DDC protocol and electrical interface are fully compatible with the Fast-Mode of the I²C industry standard. DDC pins **SDA** and **SCL** have internal pull-up resistors.

For more information about the DDC implementation, see the *u-blox 7 Receiver Description Including Protocol Specification* [4]. For bandwidth information, see the Data Sheet. For timing, parameters consult the *I²C-bus specification* [9].

The u-blox 7 DDC interface supports serial communication with u-blox cellular modules. See the specification of the applicable cellular module to confirm compatibility.

With u-blox 7, when reading the DDC internal register at address 0xFF (messages transmit buffer), the master must not set the reading address before every byte is accessed, as this could cause a faulty behavior. After every byte is read from register 0xFF the internal address counter is incremented by one, saturating at 0xFF. Therefore, subsequent reads can be performed continuously.

2.6.4 SPI (NEO-7)

With NEO-7 modules, an SPI interface is available for communication to a host CPU.

SPI is not available in the default configuration, because its pins are shared with the UART and DDC interfaces. The SPI interface can be enabled by connecting D_SEL to ground (NEO-7) (see section 2.7.3). For speed and clock frequency see the Data Sheet.

Figure 4 shows how to connect a u-blox GNSS receiver to a host/master. The signal on the pins must meet the conditions specified in the Data Sheet.

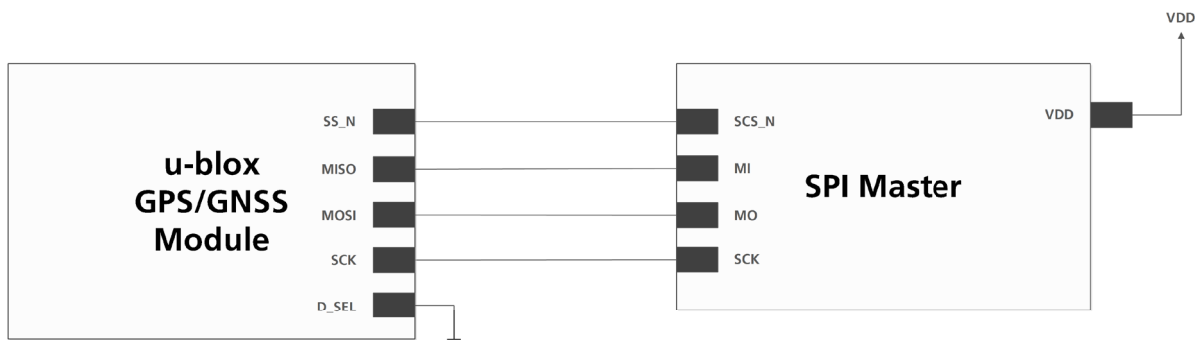

Figure 4: Connecting to SPI Master

VCC_IO must have the same voltage level as the host.

2.7 I/O pins

2.7.1 RESET_N: Reset input

Driving **RESET_N** low activates a hardware reset of the system. Use this pin only to reset the module. Do not use **RESET_N** to turn the module on and off, since the reset state increases power consumption. With u-blox 7 **RESET_N** is an input only.

2.7.2 EXTINT: External interrupt

EXTINT is an external interrupt pin with fixed input voltage thresholds with respect to **VCC** or **VCC_IO** (see the data sheet for more information). It can be used for wake-up functions in Power Save Mode on all u-blox 7 modules and for aiding. Leave open if unused.

2.7.3 D_SEL: Interface select (NEO-7)

The **D_SEL** pin, available on all NEO-7 modules, selects the available interfaces. SPI cannot be used simultaneously with UART/DDC.

If open, UART and DDC are available. If pulled low, the SPI Interface is available.

Pin	D_SEL pin open	D_SEL pin low
18	DDC Data	SPI CS_N
19	DDC Clock	SPI SCK
20	TxD	SPI MISO
21	RxD	SPI MOSI

Table 3: D_SEL pin on NEO-7

2.7.4 TX Ready signal

The TX Ready signal indicates that the receiver has data to transmit. A listener can wait on the TX Ready signal instead of polling the DDC or SPI interfaces. The UBX-CFG-PRT message lets you configure the polarity and the number of bytes in the buffer before the TX Ready signal goes active. The TX Ready signal can be mapped to UART TXD (PIO 06). The TX Ready function is disabled by default.



The TX-ready functionality can be enabled and configured by proper AT commands sent to the involved u-blox cellular module supporting the feature. For more information see *GPS Implementation and Aiding Features in u-blox wireless modules [10]*.

2.7.5 ANT_ON: Antenna ON (LNA enable) (NEO-7N, MAX-7Q, MAX-7C)

In Power Save Mode, the system can turn on/off an optional external LNA using the ANT_ON signal in order to optimize power consumption. A pull-down resistor (10 kOhm) is required to ensure correct operation in backup mode of the ANT_ON signal.

2.7.6 Antenna Short circuit detection (MAX-7W)

The MAX-7W module includes internal short circuit antenna detection. For more information, see *section 3.4.3.2*.

2.7.7 Antenna open circuit detection

2.7.7.1 Antenna open circuit detection (MAX-7)

Antenna open circuit detection (OCD) is not activated by default on the MAX-7 module. OCD can be mapped to PIO13 (**EXTINT**). For more information about how to implement OCD, see *section 3.4.3.3*. To learn how to configure OCD see the *u-blox 7 Receiver Description including Protocol Specification [4]*.

2.7.8 Time pulse

A configurable time pulse signal is available with all u-blox 7 modules. By default, the time pulse signal is configured to 1 pulse per second. For more information see the *u-blox 7 Receiver Description including Protocol Specification [4]*.

3 Design

3.1 Design checklist

Designing-in a u-blox 7 module is easy, especially when based on a u-blox reference design. Nonetheless, it pays to do a quick sanity check of the design. This section lists the most important items for a simple design check. The design checklist can also help to avoid an unnecessary PCB respin and achieve the best possible performance. Follow the design checklists when developing any u-blox 7 GNSS applications. This can significantly reduce development time and costs.

3.1.1 Schematic checklist

- If required, does your schematic allow for using different module variants? See the u-blox website (www.u-blox.com) to compare the available features of u-blox 7 GNSS modules.
- Plan the use of a second interface (Test points on UART, DDC or USB) for firmware updates or as a service connector.

Power supply requirements

- GNSS positioning modules require a stable power supply. In selecting a strategy to achieve a clean and stable power supply, any resistance in the **VCC** supply line can negatively influence performance. Consider the following points:
 - Wide power lines or even power planes are preferred.
 - Avoid resistive components in the power line (e.g. narrow power lines, coils, resistors, etc.).
 - Placing a filter or other source of resistance at **VCC** can create significantly longer acquisition times.
 - For ground plane design, see section 3.3.3.
- Are all power supplies (**VCC**, VDD_USB) within the specified range? (See the data sheet: *NEO-7* [1] or *MAX-7* [2])
- Compare the peak supply current consumption of your u-blox 7 module with the specification of the power supply. (See the data sheet for more information.)
- At the module input, use low ESR capacitors that can deliver the required current/charge for switching from backup mode to normal operation.

Backup battery

- Use of valid time and the GNSS orbit data at startup will improve the GNSS performance i.e. enables hot starts, warm starts and the AssistNow Autonomous process as well as AssistNow Offline. To make use of these features connect a battery to V_BCKP to continue supplying the backup domain in case of power failure at **VCC_IO**.



If no backup supply voltage is available, connect the **V_BCKP** pin to **VCC_IO** (or to **VCC** if not available).

3.1.2 Layout checklist



See section 3.3.

- Is the GNSS module located according to the recommendation?
- Has the grounding concept been followed?
- Has the micro strip been kept as short as possible?
- Add a ground plane underneath the GNSS module to reduce interference.

- ❑ For improved shielding, add as many vias as possible around the micro strip, around the serial communication lines, underneath the GNSS module etc.
- ❑ Have appropriate EOS/ESD/EMI protection measures been included? This is especially important for designs including cellular modules.

3.1.3 Antenna checklist

- ❑ The total noise figure should be well below 3 dB.
- ❑ If a patch antenna is the preferred antenna, choose a patch of at least 15x15x4 mm for standalone GPS/QZSS, or choose a patch of at least 25x25x4 mm for GPS + GLONASS. For smaller antennas, an LNA with a noise figure <2 dB is recommended. (MAX-7Q, NEO-7N)
- ❑ Make sure the antenna is not placed close to noisy parts of the circuitry. (E.g. micro-controller, display, etc.)
- ❑ To optimize performance in environments with out-of band jamming sources, use an additional SAW filter.
- ❑ The micro strip must be 50 Ω and be routed in a section of the PCB where minimal interference from noise sources can be expected.
- ❑ In case of a multi-layer PCB, use the thickness of the dielectric between the signal and the first GND layer (typically the 2nd layer) for the micro strip calculation.
- ❑ If the distance between the micro strip and the adjacent GND area (on the same layer) does not exceed 5 times the track width of the micro strip, use the "Coplanar Waveguide" model in AppCad to calculate the micro strip and not the "micro strip" model see section 3.3.5
- ❑ Use an external LNA if your design does not include an active antenna when optimal performance is important.



For information on ESD protection for patch antennas and removable antennas, see section 5.3.3 and if you use GPS for design in combination with GSM or other radio then check sections 5.3.5 to 5.3.7.



For more information dealing with interference, issues see the *GPS Antenna Application Note* [6].

3.2 Design considerations for minimal designs

For a minimal design with a u-blox 7 GNSS module, the following functions and pins need consideration:

- Connect the Power supply to **VCC**.
- Connect **VCC_IO** to **VCC** or to the corresponding voltage.
- Assure an optimal ground connection to all ground pins of the module.
- Connect the antenna to **RF_IN** over a 50 Ω line and define the antenna supply (**V_ANT**) for active antennas (internal or external power supply).
- Choose the required serial communication interface (UART, USB, SPI or DDC) and connect the appropriate pins to your application.
- If you need improved start-up or use AssistNow Autonomous in your application, connect a backup supply voltage to **V_BCKP**.



For active antenna design, see section 3.4.2.

3.2.1 Minimal design (NEO-7N)

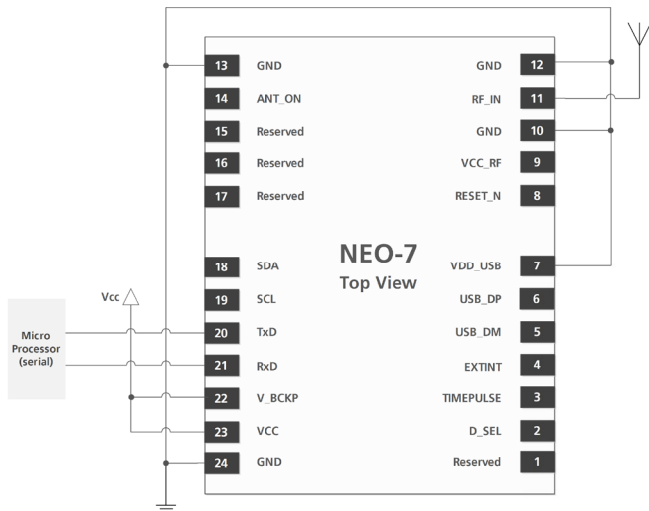

Figure 5: NEO-7 passive antenna design

Function	PIN	No	I/O	Description	Remarks
Power	VCC	23	I	Supply voltage	Provide clean and stable supply.
	GND	10,12,13, 24	I	Ground	Assure a good GND connection to all GND pins of the module, preferably with a large ground plane.
	V_BCKP	22	I	Backup supply voltage	It is recommended to connect a backup supply voltage to V_BCKP in order to enable Warm and Hot Start features on the positioning modules. Otherwise, connect to VCC .
	VDD_USB	7	I	USB power supply	To use the USB interface connect this pin to 3.0 – 3.6 V. If no USB serial port used connect to GND .
Antenna	RF_IN	11	I	GPS signal input from antenna	The connection to the antenna has to be routed on the PCB. Use a controlled impedance of 50 Ω to connect RF_IN to the antenna or the antenna connector. DC block inside.
	VCC_RF	9	O	Output voltage RF section	VCC_RF can be used to power an external active antenna.
UART	TxD	20	O	Serial port/ SPI MISO	Communication interface, Can be programmed as TX Ready for DDC interface. If pin 2 low => SPI MISO.
	RxD	21	I	Serial port / SPI MOSI	Serial input. Internal pull-up resistor to VCC. Leave open if not used. If pin 2 low => SPI MOSI.
USB	USB_DM	5	I/O	USB I/O line	USB bidirectional communication pin. Leave open if unused. Implementations see section 2.6.2.
	USB_DP	6	I/O	USB I/O line	
System	TIMEPULSE	3	O	Time pulse signal	Configurable time pulse signal (one pulse per second by default). Leave open if not used.
	EXTINT	4	I	External interrupt	External Interrupt pin. Internal pull-up resistor to VCC . Leave open if not used.
	SDA	18	I/O	DDC data / SPI CS_N	DDC Data If pin 2 low => SPI chip select.
	SCL	19	I	DDC clock / SPI SCK	DDC Clock. If pin 2 low => SPI clock.
	ANT_ON (NEO-7N)	14	O	ANT_ON	ANT_ON (antenna on) HIGH can be used to turn on and LOW to turn off an optional external LNA.
	RESERVED (NEO-7M)			Reserved	Reserved, leave open.
	RESET_N	8	I	Reset input	Reset input
	D_SEL	2	I	selects the interface	Used to select UART/DDC or SPI Open = UART/DDC; low = SPI
RESERVED	1, 15, 16, 17	-	Reserved	Leave open.	

Table 4: Pinout NEO-7

3.2.2 Minimal design (MAX-7Q)

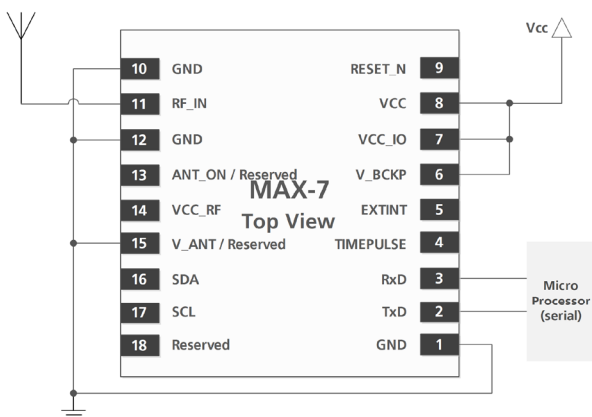

Figure 6: MAX-7 passive antenna design



For information on increasing immunity to jammers such as GSM, see section 5.3.7.

Function	PIN	No	I/O	Description	Remarks
Power	VCC	8	I	Supply voltage	Provide clean and stable supply.
	GND	1,10,12	I	Ground	Assure a good GND connection to all GND pins of the module, preferably with a large ground plane.
	V_BCKP	6	I	Backup supply voltage	Backup supply voltage input pin. Connect to VCC_IO if not used.
Antenna	RF_IN	11	I	GPS signal input from antenna	The connection to the antenna has to be routed on the PCB. Use a controlled impedance of 50 Ω to connect RF_IN to the antenna or the antenna connector. DC block inside.
	VCC_RF	14	O	Output voltage RF section	Can be used for active antenna or external LNA supply.
	ANT_ON (MAX-7C/Q)	13	O	ANT_ON	ANT_ON (antenna on) HIGH can be used to turn on and LOW to turn off an optional external LNA. ANT_ON pin voltage level is VCC_IO
	Reserved (MAX-7W)	-	-	Reserved	Leave open
UART	TXD	2	O	Serial port	UART, leave open if not used, voltage level referred VCC_IO . Can be configured as TX Ready indication for the DDC interface.
	RXD	3	I	Serial port	UART, leave open if not used, voltage level referred VCC_IO
System	TIMEPULSE	4	O	Time pulse signal	Leave open if not used, voltage level referred VCC_IO
	EXTINT	5	I	External interrupt	Leave open if not used, voltage level referred VCC_IO
	SDA	16	I/O	DDC pins	DDC Data. Leave open, if not used.
	SCL	17	I	DDC pins	DDC Clock. Leave open, if not used.
	VCC_IO	7	I	VCCC_IO	IO supply voltage. Input must be always supplied. Usually connect to VCC pin 8
	RESET_N	9	I	Reset	Reset
	V_ANT (MAX-7W)	15	I	Antenna bias voltage	Connect to GND (or leave open) if passive antenna is used. If an active antenna is used, add a 10 Ω resistor in front of V_ANT input to the Antenna Bias voltage or VCC_RF
	Reserved (MAX-7C/Q)	-	-	Reserved	Leave open
Reserved	18	-	Reserved	Leave open	

Table 5: Pinout MAX-7

3.3 Layout

This section provides important information for designing a robust GNSS system.

GNSS signals at the surface of the Earth are about 15 dB below the thermal noise floor. Signal loss from the antenna to RF_IN pin of the module must be minimized as much as possible. When defining a GNSS receiver layout, the placement of the antenna with respect to the receiver, as well as grounding, shielding and jamming from other digital devices, are crucial issues requiring careful consideration.



For all layout and routing figures shown in this section, see the data sheet for exact pin orientation.

3.3.1 Footprint and paste mask

Figure 7 through Figure 10 describe the footprint and provide recommendations for the paste mask for u-blox 7 LCC modules. These are recommendations only and not specifications. Note that the Copper and Solder masks have the same size and position.

To improve the wetting of the half vias, reduce the amount of solder paste under the module and increase the volume outside of the module by defining the dimensions of the paste mask to form a T-shape (or equivalent) extending beyond the Copper mask.

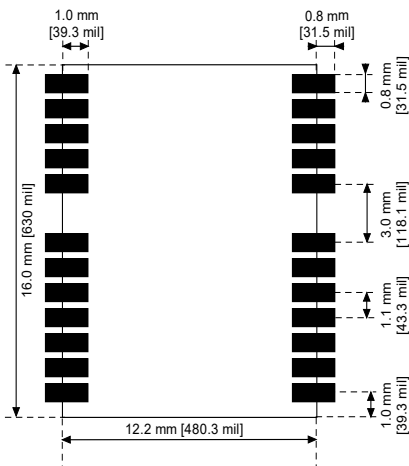

Figure 7: NEO-7 footprint

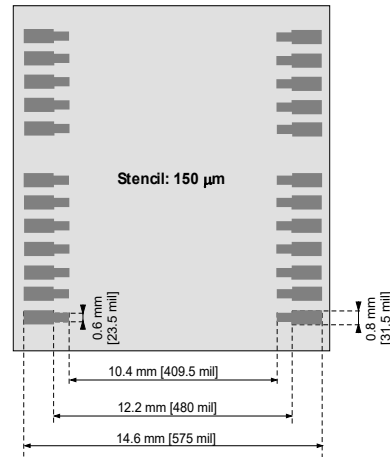

Figure 9: NEO-7 paste mask

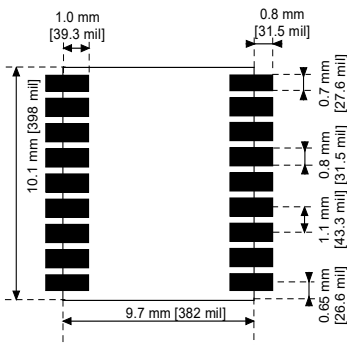

Figure 8: MAX-7 footprint

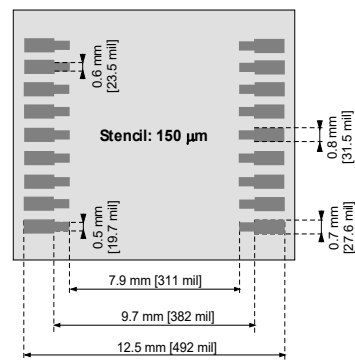

Figure 10: MAX-7 paste mask



MAX Form Factor (10.1 x 9.7 x 2.5): Same Pitch as NEO for all pins: 1.1 mm, but 4 pads in each corner (pin 1, 9, 10 and 18) only 0.7 mm wide instead of 0.8 mm



Consider the paste mask outline when defining the minimal distance to the next component. The exact geometry, distances, stencil thicknesses and solder paste volumes must be adapted to the specific production processes (e.g. soldering) of the customer.

3.3.2 Placement

A very important factor in achieving maximum performance is the placement of the receiver on the PCB. The connection to the antenna must be as short as possible to avoid jamming into the very sensitive RF section.

Make sure that the RF critical circuits are separated from any other digital circuits on the system board. To achieve this, position the module's digital part towards the digital section on the system PCB. Exercise care if placing the receiver in proximity to heat emitting circuitry. The RF part of the receiver is very sensitive to temperature and sudden changes can have an adverse impact on performance.

The RF part of the receiver is a temperature sensitive component. Avoid high temperature drift and air vents near the receiver.

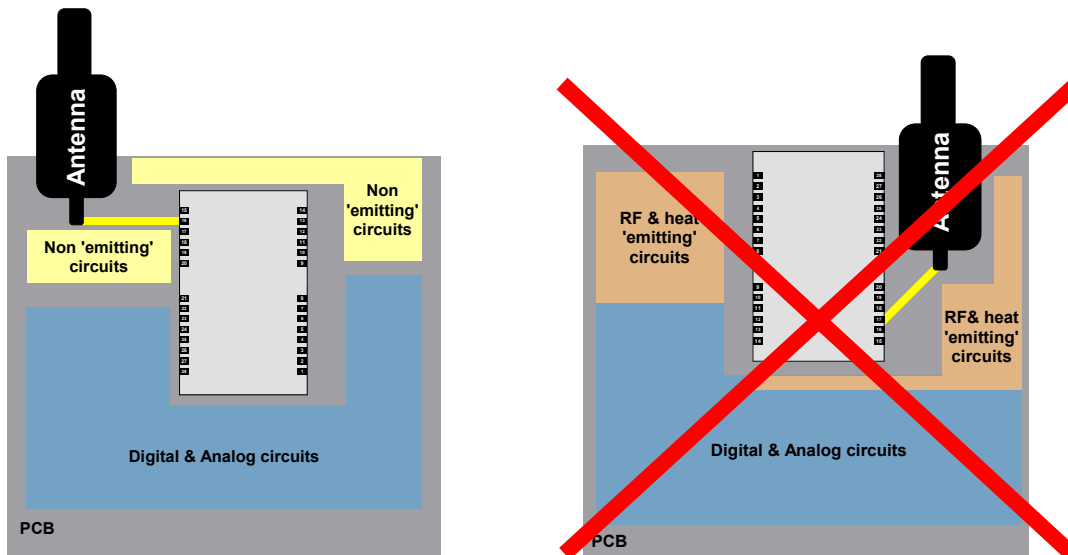

Figure 11: Placement

3.3.3 Antenna connection and ground plane design

u-blox 7 modules can be connected to passive or active antennas. The RF connection is on the PCB and connects the **RF_IN** pin with the antenna feed point or the signal pin of the connector, respectively. Figure 12 illustrates connection to a typical five-pin RF connector. One can see the improved shielding for digital lines as discussed in the *GPS Antenna Application Note* [6]. Depending on the actual size of the ground area, if possible place additional vias in the outer region. In particular, terminate the edges of the ground area with a dense line of vias.

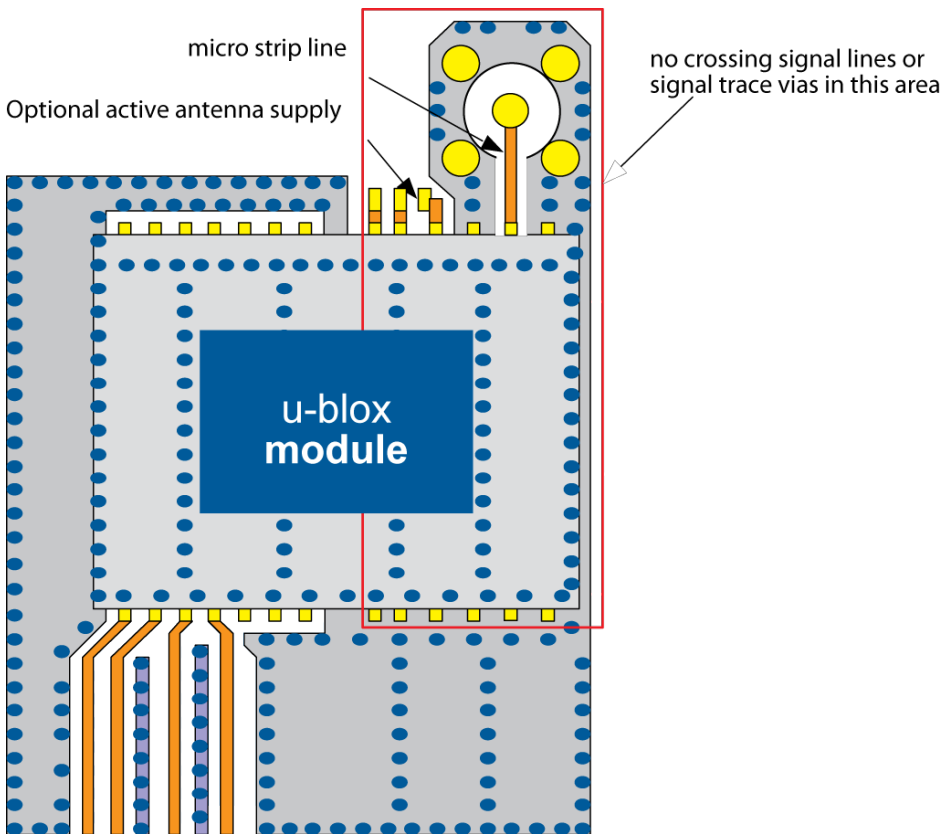

Figure 12: Recommended layout

As seen in Figure 12, an isolated ground area exists around and below the RF connection. This part of the circuit **MUST** be kept as far from potential noise sources as possible. Make certain that no signal lines cross, and that no signal trace vias appear at the PCB surface within the area of the red rectangle. The ground plane should also be free of digital supply return currents in this area. On a multi layer board, the whole layer stack below the RF connection should be kept free of digital lines. This is because even solid ground planes provide only limited isolation.

The impedance of the antenna connection must match the $50\ \Omega$ impedance of the receiver. To achieve an impedance of $50\ \Omega$, the width W of the micro strip has to be chosen depending on the dielectric thickness H , the dielectric constant ϵ_r of the dielectric material of the PCB and on the build-up of the PCB (see *section 3.3.5*). Figure 13 shows two different builds: A 2 Layer PCB and a 4 Layer PCB. The reference ground plane is in both designs on layer 2 (red). Therefore, the effective thickness of the dielectric is different.

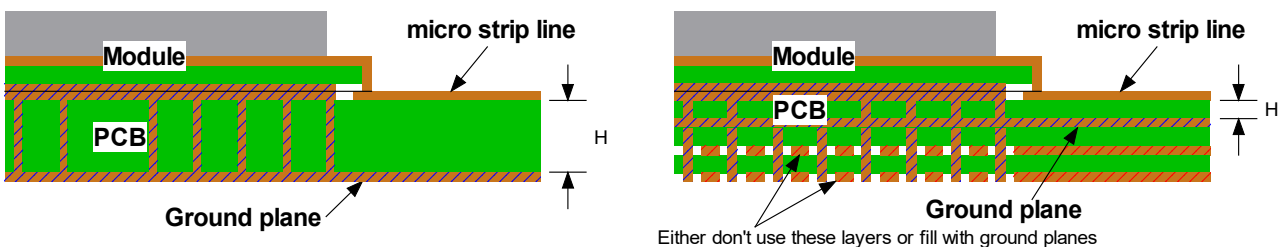

Figure 13: PCB build-up for micro strip line. Left: 2-layer PCB, right: 4-layer PCB

3.3.4 General design recommendations:

- The length of the micro strip line should be kept as short as possible. Lengths over 2.5 cm (1 inch) should be avoided on standard PCB material and without additional shielding.
- For multi-layer boards the distance between micro strip line and ground area on the top layer should at least be as large as the dielectric thickness.
- Routing the RF connection close to digital sections of the design should be avoided.
- To reduce signal reflections, sharp angles in the routing of the micro strip line should be avoided. Chamfers or fillets are preferred for rectangular routing; 45-degree routing is preferred over Manhattan style 90-degree routing.

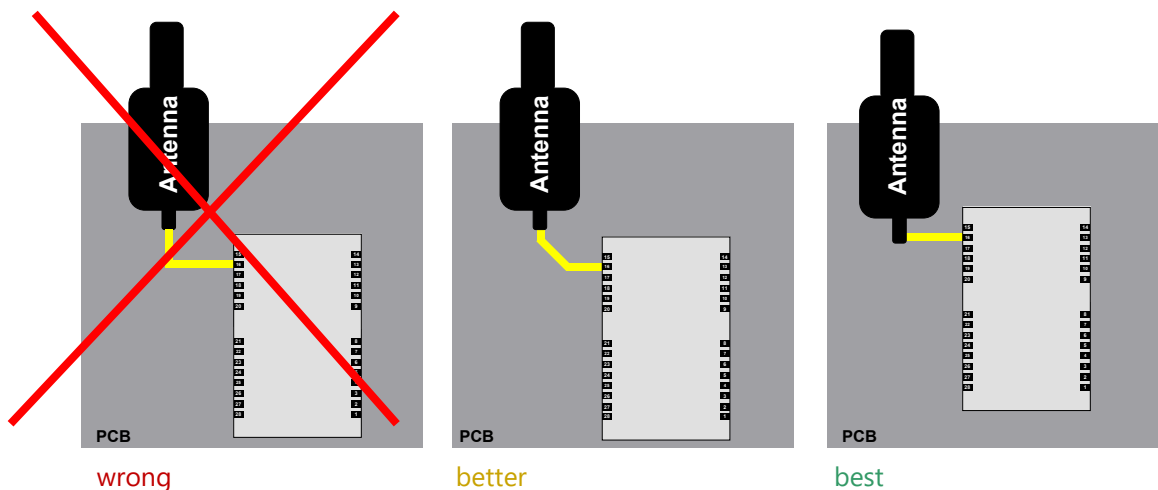

Figure 14: Recommended micro strip routing to RF pin

- Do not route the RF-connection underneath the receiver. The distance of the micro strip line to the ground plane on the bottom side of the receiver is very small (some 100 μm) and has huge tolerances (up to 100%). Therefore, the impedance of this part of the trace cannot be controlled.
- Use as many vias as possible to connect the ground planes.
- In order to avoid reliability hazards, the area on the PCB under the receiver should be entirely covered with solder mask. Vias should not be open. Do not route under the receiver.

3.3.5 Antenna micro strip

There are many ways to design wave-guides on printed circuit boards. A common factor to all is that calculation of the electrical parameters is not straightforward. Freeware tools like AppCAD from Agilent or TXLine from Applied Wave Research, Inc. are of great help in this regard. They can be downloaded from www.agilent.com or www.hp.woodshot.com and www.mwoffice.com.

Micro strip is the most commonly used configuration on printed circuit boards and shown below in Figure 15 and Figure 16. As a rule of thumb, to achieve a 50 Ω line impedance with FR-4 material, the width of the conductor is roughly double the thickness of the dielectric.

Note: For the correct calculation of the micro strip impedance, one does not only need to consider the distance between the top and the first inner layer, but also the distance between the micro strip and the adjacent GND plane on the same layer



Use the Grounded Coplanar Waveguide model for the calculation of the line dimensions.

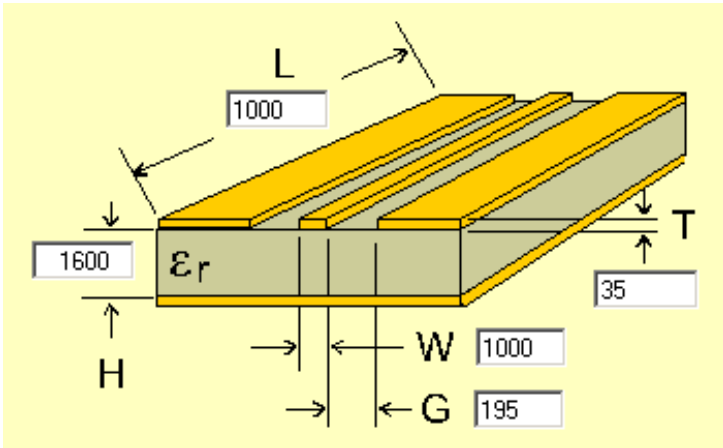

Figure 15: Micro strip on a 2-layer board (Agilent AppCAD Coplanar Waveguide)

Figure 15 shows an example of a 2-layer FR4 board with 1.6 mm thickness (**H**) and a 35 μm (1 ounce) copper cladding (**T**). The thickness of the micro strip is comprised of the cladding (35 μm) plus the plated copper (typically 25 μm). Figure 16 is an example of a multi layer FR4 board with 18 μm (½ ounce) cladding (**T**) and 180 μm dielectric between layer 1 and 2.

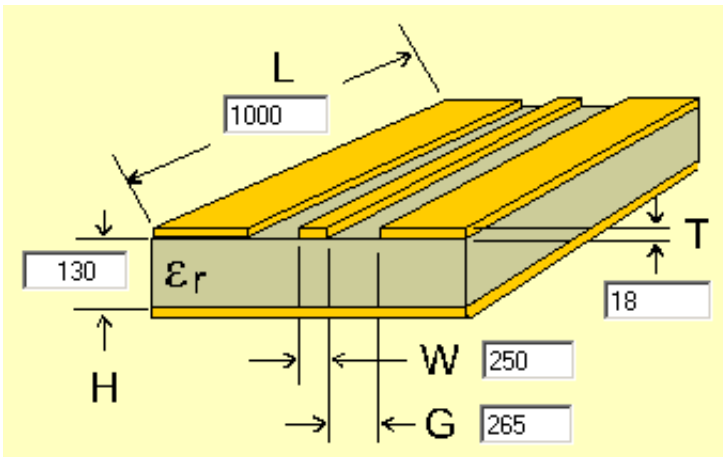

Figure 16: Micro strip on a multi layer board (Agilent AppCAD Coplanar Waveguide)

3.4 Antenna and Antenna supervision

- For all module designs shown in this section, see the data sheet for exact pin orientation.
- For recommended parts, see section 3.5.

3.4.1 Antenna design with passive antenna

A design using a passive antenna requires more attention to the layout of the RF section. Typically, a passive antenna is located near electronic components; therefore, care should be taken to reduce electrical 'noise' that may interfere with the antenna performance. Passive antennas do not require a DC bias voltage and can be directly connected to the RF input pin **RF_IN**. Sometimes, they may also need a passive matching network to match the impedance to 50 Ω .

3.4.1.1 Minimal setup with a good patch antenna

Figure 17 shows a minimal setup for a design with a good GPS patch antenna.



NEO-7N is optimized for immunity to near field cellular signals.

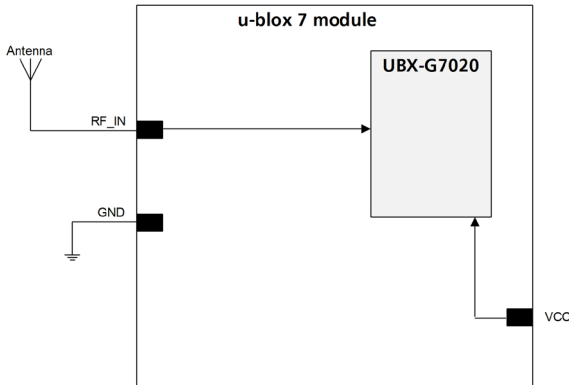

Figure 17: Module design with passive antenna

3.4.1.2 Setup for best performance with passive antenna

Figure 18 shows a design using an external LNA to increase the sensitivity for best performance with passive antenna.

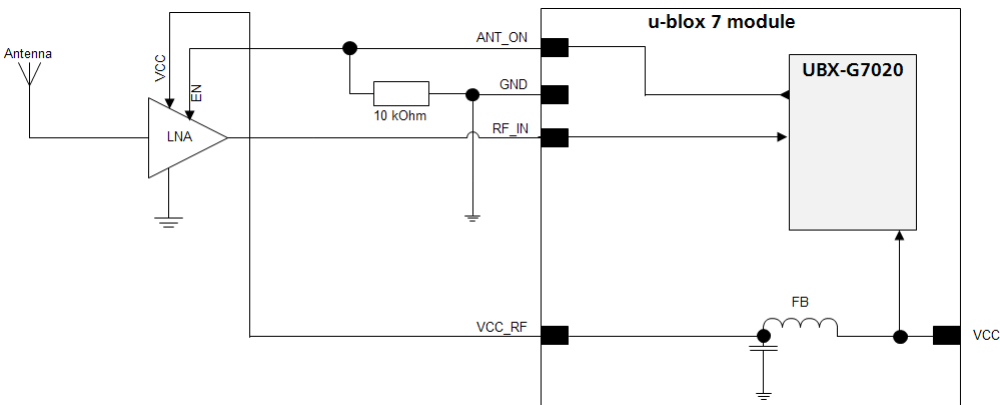

Figure 18: Module design with passive antenna and external LNA

ANT_ON (antenna on) can be used to turn on and off an optional external LNA.

The **VCC_RF** output can be used to supply the LNA with a filtered supply voltage.



A standard GPS LNA has enough bandwidth to amplify GPS and GLONASS signals.

3.4.2 Active antenna design without antenna supervisor (NEO-7N/7M/7P, MAX-7C/7Q)

Active antennas have an integrated low-noise amplifier. Active antennas require a power supply that will contribute to the total GPS system power consumption budget with additional 5 to 20 mA typically.

If the supply voltage of the u-blox 7 receiver matches the supply voltage of the antenna (e.g. 3.0 V), use the filtered supply voltage **VCC_RF** output to supply the antenna. See section 3.4.2.1. This design is used for modules MAX-7C, MAX-7Q, NEO-7N, and NEO-7M in combination with active antenna.

In case of different supply voltage, use a filtered external supply as shown in section 3.4.2.2

3.4.2.1 Active antenna design, VCC_RF used to supply active antenna

Figure 19 shows an active antenna design supplied by VCC_RF.

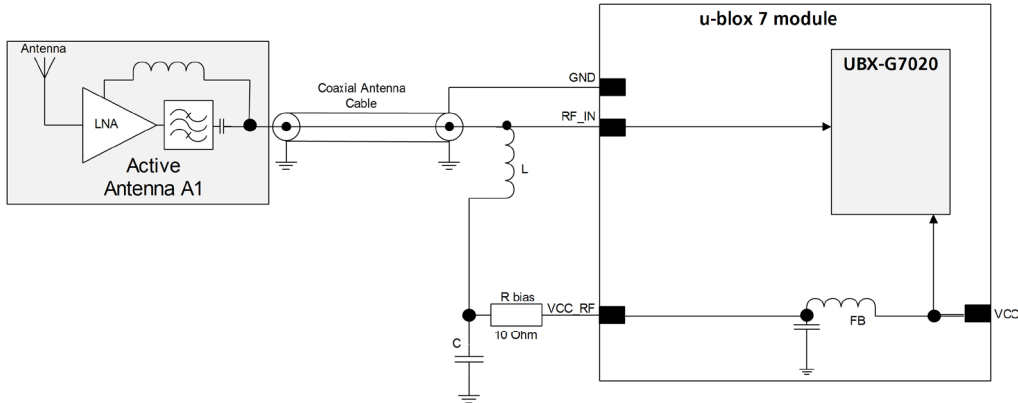

Figure 19: Active antenna design, external supply from VCC_RF

3.4.2.2 Active antenna design powered from external supply

Figure 20 shows a design with direct externally powered active antenna.

This circuit works with all u-blox 7 modules, also with modules without VCC_RF output.

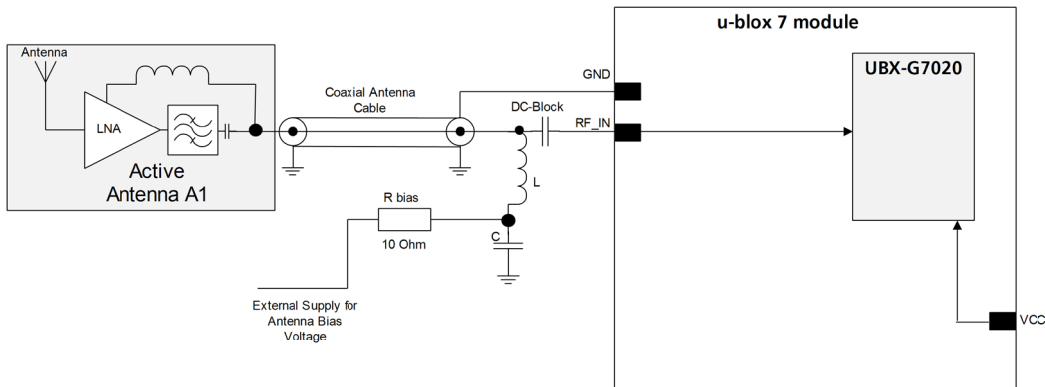

Figure 20: Active antenna design, direct external supply



For recommended parts, see section 3.5.



In case VCC_RF voltage does not match with the antenna supply voltage, use a filtered external supply as shown in Figure 20.

3.4.3 Antenna design with active antenna using antenna supervisor (MAX-7W)

An active antenna supervisor provides the means to check the antenna for open and short circuits and to shut off the antenna supply if a short circuit is detected. The Antenna Supervisor is configured using serial port UBX binary protocol message. Once enabled, the active antenna supervisor produces status messages, reporting in NMEA and/or UBX binary protocol (see section 3.4.3.1). These indicate the particular state of the antenna supervisor shown in the state diagram below (Figure 21).

The current active antenna status can be determined by polling the UBX-MON-HW monitor command. If an antenna is connected, the initial state after power-up is "Active Antenna OK."

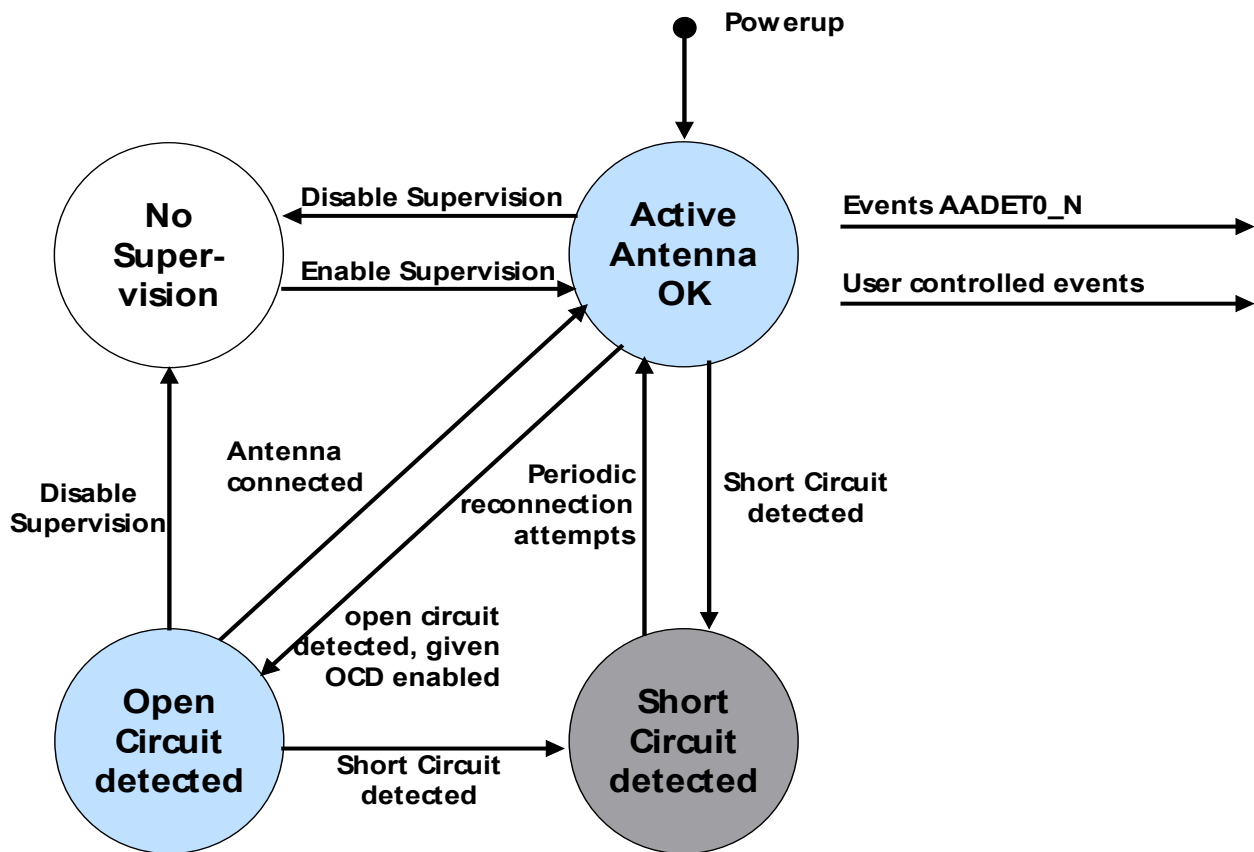

Figure 21: State diagram of active antenna supervisor

The module firmware supports an active antenna supervisor circuit, which is connected to the **AADET_N** pin. For an example of an open circuit detection circuit, see Figure 24. High on pin **AADET_N** means that an external antenna is not connected.

3.4.3.1 Status reporting

At startup, and on every change of the antenna supervisor configuration, the u-blox 7 GPS/GALILEO module will output an NMEA (**\$GPTXT**) or UBX (**INF-NOTICE**) message with the internal status of the antenna supervisor (disabled, short detection only, enabled).

None, one or several of the strings below are part of this message to inform about the status of the active antenna supervisor circuitry (e.g. "**ANTSUPERV= AC SD OD PdoS**").

Abbreviation	Description
AC	Antenna Control (e.g. the antenna will be switched on/ off controlled by the GPS receiver)
SD	Short Circuit Detection Enabled
SR	Short Circuit Recovery Enabled
OD	Open Circuit Detection Enabled
PdoS	Power Down on short

Table 6: Active Antenna Supervisor Message on startup (UBX binary protocol)



To activate the antenna supervisor use the UBX-CFG-ANT message. For further information, refer to the *u-blox 7 Receiver Description Including Protocol Specification* [4].

Similar to the antenna supervisor configuration, the status of the antenna supervisor will be reported in an NMEA (**\$GPTXT**) or UBX (**INF-NOTICE**) message at start-up and on every change.

Message	Description
ANTSTATUS=DONTKNOW	Active antenna supervisor is not configured and deactivated.
ANTSTATUS=OK	Active antenna connected and powered
ANTSTATUS=SHORT	Antenna short
ANTSTATUS=OPEN	Antenna not connected or antenna defective

Table 7: Active antenna supervisor message on startup (NMEA protocol)

3.4.3.2 Module design with active antenna, short circuit protection / detection (MAX-7W)

If a suitably dimensioned series resistor **R_BIAS** is placed in front of pin **V_ANT**, a short circuit can be detected in the antenna supply. This is detected inside the u-blox 7 module and the antenna supply voltage will be immediately shut down. After which, periodic attempts to re-establish antenna power are made by default.

An internal switch (under control of the receiver) can turn off the supply to the external antenna whenever it is not needed. This feature helps to reduce power consumption in power save mode.

 To configure the antenna supervisor use the UBX-CFG-ANT message. For further information see the *u-blox 7 Receiver Description Including Protocol Specification* [4].

 **Short circuits on the antenna input without limitation (**R_BIAS**) of the current can result in permanent damage to the receiver! Therefore, it is mandatory to implement an **R_BIAS** in all risk applications, such as situations where the antenna can be disconnected by the end-user or that have long antenna cables.**

 If the **VCC_RF** voltage does not match the antenna supply voltage, use a filtered external supply as shown in Figure 23.

Supply from VCC_RF (MAX-7W)

Figure 22 shows an active antenna supplied from the u-blox 7 module.

The **VCC_RF** pin can be connected with **V_ANT** to supply the antenna. Note that the voltage specification of the antenna has to match the actual supply voltage of the u-blox module (e.g. 3.0 V), see Figure 22.

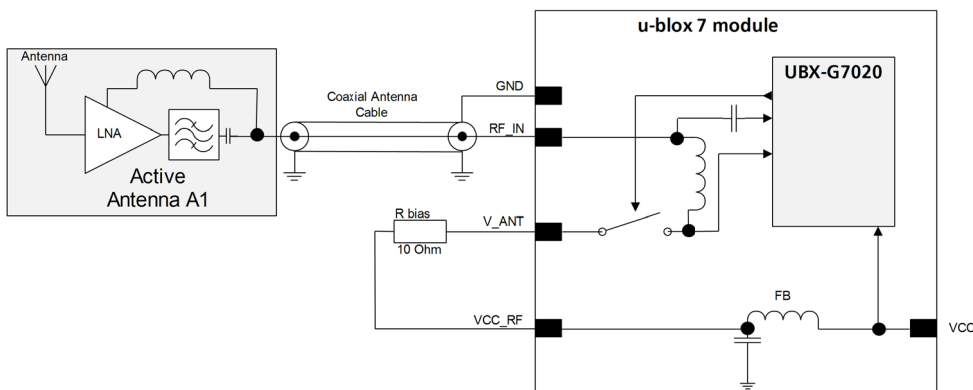

Figure 22: Module design with active antenna, internal supply from VCC_RF

External supply (MAX-7W)

Figure 23 shows an externally powered active antenna design.

Since the external bias voltage is fed into the most sensitive part of the receiver (i.e. the RF input), this supply should be free of noise. Usually, low frequency analog noise is less critical than digital noise of spurious frequencies with harmonics up to the GPS/QZSS band of 1.575 GHz and GLONASS band of 1.602 GHz. Therefore, it is not recommended to use digital supply nets to feed the **V_ANT** pin.

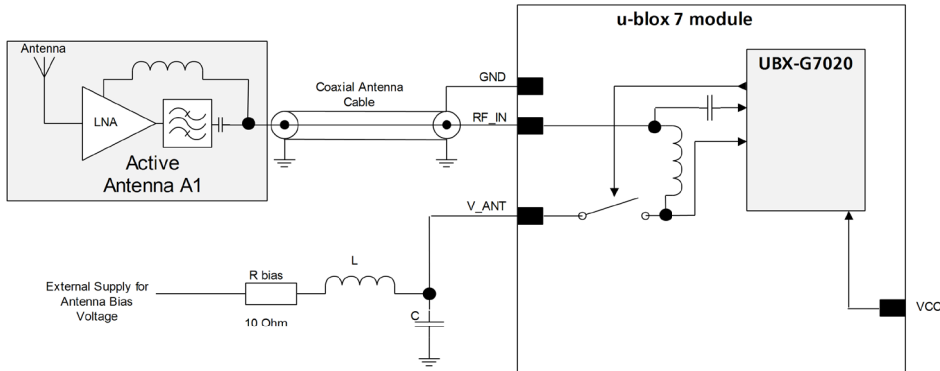

Figure 23: Module design with active antenna, external supply

3.4.3.3 Antenna supervision open circuit detection (OCD) (MAX-7W)

The open circuit detection circuit uses the current flow to detect an open circuit in the antenna. Calculate the threshold current using Equation 1.

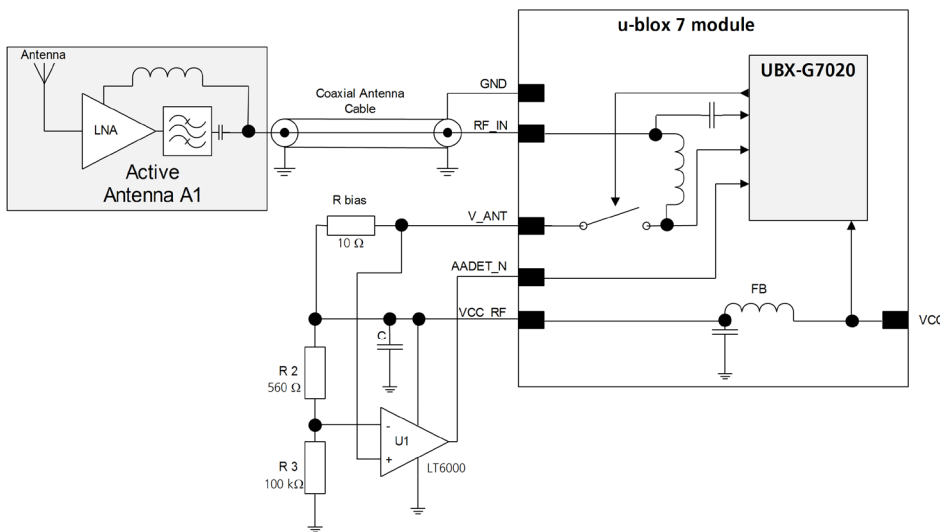

Figure 24: Schematic of open circuit detection

$$I = \left(\frac{R2}{R2 + R3} \right) \cdot V_{cc_RF}$$

Equation 1: Calculation of threshold current for open circuit detection

Antenna open circuit detection (OCD) is not activated by default. It can be enabled by the UBXC-FG-ANT message. This configuration can be sent to the receiver at every startup or can be saved permanently in flash. MAX-7W does not have a dedicated **AADET_N** pin. The **AADET_N** pin can be made available on the **EXINT** pin. To do so, the following command must be sent once and stored permanently to the receiver:

- "B5 62 06 41 0C 00 00 00 03 1F 06 5F 8B B1 FF F6 B7 FF C1 D7".

To enable the OCD feature, the following command must be sent to the receiver at every startup:

- "B5 62 06 13 04 00 1F 00 F0 B5 E1 DE".

The **AADET_N** pin then has High = "ANTSTATUS=OPEN", Low = "ANTSTATUS=OK",.

- For more information about how to implement and configure OCD, see *u-blox 7 Receiver Description including Protocol Specification* [4]
- If the antenna supply voltage is not derived from **VCC_RF**, do not exceed the maximum voltage rating of the **AADET_N** pin.
- For more information, see section 3.4.3.1.

3.4.3.4 External active antenna supervisor using customer uP (NEO-7N, MAX-7Q, MAX-7C)

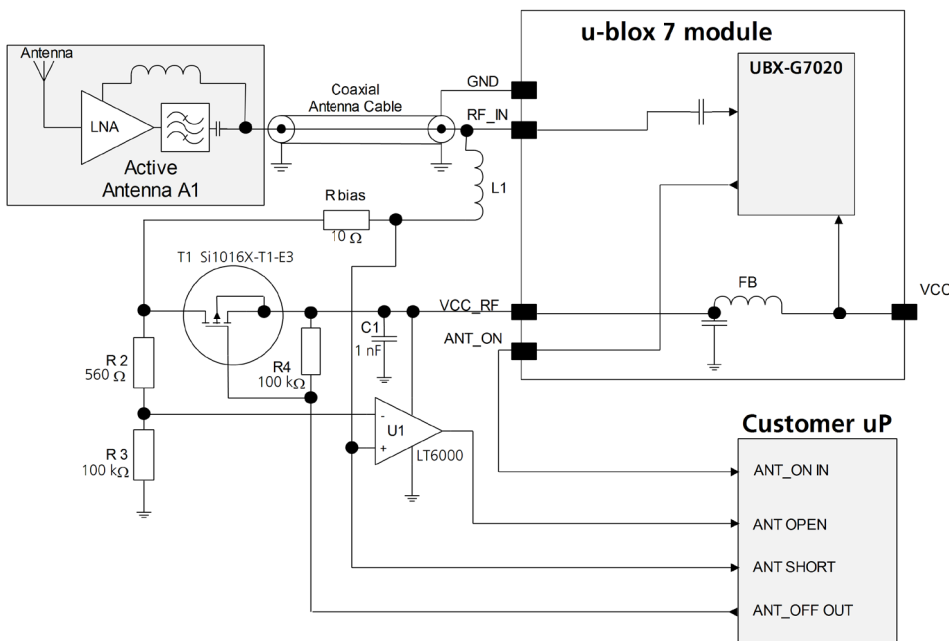

Figure 25: External active antenna supervisor using ANT_ON

$$I = \left(\frac{R2}{R2 + R3} \right) \cdot V_{cc_RF}$$

Equation 2: Calculation of threshold current for open circuit detection

3.4.3.5 External active antenna control (NEO-7N, MAX-7Q, MAX-7C)

The ANT_ON signal can be used to turn on and off an external LNA. This reduces power consumption in Power Save Mode (Backup mode).

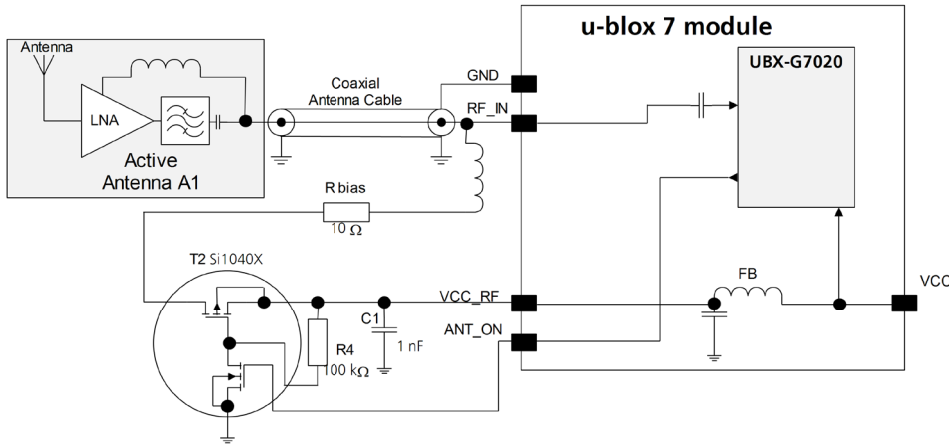

Figure 26: External active antenna control (MAX-7Q / MAX-7C)

3.4.4 Design with GLONASS / GPS active antenna

The Russian GLONASS satellite system is an alternative system to the US-based Global Positioning System (GPS). u-blox 7 modules can receive and process GLONASS signals. GLONASS and GPS satellite signals are not transmitted at the same frequency (as seen in Figure 27). In existing designs that were only intended for GPS reception, the RF path has to be modified (the LNA, filter, and antenna) accordingly to let both signals pass.

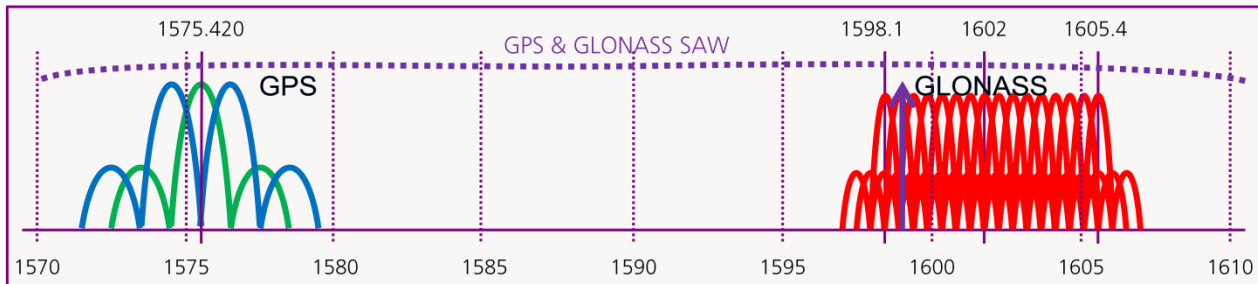

Figure 27: GPS & GLONASS SAW filter

Usually an active GPS antenna includes a GPS band pass filter, which may filter out the GLONASS signal (see Figure 27). For this reason, make sure that the filter in the active antenna is wide enough to let the GPS and GLONASS signals pass. Use a good performance GPS & GLONASS active antenna (for recommended components see section 3.5.1).

In a combined GPS & GLONASS antenna, be sure to tune the antenna for receiving both signals. In addition, any internal filter has a larger bandwidth to provide optimal GPS & GLONASS signal reception.



Use a good performance GPS & GLONASS active antenna (for recommended components see section 3.5.1).

3.4.5 Design with GLONASS / GPS passive antenna

In general, GPS patch antennas only receive GPS signals well. A typical return plot (S11 measurement) shows that the GLONASS signal is highly attenuated. (See Figure 28)

u-blox 7 modules supporting GLONASS have a GPS & GLONASS SAW filter that lets both GPS and GLONASS signals pass. For best performance with passive antenna designs, use an external LNA. (See section 3.4.1.2).

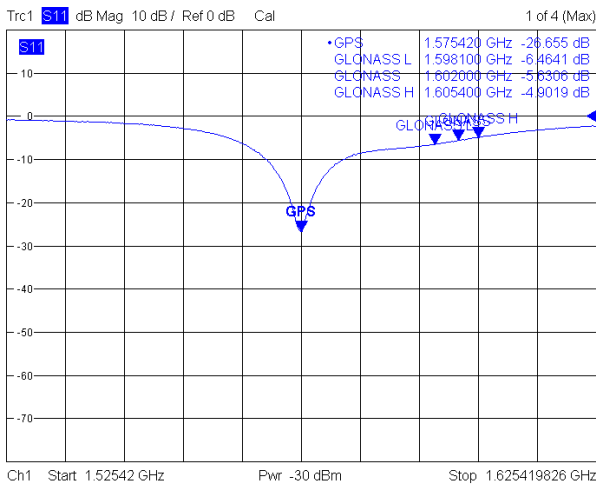

Figure 28: 25*25*4 mm GPS patch antenna on 70*70 mm GND plane

To receive GPS and GLONASS, a special antenna patch (which can receive both GPS and GLONASS) is needed. The return plot (S11 measurement) in Figure 29 below shows the two areas of lower attenuation.

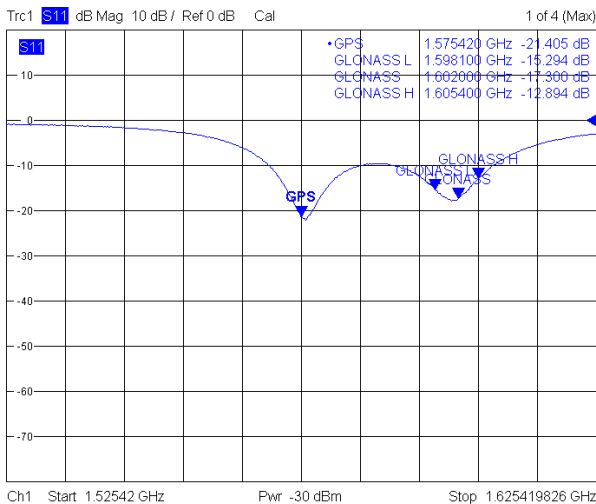

Figure 29: 25*25*4 mm GPS / GLONASS patch antenna on 70*70 mm GND plane

3.5 Recommended parts

u-blox has tested and recommends the parts listed in Table 8. Other untested components may also be used.

	Manufacturer	Part ID	Remarks	Parameters to consider
Diode	ON Semiconductor	ESD9R3.3ST5G	Standoff voltage > 3.3 V	Low Capacitance < 0.5 pF
		ESD9L3.3ST5G	Standoff voltage > 3.3 V	Standoff voltage > voltage for active antenna
		ESD9L5.0ST5G	Standoff voltage > 5 V	Low Inductance
SAW	TDK/ EPCOS	B8401: B39162-B8401-P810	GPS+GLONASS	High attenuation
	TDK/ EPCOS	B3913: B39162B3913U410	GPS+GLONASS	For automotive application
	TDK/ EPCOS	B9850: B39162B9850P810	GPS	Low insertion loss
	TDK/ EPCOS	B8400: B39162B8400P810	GPS	ESD protected and high input power
	muRata	SAFEA1G58KB0F00	GPS+GLONASS	Low insertion loss, only for mobile application
	muRata	SAFEA1G58KA0F00	GPS+GLONASS	High attenuation, only for mobile application
	muRata	SAFFB1G58KA0F0A	GPS+GLONASS	High attenuation, only for mobile application
	muRata	SAFFB1G58KB0F0A	GPS+GLONASS	Low insertion loss, Only for mobile application
	Triquint	B9850	GPS	Compliant to the AEC-Q200 standard
CTS	CER0032A	GPS	Ceramic filter also offers robust ESD protection	
LNA	Avago	ALM-1106	LNA	pHEMT (GaAS)
		ALM-1412	LNA + FBAR Filter	
		ALM-1712	Filter + LNA + FBAR Filter	
		ALM-1912	LNA	Module, for GPS only, also including FBAR filter in front of LNA
		ALM-2412	LNA + FBAR Filter	
		ALM-2712	LNA	Module, for GPS only, FBAR filter-LNA filter FBAR
	MAXIM	MAX2659ELT+	LNA	Low noise figure, up to 10 dBm RF input power
	JRC	NJG1143UA2	LNA	Low noise figure, up to 15 dBm RF input power
	Infineon	BGM1032N16	Filter + LNA	
		BGM781N11	Filter + LNA + Filter	
		BGM1052N16	LNA + Filter	
Triquint	TQM640002	Filter + LNA + Filter		
Inductor	Murata	LQG15HS27NJ02	L, 27 nH	Impedance @ freq GPS > 500 Ω
Capacitor	Murata	GRM1555C1E470JZ01	C, 47 pF	DC-block
Ferrite Bead	Murata	BLM15HD102SN1	FB	High IZI @ fGSM
Feed thru	Murata	NFL18SP157X1A3	Monolithic Type	For data signals, 34 pF load capacitance

Capacitor for Signal		NFA18SL307V1A45	Array Type	For data signals, 4 circuits in 1 package
Feed thru Capacitor	Murata	NFM18PC NFM21P....	0603 2A 0805 4A	$R_s < 0.5 \Omega$
Resistor		$10 \Omega \pm 10\%$, min 0.250 W $560 \Omega \pm 5\%$ $100 \text{ k}\Omega \pm 5\%$	R_{bias} R2 R3, R4	
Op Amp	Linear Technology	LT6000	U1	Rail to Rail
Transistor	Vishay	Si1016X	T1	
Transistor	Vishay	Si1040X	T2	

Table 8: Recommended parts

3.5.1 Recommended GPS & GLONASS active antenna (A1)

Manufacturer	Order No.	Comments
Taoglas (www.taoglas.com)	AA.160.301111	36*36*4 mm, 3 to 5V / 30mA
Taoglas (www.taoglas.com)	AA.161.301111	36*36*3 mm, 1.8 to 5.5V / 10mA at 3V
INPAQ	B3G02G-S3-01-A	2.7 to 3.9 V / 10 mA
Hirschmann	GLONASS 9 M	2.7 to 5.5 V / 13 mA
Amotech (www.amotech.co.kr)	AGA363913-S0-A1	GPS+GLONASS+BeiDou active

Additional antenna Manufacturer:

Allis Communications, 2J, Tallysman Wireless

Table 9: Recommend GPS & GLONASS active antenna (A1)

3.5.2 Recommended GPS & GLONASS passive patch antenna

Manufacturer	Order No.	Comments
Amotech (www.amotech.co.kr)	B35-3556920-2J2	35x35x3 mm GPS+GLONASS
Amotech (www.amotech.co.kr)	A25-4102920-2J3	25x25x4 mm GPS+GLONASS
Amotech (www.amotech.co.kr)	A18-4135920-AMT04	18x18x4 mm GPS+GLONASS

Table 10: Recommend GPS & GLONASS passive patch antenna

3.5.3 Recommended GPS & GLONASS passive chip antenna

Manufacturer	Order No.	Comments
4 INPAQ (www.inpaq.com.tw)	ACM4-5036-A1-CC-S	5 5.2 x 3.7 x 0.7 mm GPS+GLONASS

Table 11: Recommend GPS & GLONASS passive chip antenna

6 Migration to u-blox-7 modules

6.1 Migrating u-blox 6 designs to a u-blox 7 module

Figure 30 below shows a recommended migration path from u-blox 6 designs to use with u-blox 7 modules. u-blox is committed to ensuring that products in the same form factor are backwards compatible over several technology generations. Utmost care has been taken to ensure no negative impact on function or performance and to make u-blox 7 modules as fully compatible as possible with u-blox 6 versions. No limitations of the standard features have resulted. It is highly advisable that customers consider a design review with the u-blox support team to ensure the compatibility of key functionalities.

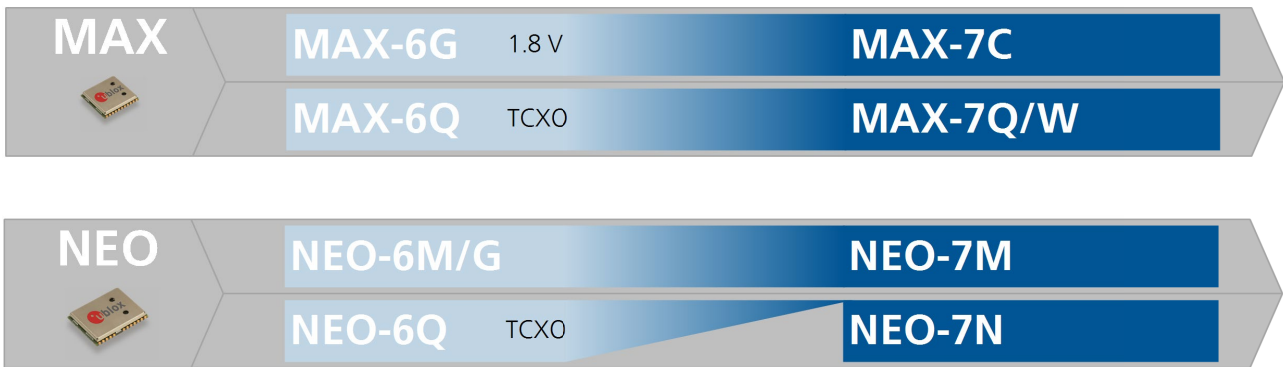

Figure 30: Module migration path

6.2 Hardware migration

6.2.1 Hardware compatibility:

Table 12 provides a summary of important hardware migration issues to note.

	NEO-7	MAX-7
Fully compatible	VCC, RF_IN, GND, USB pins, TxD, RxD, VCC_RF, SDA and SCL	VCC, RF_IN, GND, TxD, RxD, VCC_RF, SDA and SCL
Changes	SPI implementation has changed: With u-blox 6, SPI uses pins 2, 14, 15, 16. With u-blox 7, SPI is available on pins 18, 19, 20, 21 when pin 2 set low. See Table 13	
Not supported	SPI Flash	On-board RTC clock unavailable on MAX-7C, use the "Single Crystal" feature instead.
Limitations	UART/ DDC and SPI share the same pins and are mutually exclusive. No Configuration pins: use of e-fuse possible (See Data Sheet for more information)	ANT_ON voltage level (VCC_IO)

Table 12: Summary of important hardware migration issues

6.2.2 Hardware migration NEO-6 -> NEO-7

Pin	NEO-6		NEO-7		Remarks for Migration
	Pin Name	Typical Assignment	Pin Name	Typical Assignment	
1	RESERVED	Leave open.	RESERVED	Leave open.	No difference
2	SS_N	SPI Slave Select	D_SEL	selects the interface	-> Different functions, compatible only when not using SPI for communication.
3	TIMEPULSE	Time pulse (1PPS)	TIMEPULSE	Time pulse (1PPS)	No difference
4	EXTINT0	External interrupt pin	EXTINT0	External interrupt pin	No difference
5	USB_DM	USB data	USB_DM	USB Data	No difference
6	USB_DP	USB data	USB_DP	USB Data	No difference
7	VDD_USB	USB supply	VDD_USB	USB supply	No difference
8	RESERVED	Pin 8 and 9 must be connected together.	RESET_N	Reset input	If pin 8 is connected to pin 9 on NEO-7N, the device always runs. With NEO-6Q, if Reset input is used, it implements the 3k3 resistor from pin 8 to pin 9. This also works with NEO-7N. If used with NEO-7N, do not populate the pull-up resistor.
9	VCC_RF	Can be used for active antenna or external LNA supply.	VCC_RF	Can be used for active antenna or external LNA supply.	No difference
10	GND	GND	GND	GND	No difference
11	RF_IN	GPS signal input	RF_IN	GPS signal input	No difference
12	GND	GND	GND	GND	No difference
13	GND	GND	GND	GND	No difference
14	MOSI/CFG_COM0	SPI MOSI / Configuration pin. Leave open if not used.	ANT_ON	turn on and off an optional external LNA	ANT_ON (antenna on) can be used to turn on and off an optional external LNA. -> Different functions, no SPI MOSI and configuration pins with NEO-7. If not used as default configuration, it must be set using software command! It is not possible to migrate from NEO-6 to NEO-7N, if NEO-6 pin 14 is connected to GND. In this case, migrate to NEO-7M!
15	MISO/CFG_COM1	SPI MISO / Configuration pin. Leave open if not used.	RESERVED	Leave open.	
16	CFG_GPS0/SCK	Power Mode Configuration pin / SPI Clock. Leave open if not used.	RESERVED	Leave open.	
17	RESERVED	Leave open.	RESERVED	Leave open.	No difference
18	SDA	DDC Data	SDA	DDC Data / SPI CS_N	No difference for DDC. If pin 2 low = SPI chip select.
19	SCL	DDC Clock	SCL	DDC Clock / SPI SCK	No difference for DDC. If pin 2 low = SPI clock.
20	TxD	Serial Port	TxD	Serial Port / SPI MISO	No difference for UART. If pin 2 low = SPI MISO.
21	RxD	Serial Port	RxD	Serial Port / SPI MOSI	No difference for UART. If pin 2 low = SPI MOSI.
22	V_BCKP	Backup supply voltage	V_BCKP	Backup supply voltage	Check current in Data Sheet If on u-blox 6 module this was connected to GND, no problem to do the same in u-blox 7.
23	VCC	Supply voltage NEO-6G: 1.75 – 2.0V NEO-6Q/M/P/V/T: 2.7 – 3.6V	VCC	Supply voltage NEO-7M: 1.65 – 3.6V NEO-7N/P: 2.7 – 3.6V	See Figure 30 for migration path

Pin	NEO-6		NEO-7		Remarks for Migration
	Pin Name	Typical Assignment	Pin Name	Typical Assignment	
24	GND	GND	GND	GND	No difference

Table 13: Pin-out comparison NEO-6 vs. NEO-7

6.2.3 Hardware migration MAX-6 -> MAX-7

Pin	MAX-6		MAX-7		Remarks for Migration
	Pin Name	Typical Assignment	Pin Name	Typical Assignment	
1	GND	GND	GND	GND	No difference
2	TxD	Serial Port	TxD	Serial Port	No difference
3	RxD	Serial Port	RxD	Serial Port	No difference
4	TIMEPULSE	Time pulse (1PPS)	TIMEPULSE	Time pulse (1PPS)	No difference
5	EXTINT0	External Interrupt pin	EXTINT0	External Interrupt pin	No difference
6	V_BCKP	Backup supply voltage	V_BCKP	Backup supply voltage	If on u-blox 6 module this was connected to GND, no problem to do the same in u-blox 7. (MAX-7C: Higher backup current, see 2.5.3.1 Single Crystal)
7	VCC_IO	IO supply voltage Input must be always supplied. Usually connect to VCC pin 8	VCC_IO	IO supply voltage Input must be always supplied. Usually connect to VCC pin 8	No difference
8	VCC	Power supply of module MAX-6G 1.75 – 2.0V MAX-6Q/C: 2.7 – 3.6V	VCC	Power supply of module MAX-7C: 1.65 – 3.6V MAX-7Q: 2.7 – 3.6V	
9	VRESET	connect to pin 8	RESET_N	Reset input	With MAX-6, if Reset input is used, it implements the 3k3 resistor from pin 9 to pin 8. This also works with MAX-7. If used with MAX-7, do not populate the pull-up resistor.
10	GND	GND	GND	GND	No difference
11	RF_IN	Matched RF-Input, DC block inside.	RF_IN	Matched RF-Input, DC block inside.	No difference
12	GND	GND	GND	GND	No difference
13	ANT_ON	Active antenna or ext. LNA control pin in power save mode. ANT_ON pin voltage level: MAX-6 -> VCC_RF (pull-up)	ANT_ON	Active antenna or ext. LNA control pin in power save mode. ANT_ON pin voltage level: MAX-7 -> VCC_IO (push-pull)	On MAX-6, ANT_ON pin voltage level is with respect to VCC_RF, on MAX-7 to VCC_IO (only relevant when VCC_IO does not share the same supply with VCC)
14	VCC_RF	Can be used for active antenna or external LNA supply.	VCC_RF	Can be used for active antenna or external LNA supply.	No difference
15	RESERVED	Leave open.	RESERVED (MAX-7W: V_ANT)	Leave open.	No difference
16	SDA	DDC Data	SDA	DDC Data	No difference
17	SCL	DDC Clock	SCL	DDC Clock	No difference
18	RESERVED	Leave open.	RESERVED	Leave open.	No difference

Table 14: Pin-out comparison MAX-6 vs. MAX-7

6.3 Software migration



For an overall description of the module software operation, refer to the *u-blox 7 Receiver Description including Protocol Specification* [4].

6.3.1 Software compatibility

u-blox 7 modules introduce a new firmware: Version 1.00. When migrating, customers should ensure that commands used originally with u-blox 6 products are supported by the new firmware version. For information about known limitations that could affect migration, see the *u-blox 7 Firmware Version 1.0 Release Note* [5].

Table 15 provides a summary of important software migration issues to note.

Changes	<p>The configuration of the TX Ready feature has changed between MAX-6 and MAX-7 modules and is only recognized from LEON FW 07.70 and LISA-U2 01S onwards. The MAX-6 TxD pin is mapped to PIO#5 while the MAX-7 TxD pin is mapped to PIO#6. When communicating with u-blox cellular modules, this change of pins is not recognized by LEON FW7.60.02 and previous versions.</p> <p>u-blox 6: 15 s leap second by default (FW 6.02 and FW7.0x)</p> <p>u-blox 7: 16 s leap second by default</p>
---------	---

Table 15: Summary of important software migration issues



Low power modes are supported by the Power Save Mode of FW 1.0 or ROM 1.0. For migration, consult the *u-blox 7 Firmware Version 1.0 Release Note* [5] and the *u-blox 7 Receiver Description Including Protocol Specification* [4].

6.3.2 Messages no longer supported

u-blox 6	u-blox 7	Remarks
UBX-CFG-TP	UBX-CFG-TP5	This has been replaced with the more versatile CFG-TP5, which allows for two separate time pulses and more parameters to set their function.
UBX-CFG-PM	UBX-CFG-PM2	This has been replaced with CFG-PM2, which allows for a more extended Power management configuration.
UBX-CFG-FXN	UBX-CFG-PM2	This has been replaced by CFG-PM2.
UBX-CFG-TMODE	UBX-CGF-TMODE2	This has been replaced by CGF-TMODE2.
NMEA-PUBX05	-	Not available in this firmware.
NMEA-PUBX06	-	Not available in this firmware.

Table 16: Main differences between u-blox 6 and u-blox 7 software for migration

7 Product handling

7.1 Packaging, shipping, storage and moisture preconditioning

For information pertaining to reels and tapes, Moisture Sensitivity levels (MSD), shipment and storage information, as well as drying for preconditioning see the specific u-blox 7 GNSS module data sheet.

7.1.1 Population of Modules



When populating our modules make sure that the pick and place machine is aligned to the copper pins of the module and not on the module edge.

7.2 Soldering

7.2.1 Soldering paste

Use of "No Clean" soldering paste is strongly recommended, as it does not require cleaning after the soldering process has taken place. The paste listed in the example below meets these criteria.

Soldering Paste: OM338 SAC405 / Nr.143714 (Cookson Electronics)

Alloy specification: Sn 95.5/ Ag 4/ Cu 0.5 (95.5% Tin/ 4% Silver/ 0.5% Copper)

Melting Temperature: 217 °C

Stencil Thickness: 150µm The final choice of the soldering paste depends on the approved manufacturing procedures.

The paste-mask geometry for applying soldering paste should meet the recommendations.



The quality of the solder joints on the connectors ('half vias') should meet the appropriate IPC specification.

7.2.2 Reflow soldering

A convection type-soldering oven is strongly recommended over the infrared type radiation oven. Convection heated ovens allow precise control of the temperature and all parts will be heated up evenly, regardless of material properties, thickness of components and surface color.

Consider the "IPC-7530 Guidelines for temperature profiling for mass soldering (reflow and wave) processes, published 2001. "

Preheat phase

Initial heating of component leads and balls. Residual humidity will be dried out. Please note that this preheat phase will not replace prior baking procedures.

- Temperature rise rate: max. 3 °C/s If the temperature rise is too rapid in the preheat phase it may cause excessive slumping.
- Time: 60 - 120 s If the preheat is insufficient, rather large solder balls tend to be generated. Conversely, if performed excessively, fine balls and large balls will be generated in clusters.
- End Temperature: 150 - 200 °C If the temperature is too low, non-melting tends to be caused in areas containing large heat capacity.

Heating/ Reflow phase

The temperature rises above the liquidus temperature of 217°C. Avoid a sudden rise in temperature as the slump of the paste could become worse.

- Limit time above 217 °C liquidus temperature: 40 - 60 s
- Peak reflow temperature: 245 °C

Cooling phase

A controlled cooling avoids negative metallurgical effects (solder becomes more brittle) of the solder and possible mechanical tensions in the products. Controlled cooling helps to achieve bright solder fillets with a good shape and low contact angle.

- Temperature fall rate: max 4 °C/s



To avoid falling off, the u-blox 7 GNSS module should be placed on the topside of the motherboard during soldering.

The final soldering temperature chosen at the factory depends on additional external factors like choice of soldering paste, size, thickness and properties of the base board, etc. Exceeding the maximum soldering temperature in the recommended soldering profile may permanently damage the module.

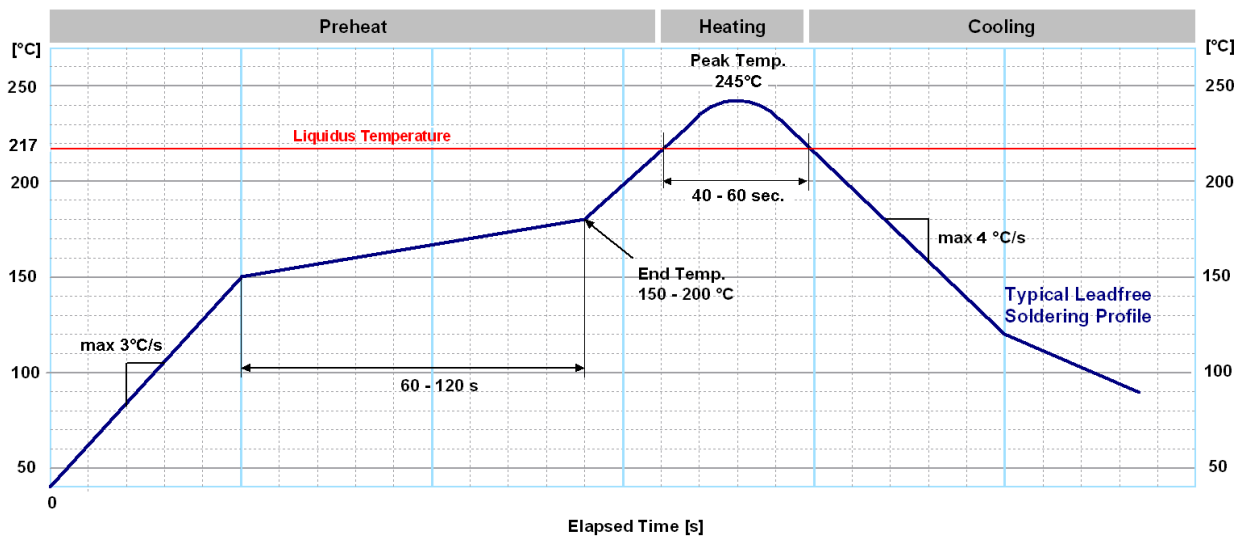

Figure 31: Recommended soldering profile



u-blox 7 modules **must not** be soldered with a damp heat process.

7.2.3 Optical inspection

After soldering the u-blox 7 module, consider an optical inspection step to check whether:

- The module is properly aligned and centered over the pads
- All pads are properly soldered
- No excess solder has created contacts to neighboring pads, or possibly to pad stacks and vias nearby

7.2.4 Cleaning

In general, cleaning the populated modules is strongly discouraged. Residues underneath the modules cannot be easily removed with a washing process.

- Cleaning with water will lead to capillary effects where water is absorbed in the gap between the baseboard and the module. The combination of residues of soldering flux and encapsulated water leads to short circuits or resistor-like interconnections between neighboring pads.

- Cleaning with alcohol or other organic solvents can result in soldering flux residues flooding into the two housings, areas that are not accessible for post-wash inspections. The solvent will also damage the sticker and the ink-jet printed text.
- Ultrasonic cleaning will permanently damage the module, in particular the quartz oscillators.

The best approach is to use a "no clean" soldering paste and eliminate the cleaning step after the soldering.

7.2.5 Repeated reflow soldering

Only single reflow soldering processes are recommended for boards populated with u-blox 7 modules. u-blox 7 modules should not be submitted to two reflow cycles on a board populated with components on both sides in order to avoid upside down orientation during the second reflow cycle. In this case, the module should always be placed on that side of the board, which is submitted into the last reflow cycle. The reason for this (besides others) is the risk of the module falling off due to the significantly higher weight in relation to other components.

Two reflow cycles can be considered by excluding the above described upside down scenario and taking into account the rework conditions described in Section 5.2.8.



Repeated reflow soldering processes and soldering the module upside down are not recommended.

7.2.6 Wave soldering

Base boards with combined through-hole technology (THT) components and surface-mount technology (SMT) devices require wave soldering to solder the THT components. Only a single wave soldering process is encouraged for boards populated with u-blox 7 modules.

7.2.7 Hand soldering

Hand soldering is allowed. Use a soldering iron temperature setting equivalent to 350 °C. Place the module precisely on the pads. Start with a cross-diagonal fixture soldering (e.g. pins 1 and 15), and then continue from left to right.

7.2.8 Rework

The u-blox 7 module can be unsoldered from the baseboard using a hot air gun. When using a hot air gun for unsoldering the module, max one reflow cycle is allowed. In general, we do not recommend using a hot air gun because this is an uncontrolled process and might damage the module.

 **Attention: use of a hot air gun can lead to overheating and severely damage the module. Always avoid overheating the module.**

After the module is removed, clean the pads before placing and hand soldering a new module.

 **Never attempt a rework on the module itself, e.g. replacing individual components. Such actions immediately terminate the warranty.**

In addition to the two reflow cycles, manual rework on particular pins by using a soldering iron is allowed. Manual rework steps on the module can be done several times.

7.2.9 Conformal coating

Certain applications employ a conformal coating of the PCB using HumiSeal® or other related coating products. These materials affect the HF properties of the GNSS module and it is important to prevent them from flowing into the module. The RF shields do not provide 100% protection for the module from coating liquids with low viscosity; therefore, care is required in applying the coating.



Conformal Coating of the module will void the warranty.

7.2.10 Casting

If casting is required, use viscose or another type of silicon pottant. The OEM is strongly advised to qualify such processes in combination with the u-blox 7 module before implementing this in the production.



Casting will void the warranty.

7.2.11 Grounding metal covers

Attempts to improve grounding by soldering ground cables, wick or other forms of metal strips directly onto the EMI covers is done at the customer's own risk. The numerous ground pins should be sufficient to provide optimum immunity to interferences and noise.



u-blox makes no warranty for damages to the u-blox 7 module caused by soldering metal cables or any other forms of metal strips directly onto the EMI covers.

7.2.12 Use of ultrasonic processes

Some components on the u-blox 7 module are sensitive to Ultrasonic Waves. Use of any Ultrasonic Processes (cleaning, welding etc.) may cause damage to the GNSS Receiver.



u-blox offers no warranty against damages to the u-blox 7 module caused by any Ultrasonic Processes.

7.3 EOS/ESD/EMI precautions

When integrating GNSS positioning modules into cellular systems, careful consideration must be given to electromagnetic and voltage susceptibility issues. Cellular systems include components that can produce Electrical Overstress (EOS) and Electro-Magnetic Interference (EMI). CMOS devices are more sensitive to such influences because their failure mechanism is defined by the applied voltage, whereas bipolar semiconductors are more susceptible to thermal overstress. The following design guidelines are provided to help in designing robust yet cost effective solutions.



To avoid overstress damage during production or in the field it is essential to observe strict EOS/ESD/EMI handling and protection measures.

To prevent overstress damage at the RF_IN of your receiver, never exceed the maximum input power (see Data Sheet).

7.3.1 Electrostatic discharge (ESD)

Electrostatic discharge (ESD) is the sudden and momentary electric current that flows between two objects at different electrical potentials caused by direct contact or induced by an electrostatic field. The term is usually used in the electronics and other industries to describe momentary unwanted currents that may cause damage to electronic equipment.



7.3.2 ESD handling precautions

ESD prevention is based on establishing an Electrostatic Protective Area (EPA). The EPA can be a small working station or a large manufacturing area. The main principle of an EPA is that there are no highly charging materials near ESD sensitive electronics, all conductive materials are grounded, workers are grounded, and charge build-up on ESD sensitive electronics is prevented. International standards are used to define typical EPA and can be obtained for example from International Electrotechnical Commission (IEC) or American National Standards Institute (ANSI).

GNSS positioning modules are sensitive to ESD and require special precautions when handling. Particular care must be exercised when handling patch antennas, due to the risk of electrostatic charges. In addition to

standard ESD safety practices, the following measures should be taken into account whenever handling the receiver.

- Unless there is a galvanic coupling between the local GND (i.e. the work table) and the PCB GND, then the first point of contact when handling the PCB must always be between the local GND and PCB GND.
- Before mounting an antenna patch, connect ground of the device
- When handling the RF pin, do not come into contact with any charged capacitors and be careful when contacting materials that can develop charges (e.g. patch antenna ~10 pF, coax cable ~50 - 80 pF/m, soldering iron, ...)
- To prevent electrostatic discharge through the RF input, do not touch any exposed antenna area. If there is any risk that such exposed antenna area is touched in non ESD protected work area, implement proper ESD protection measures in the design.
- When soldering RF connectors and patch antennas to the receiver's RF pin, make sure to use an ESD safe soldering iron (tip).



Failure to observe these precautions can result in severe damage to the GNSS module!

7.3.3 ESD protection measures



GNSS positioning modules are sensitive to Electrostatic Discharge (ESD). Special precautions are required when handling.



For more robust designs, employ additional ESD protection measures. Using an LNA with appropriate ESD rating can provide enhanced GNSS performance with passive antennas and increases ESD protection.

Most defects caused by ESD can be prevented by following strict ESD protection rules for production and handling. When implementing passive antenna patches or external antenna connection points, then additional ESD measures as shown in Figure 32 can also avoid failures in the field.

Small passive antennas (<2 dBic and performance critical)	Passive antennas (>2 dBic or performance sufficient)	Active antennas
<p>A</p>  <p>LNA with appropriate ESD rating</p>	<p>B</p> 	<p>C</p> 

Figure 32: ESD Precautions



Protection measure A is preferred because it offers the best GNSS performance and best level of ESD protection.

7.3.4 Electrical Overstress (EOS)

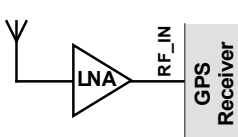
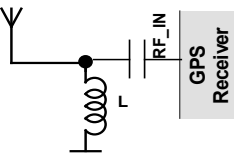
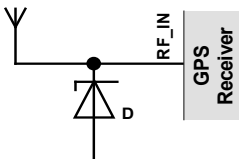
Electrical Overstress (EOS) usually describes situations when the maximum input power exceeds the maximum specified ratings. EOS failure can happen if RF emitters are close to a GNSS receiver or its antenna. EOS causes damage to the chip structures. If the RF_IN is damaged by EOS, it is hard to determine whether the chip structures have been damaged by ESD or EOS.

7.3.5 EOS protection measures



For designs with GNSS positioning modules and cellular (e.g. GSM/GPRS) transceivers in close proximity, ensure sufficient isolation between the cellular and GNSS antennas. If cellular power output causes the specified maximum power input at the GNSS RF_IN to be exceeded, employ EOS protection measures to prevent overstress damage.

For robustness, EOS protection measures, as shown in the examples in Figure 33, are recommended for designs combining cellular communication transceivers (e.g. GSM, GPRS) and GNSS receivers in the same design or in close proximity.

Small passive antennas (<2 dBic and performance critical)	Passive antennas (>2 dBic or performance sufficient)	Active antennas (without internal filter which need the module antenna supervisor circuits)
<p>D</p>  <p>LNA with appropriate ESD rating and maximum input power</p>	<p>E</p>  <p>GPS Band pass Filter: SAW or Ceramic with low insertion loss and appropriate ESD rating</p>	<p>F</p> 

Figure 33: EOS and ESD Precautions

7.3.6 Electromagnetic interference (EMI)

Electromagnetic interference (EMI) is the addition or coupling of energy originating from any RF emitting device. This can cause a spontaneous reset of the GNSS receiver or result in unstable performance. Any unshielded line or segment (>3mm) connected to the GNSS receiver can effectively act as antenna and lead to EMI disturbances or damage.

The following elements are critical regarding EMI:

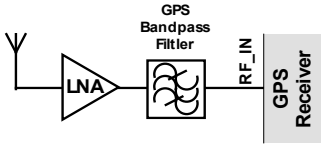
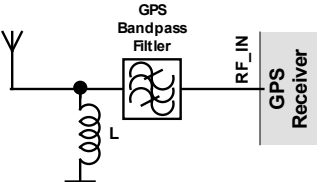
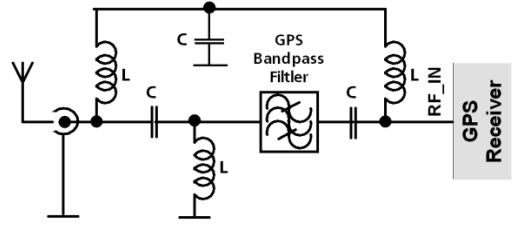
- Unshielded connectors (e.g. pin rows etc.)
- Weakly shielded lines on PCB (e.g. on top or bottom layer and especially at the border of a PCB)
- Weak GND concept (e.g. small and/or long ground line connections)

EMI protection measures are recommended when RF emitting devices are near the GNSS receiver. To minimize the effect of EMI a robust grounding concept is essential. To achieve electromagnetic robustness follow the standard EMI suppression techniques.

<http://www.murata.com/products/emc/knowhow/index.html>

<http://www.murata.com/products/emc/knowhow/pdf/4to5e.pdf>

Improved EMI protection can be achieved by inserting a resistor (e.g. $R > 20 \Omega$) or better yet a ferrite bead (BLM15HD102SN1) or an inductor (LQG15HS47NJ02) into any unshielded PCB lines connected to the GNSS receiver. Place the resistor as close as possible to the GNSS receiver pin.

Example of EMI protection measures on the RX/TX line using a ferrite bead:

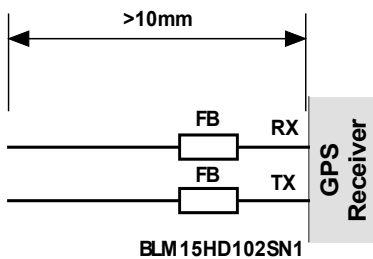

Figure 34: EMI Precautions

VCC can be protected using a feed thru capacitor. For electromagnetic compatibility (EMC) of the RF_IN pin, refer to section 5.3.5

Intended use



In order to mitigate any performance degradation of a radio equipment under EMC disturbance, system integration shall adopt appropriate EMC design practice and not contain cables over three meters on signal and supply ports.

7.3.7 Applications with cellular modules

GSM uses power levels up to 2 W (+33 dBm). Consult the Data Sheet for the absolute maximum power input at the GNSS receiver.

7.3.7.1 Isolation between GPS and GSM antenna

In a handheld type design, an isolation of approximately 20 dB can be reached with careful placement of the antennas. If such isolation cannot be achieved, e.g. in the case of an integrated GSM/GPS antenna, an additional input filter is needed on the GPS side to block the high energy emitted by the GSM transmitter. Examples of these kinds of filters would be the SAW Filters from Epcos (B9444 or B7839) or Murata.

7.3.7.2 Increasing jamming immunity

Jamming signals come from in-band and out-band frequency sources.

7.3.7.3 In-band jamming

With in-band jamming the signal frequency is very close to the GPS frequency of 1575 MHz (see Figure 35). Such jamming signals are typically caused by harmonics from displays, micro-controller, bus systems, etc.

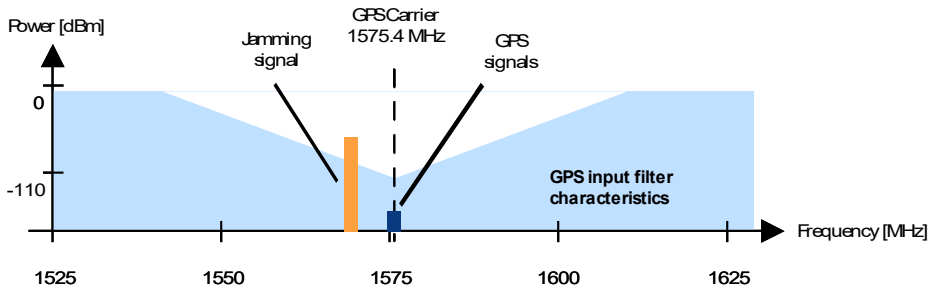

Figure 35: In-band jamming signals

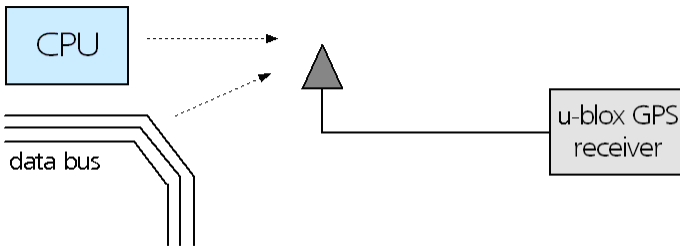

Figure 36: In-band jamming sources

Measures against in-band jamming include:

- Maintaining a good grounding concept in the design
- Shielding
- Layout optimization
- Filtering
- Placement of the GPS antenna
- Adding a CDMA, GSM, WCDMA band pass filter before handset antenna

7.3.7.4 Out-band jamming

Out-band jamming is caused by signal frequencies that are different from the GPS carrier (see Figure 37). The main sources are wireless communication systems such as GSM, CDMA, WCDMA, Wi-Fi, BT, etc.

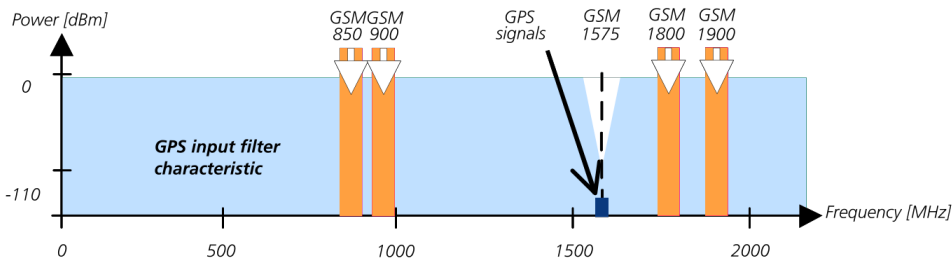

Figure 37: Out-band jamming signals

Measures against out-band jamming include maintaining a good grounding concept in the design and adding a SAW or band pass ceramic filter (as recommend in *Section 5.3.5*) into the antenna input line to the GNSS receiver (see Figure 38).

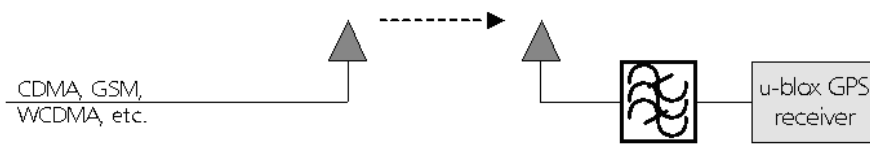

Figure 38: Measures against in-band jamming



For design-in recommendations in combination with cellular operation, see A.2



See the *GPS Implementation and Aiding Features in u-blox wireless modules* [9]

8 Product testing

8.1 u-blox in-series production test

u-blox focuses on high quality for its products. To achieve a high standard it is our philosophy to supply fully tested units. Therefore, at the end of the production process, every unit is tested. Defective units are analyzed in detail to improve the production quality.

This is achieved with automatic test equipment, which delivers a detailed test report for each unit. The following measurements are done:

- Digital self-test (Software Download, verification of FLASH firmware, etc.)
- Measurement of voltages and currents
- Measurement of RF characteristics (e.g. C/No)
- Traceability down to component level
- X-Ray and Automated Optical Inspection (AOI)
- Ongoing Reliability Tests

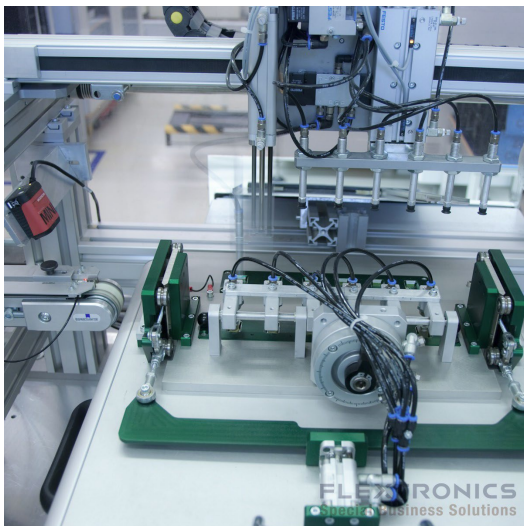

Figure 39: Automatic Test Equipment for Module Tests



Figure 40: X-Ray Inspection

8.2 Test parameters for OEM manufacturer

Because of the testing done by u-blox (with 100% coverage), it is obvious that an OEM manufacturer does not need to repeat firmware tests or measurements of the GNSS parameters/characteristics (e.g. TTFF) in their production test.

An OEM manufacturer should focus on:

- Overall sensitivity of the device (including antenna, if applicable)
- Communication to a host controller

8.3 System sensitivity test

The best way to test the sensitivity of a GNSS device is with the use of a 1-channel GPS simulator. It assures reliable and constant signals at every measurement.



Figure 41: 1-channel GPS simulator

u-blox recommends the following Single-Channel GPS Simulators:

- Spirent GSS6100 (GPS)
 - Spirent GSS6300 (GPS/GLONASS)
- Spirent Communications Positioning Technology, www.spirent.com

8.3.1 Guidelines for sensitivity tests

1. Connect a 1-channel GPS simulator to the OEM product
2. Choose the power level in a way that the "Golden Device" would report a C/No ratio of 38-40 dBHz
3. Power up the DUT (Device Under Test) and allow enough time for the acquisition
4. Read the C/No value from the NMEA GSV or the UBX-NAV-SVININFO message (e.g. with u-center)
5. Compare the results to a "Golden Device" or a u-blox 7 Evaluation Kit.

8.3.2 'Go/No go' tests for integrated devices

The best test is to bring the device to an outdoor position **with excellent sky view** (HDOP < 3.0). Let the receiver acquire satellites and compare the signal strength with a "Golden Device".



As the electro-magnetic field of a redistribution antenna is not homogenous, indoor tests are in most cases not reliable. These kind of tests may be useful as a 'go/no go' test but not for sensitivity measurements.

A Appendix

A.1 Abbreviations

Abbreviation	Definition
ANSI	American National Standards Institute
CDMA	Code Division Multiple Access
EMC	Electromagnetic compatibility
EMI	Electromagnetic interference
EOS	Electrical Overstress
EPA	Electrostatic Protective Area
ESD	Electrostatic discharge
GLONASS	Russian satellite system
GND	Ground
GNSS	Global Navigation Satellite System
GPS	Global Positioning System
GSM	Global System for Mobile Communications
IEC	International Electrotechnical Commission
PCB	Printed circuit board
QZSS	Quasi-Zenith Satellite System

Table 17: Explanation of abbreviations used

A.2 Design-in recommendations in combination with cellular operation

Product		Receiver Chain					Cellular and GNSS Simultaneous operation				
Family	Variant	Antenna	SAW LNA	SAW	On-chip LNA	SAW	Passive GNSS Antenna		Active GNSS Antenna		
							2G cellular	3G/4G cellular	2G/3G/4G cellular	2G/3G/4G cellular	
MAX-6	Any									✓	✓
NEO-6	Any									✓	✓
LEA-6	Any									✓	✓
EVA-7	M				•		✓			✓	✓
MAX-7	C				•		✓			✓	✓
	W				•		✓			✓	✓
	Q				•		✓			✓	✓
NEO-7	N		•		•		✓	✓		✓	✓
	M				•		✓			✓	✓
	P			•	•		✓	✓		✓	✓
PAM-7	Q	•	•	•	•		✓	✓		✓	✓

Table 18: Combinations of u-blox GNSS modules with different cellular technologies (2G/3G/4G).



See the *GPS Implementation and Aiding Features in u-blox wireless modules* [9]

Related documents

- [1] NEO-7 Data Sheet, GPS.G7-HW-11004
- [2] MAX-7 Data Sheet, GPS.G7-HW-12012
- [3] u-blox 7 Receiver Description including Protocol Specification, GPS.G7-SW-12001
- [4] u-blox 7 Firmware Version 1.0 Release Note, GPS.G7-SW-12003
- [5] GPS Antenna Application Note, GPS-X-08014
- [6] UBX-G7020 Data Sheet, GPS.G7-HW-10002
- [7] GPS Compendium, GPS-X-02007
- [8] I²C-bus specification, Rev. 5, Oct 2012, http://www.nxp.com/documents/other/UM10204_v5.pdf
- [9] GPS Implementation and Aiding Features in u-blox cellular modules, GSM.G1-CS-09007



For regular updates to u-blox documentation and to receive product change notifications, please register on our homepage (<http://www.u-blox.com>).

Revision history

Revision	Date	Name	Status / Comments
-	04-Sep-2012	jfur	Initial draft
1	20-Dec-2012	jfur	MAX-7W added, Revision Chapter 3.4 Antenna supervision; MAX-7C: Higher backup current, new Figure 42 and 43; DC-bloc removed from Figure 21 and Figure 22
2	11-Feb-2013	jfur	NEO-7P added, Electrical Programmable Fuse (eFuse) added
3	22-Apr-2013	jfur	Stencil thickness 150 um (Figure 9, 12, 13); Table 15: (MAX-7W: V_ANT) added; Added section 5.1.1 Population of Modules
4	17-Jun-2013	jfur	ANT_ON description; Recommended GPS & GLONASS active antenna updated Last revision with old document number GPS.G7-HW-11006
R06	30-Sep-2013	jfur	Antenna open circuit detection (OCD) for MAX-7W in section 3.4.3.3
R07	20-Jan-2014	jfur	Document status changed to Early Production Information. LEA-7N removed; Figure 18, Figure 26 and Figure 30 updated.
R08	20-May-2014	jfur	Production Information; Appendix A.2 added: Design-in recommendations in combination with cellular operation
R09	27-Sep-2017	msul	Added information on RED DoC in European Union regulatory compliance (page 2), added Intended use statement in section 7.3.6 Electromagnetic interference (EMI), updated legal statement in cover page and added Documentation feedback e-mail address in contacts page.
R10	02-Jun-2021	imar	Updated PCN reference for MAX-7Q in page 2.

Contact

For complete contact information, visit us at www.u-blox.com

u-blox Offices

North, Central and South America

u-blox America, Inc.

Phone: +1 703 483 3180
Email: info_us@u-blox.com

Regional Office West Coast:

Phone: +1 408 573 3640
Email: info_us@u-blox.com

Technical Support:

Phone: +1 703 483 3185
Email: support@u-blox.com

Headquarters

Europe, Middle East, Africa

u-blox AG

Phone: +41 44 722 74 44
Email: info@u-blox.com
Support: support@u-blox.com

Asia, Australia, Pacific

u-blox Singapore Pte. Ltd.

Phone: +65 6734 3811
Email: info_ap@u-blox.com
Support: support_ap@u-blox.com

Regional Office Australia:

Phone: +61 3 9566 7255
Email: info_au@u-blox.com
Support: support_ap@u-blox.com

Regional Office China (Beijing):

Phone: +86 10 68 133 545
Email: info_cn@u-blox.com
Support: support_cn@u-blox.com

Regional Office China (Chongqing):

Phone: +86 23 6815 1588
Email: info_cn@u-blox.com
Support: support_cn@u-blox.com

Regional Office China (Shanghai):

Phone: +86 21 6090 4832
Email: info_cn@u-blox.com
Support: support_cn@u-blox.com

Regional Office China (Shenzhen):

Phone: +86 755 8627 1083
Email: info_cn@u-blox.com
Support: support_cn@u-blox.com

Regional Office India:

Phone: +91 80 405 092 00
Email: info_in@u-blox.com Support: support_in@u-blox.com

Regional Office Japan (Osaka):

Phone: +81 6 6941 3660
Email: info_jp@u-blox.com
Support: support_jp@u-blox.com

Regional Office Japan (Tokyo):

Phone: +81 3 5775 3850
Email: info_jp@u-blox.com
Support: support_jp@u-blox.com

Regional Office Korea:

Phone: +82 2 542 0861
Email: info_kr@u-blox.com
Support: support_kr@u-blox.com

Regional Office Taiwan:

Phone: +886 2 2657 1090
Email: info_tw@u-blox.com
Support: support_tw@u-blox.com