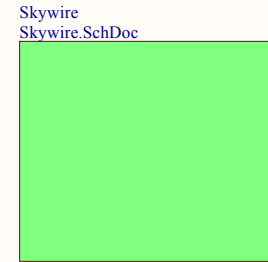

TABLE OF CONTENTS	
PAGE	DESCRIPTION
1	TITLE PAGE
2	Skywire
3	mPCIe Connector

TITLE PAGE



© NimbeLink Corp. 2016. All rights reserved.

NimbeLink Corp. provides this documentation in support of its products for the internal use of its current and prospective customers. The publication of this document does not create any other right or license in any party to use any content contained in or referred to in this document and any modification or redistribution of this document is not permitted.

While efforts are made to ensure accuracy, typographical and other errors may exist in this document. NimbeLink reserves the right to modify or discontinue its products and to modify this and any other product documentation at any time.

All NimbeLink products are sold subject to its published Terms and Conditions, subject to any separate terms agreed with its customers. No warranty of any type is extended by publication of this documentation, including, but not limited to, implied warranties of merchantability, fitness for a particular purpose and non-infringement.

Skywire and NimbeLink are trademarks of NimbeLink Corp. All other trademarks appearing in the document are the property of their respective owners.

IMPORTANT NOTES ABOUT THIS SCHEMATIC

DESIGN NOTE: Example text for the design note to show the note inside the colored box.

1) DESIGN NOTES in grey are information notes.

DESIGN NOTE: Example text for the design note to show the note inside the colored box.

2) DESIGN NOTES in red are critical, and must be understood and followed.

✘ 3) A red X indicates suppression of error checking on a pin/net. Commonly suppressed errors include: single-pin net, no driving source, etc.

4) All unique components in this schematic should have a manufacturer's part number displayed; exceptions to this rule are commodity passives such as resistors and capacitors.

5) Finally, population vs. non-population intent is indicated by adding "NP" next to the part. All parts with "NP" next to the part are intended to be unplaced during assembly.

© NimbeLink Corp. 2016. All rights reserved.

		www.nimbelink.com MINNEAPOLIS	
Title: TITLE			
Project: mPCIe Skywire Adaptor	Size: C	Sheet 1	of 4
Number: 20027	Rev: 3	Modified: 5/17/2016	1:52:45 PM
Prepared for: mPCIe Schematic			CONFIDENTIAL

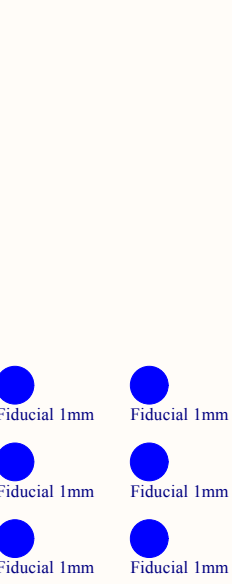

Shutdown is used by the end user device to restart the modem in the event the modem stops operating. Do not use it to power cycle the xE910 device. Reset_nIN is internally pulled up.

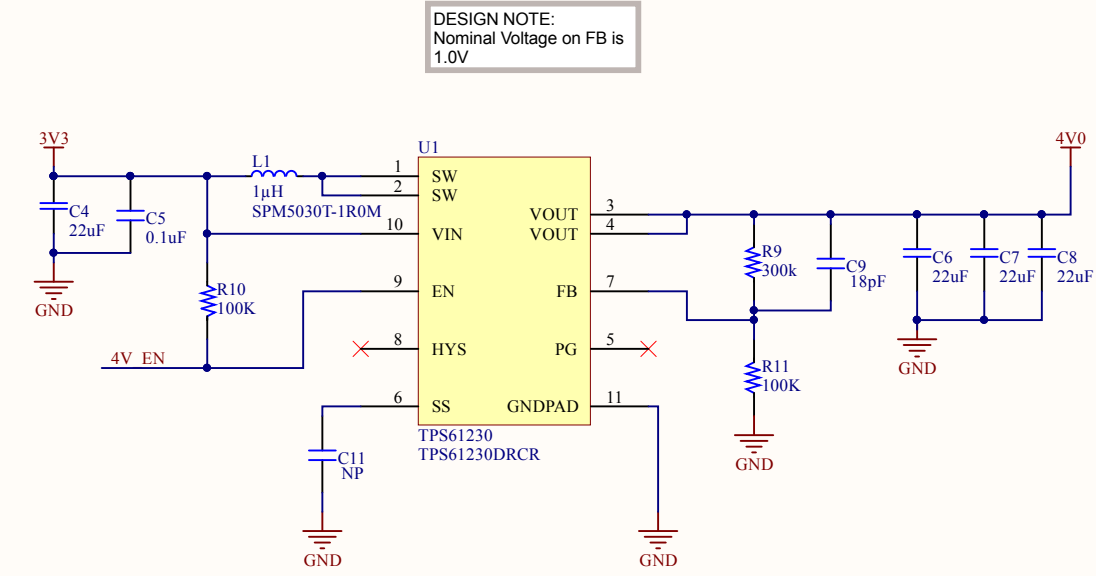
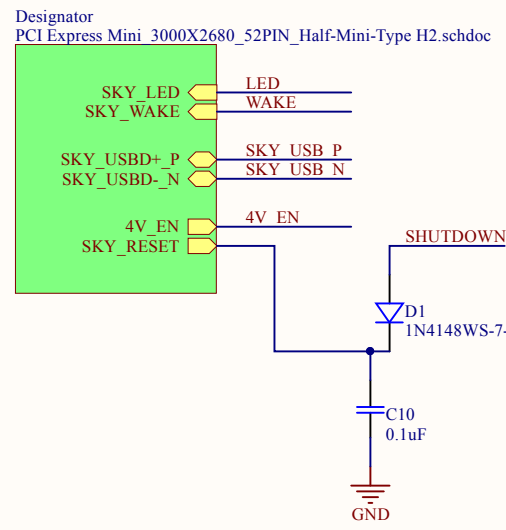
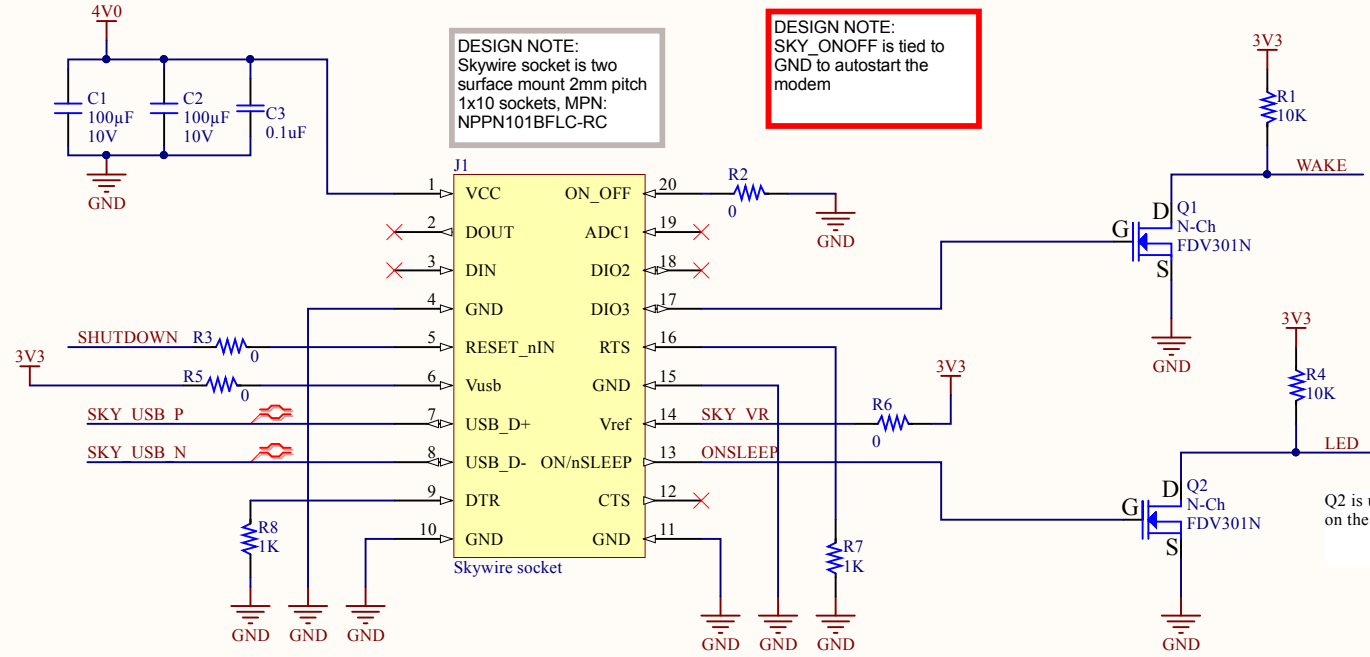

© NimbeLink Corp. 2016. All rights reserved.

NimbeLink		www.nimbelink.com	
MINNEAPOLIS			
Title: SKYWIRE			
Project: mPCIe Skywire Adaptor	Size: C	Sheet 2	of 4
Number: 20027	Rev: 3	Modified: 5/17/2016	1:52:45 PM
Prepared for: mPCIe Schematic		CONFIDENTIAL	

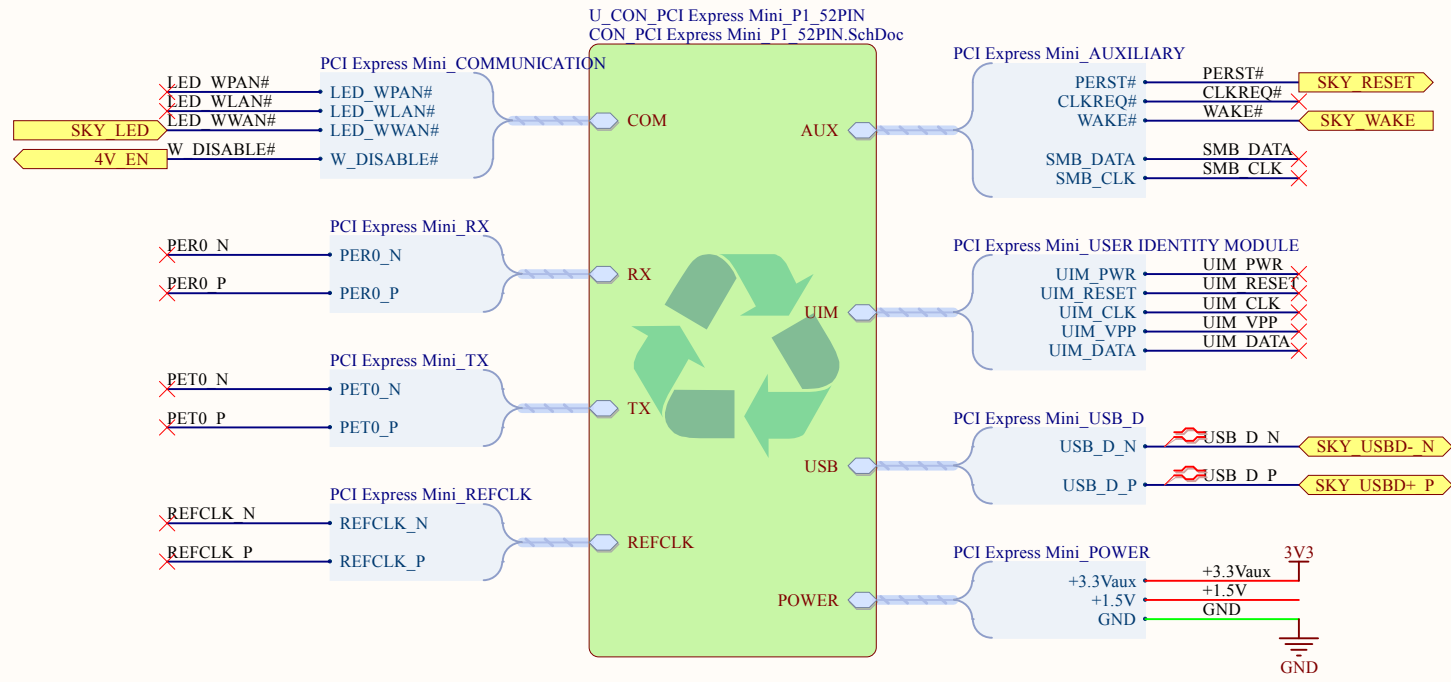

- Nominal values used, all dimensions in mm
- Pins 2 and 52 (+3.3V), Pin 6 and 48 (+1.5V), each group assigned to same signals on assumption (see PCI_Express_Mini_CEM_12_26Oct07_ncb.pdf, page 50 and 51)
- Room for component keep-out on top layer is approximated about corner arcs.
- Component height rule derived from PCI_Express_Mini_CEM_12_26Oct07_ncb.pdf, Page 18
- Stackup is not specified in PCI_Express_Mini_CEM_12_26Oct07_ncb.pdf nor implemented in this template.

Sheet Title PCI Express H2 Top Sheet		Nimbelink ProjectAddress I 3131 Fernbrook Lane N, Suite 105 Plymouth, MN 55447	
Project Title Skywire mPCIe half card			
Size: A4	Item:	Revision:	
Date: 5/17/2016	Time: 1:52:45 PM	Sheet 3 of 4	
File: PCI Express Mini_3000X2680_52PIN_Half-Mini-Type H2.schdoc			

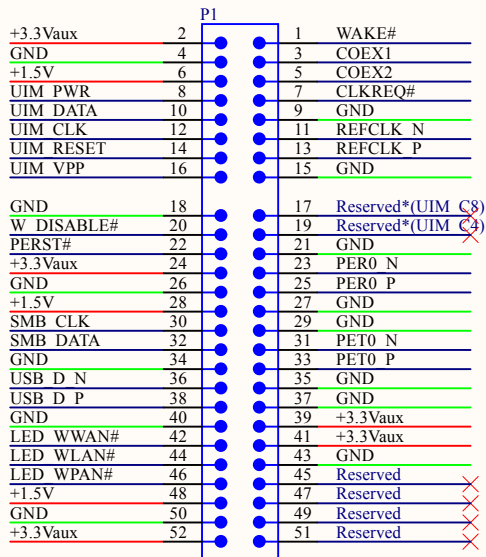

PCIeMini-CN-2S-M-R52

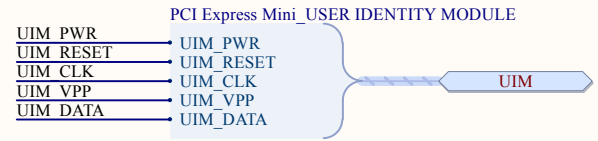
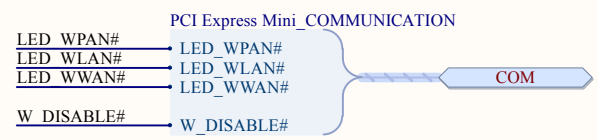

Sheet Title PCI Express Mini 52Pin		Nimbelink ProjectAddress I 3131 Fernbrook Lane N, Suite 106 Plymouth, MN 55447	
Project Title Skywire mPCIe half card			
Size: A4	Item:	Revision:	
Date: 5/17/2016	Time: 1:52:45 PM	Sheet * of *	
File: CON_PCI Express Mini_P1_52PIN.SchDoc			